

namco[®]

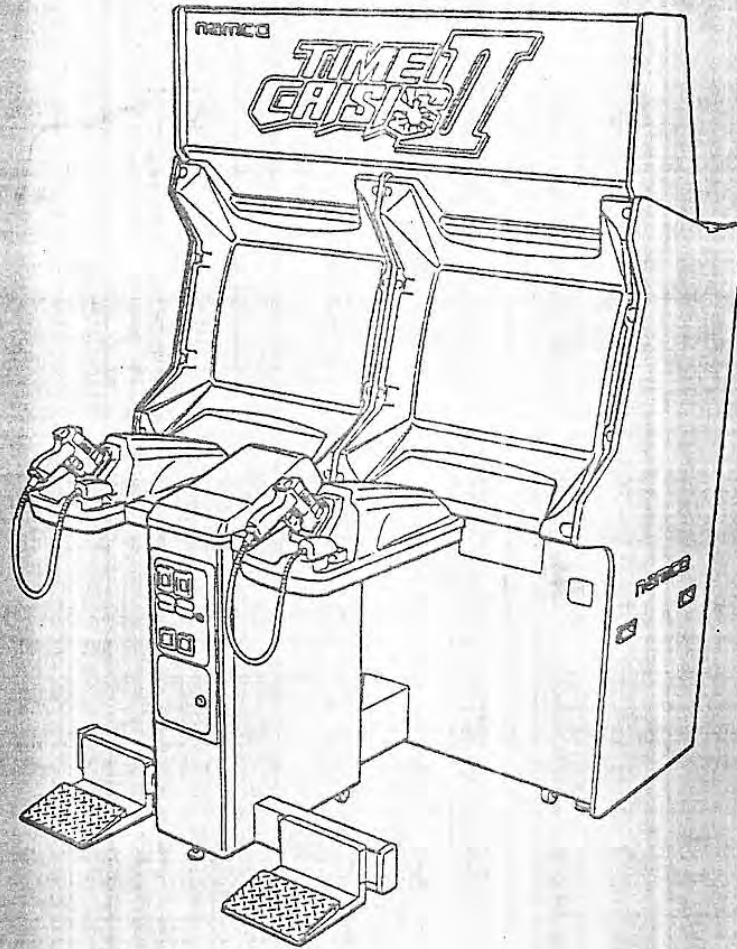

Time Crisis 2

OPERATION MANUAL

The real product you have received may differ slightly from what is illustrated.



DANGER

- Be sure to read this Operation Manual before using your machine to ensure safe operation.
- Store the Operation Manual in a safe place for quick access.

Important

**Read PRECAUTIONS and INSTALLATION
Sections before operating game**

FCC Notice

Note: This equipment has been tested and found to comply with the limits for a Class A digital device, pursuant to Part 15 of the FCC Rules. These limits are designed to provide reasonable protection against harmful interference when the equipment is operating in a commercial environment. This equipment uses, and can radiate radio frequency energy and, if not installed and used in accordance with the instruction manual, may cause harmful interference to radio communications. Operation of this equipment in a residential area is likely to cause harmful interference in which case the user will be required to correct the interference at his own expense.

Copyright 1996 NAMCO AMERICA INC. - All rights reserved

No part of this publication may be reproduced by any mechanical photographic, or electronic process, or in the form of a phonographic recording, nor may it be stored in a retrieval system, transmitted, or otherwise copied for public or private use, without permission from NAMCO AMERICA INC.

INTRODUCTION

Thank you very much for purchasing Namco's Time Crisis 2 ("this machine").

This Operation Manual describes:

- how to run, install, transport, move, maintain, and scrap this machine safely
- how to run this machine correctly while making full use of its functions
- how to ensure safety for players and observers.

Whom to contact when you need information about this machine and its repairs

- For information about this machine and its repairs, contact your dealer.

1. SAFETY PRECAUTIONS



Be sure to read these instructions to ensure safe use.

Instructions to the owner:

If you wish to commission another party to run, install, transport, move, maintain, or scrap this machine, please instruct that party to read and observe all instructions for the particular action to be conducted.

1-1 Magnitudes of risk

For this machine and this Operation Manual, safety precautions and property damages are classified as listed below according to the magnitude of the particular risk.

-  **DANGER:** Failure to avoid the risk will most probably result in death or serious injury.
-  **WARNING:** Failure to avoid the risk may result in death or serious injury.
-  **CAUTION:** Failure to avoid the risk may result in minor injury or property damage.

Functional notes not related to safety are marked with the following label:



Notes related to a function and protection of the product

1-2 Definition of the term “technician”

This Operation Manual is designed for arcade game shop personnel. However, those sections marked “To be conducted by a technician only” in the table of contents are written for technicians. Such tasks must therefore be conducted by a technician only.

Technician:

A person engaged in machine design, manufacture, inspection, or maintenance for a manufacturer of amusement equipment, or a person who has technical knowledge related to electricity, electronics, and mechanical engineering at a level equal to or superior to that of graduates of industrial high school, and who engages routinely in maintaining (repairing) amusement equipment.

1-3 Top-priority safety precautions



WARNING

- Should any trouble occur, turn off the power and stop operating this machine immediately. Then do not forget to unplug the power cord. Running this machine with its trouble unsolved may cause a fire or other accident.
- Some parts in the monitor retain high heat and voltage after power-off. Take care not to touch any such part without proper protection. Such a touch might give you an electric shock or get you burned.
- Dust accumulated on the power plug may cause a fire. Conduct a regular check and remove dust.
- Insert the power plug into the service outlet securely. Poor contact may cause heat, resulting in a fire or getting you burned.
- A breakdown of the power cord may cause a fire, an electric shock, or leakage. Observe the following instructions:
 - Do not make the cord come close to a heating device.
 - Do not twist the cord.
 - Do not bend the cord forcibly.
 - Do not modify it.
 - Do not bundle it.
 - Do not pull it. (To pull out the power plug, do not pull the cord. Always hold the power plug to pull it out.)
 - Do not place anything on it.
 - Do not get it caught by this machine, other product, or wall.
 - Do not do anything else that may damage the power cord.
- Do not wet the power cord or power plug with water. That might cause an electric shock or leakage.
- Do not touch the power plug with a wet hand. That might give you an electric shock.
- This machine has a power capacity of 110V AC, 5.2A (220V AC, 2.6A). Always use indoor wiring that conforms to this machine's power specifications. Otherwise a fire or an electric shock might result.
- Run this machine with a supply voltage in the 110-120V AC (or 220-240V AC) range. Using this machine at any voltage outside the specified range might cause a fire or electric shock. To ensure this machine runs under its best condition, use a rated voltage whenever possible.
- Use specified brands of consumables and service parts (including screws). To order any part, contact your dealer.
- Do not remodel this machine without permission. Do not carry out any task not covered in this Operation Manual. Unauthorized remodeling may result in an unexpected risk.
- In re-selling this machine, always attach this Operation Manual to this machine.

1-4 Description of the "warning label" attached to this machine

WARNING

- The "warning label" describes important safety precautions. Observe the following:
 - As the "warning label" attached to this machine should be read easily, take care to decide the place to install this machine and the appropriate illumination or soil of the warning labels. Do not let this label get hidden behind another gaming machine or other object.
 - Do not remove or modify the "warning label."
 - When the "warning label" is dirty or damaged, replace it with a new "warning label." To order an additional "warning label," contact your dealer.



※ High-voltage parts refer to certain parts at the back of the monitor. (See P-51, 8-3-1 (2) "Replacing the Monitor with a New One.")

Warning sticker (high voltage)
Part # 461-371



※ High-voltage parts refer to certain parts at the back of the monitor. Before work, read P-51, 8-3-1 (2) "Replacing the Monitor with a New One."

Warning sticker (inside)
Part # 461-376

(This "warning label" is attached inside this machine.)

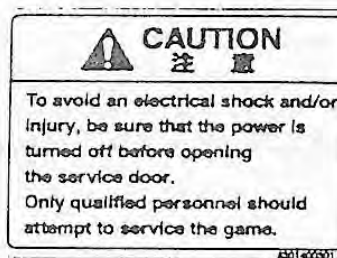
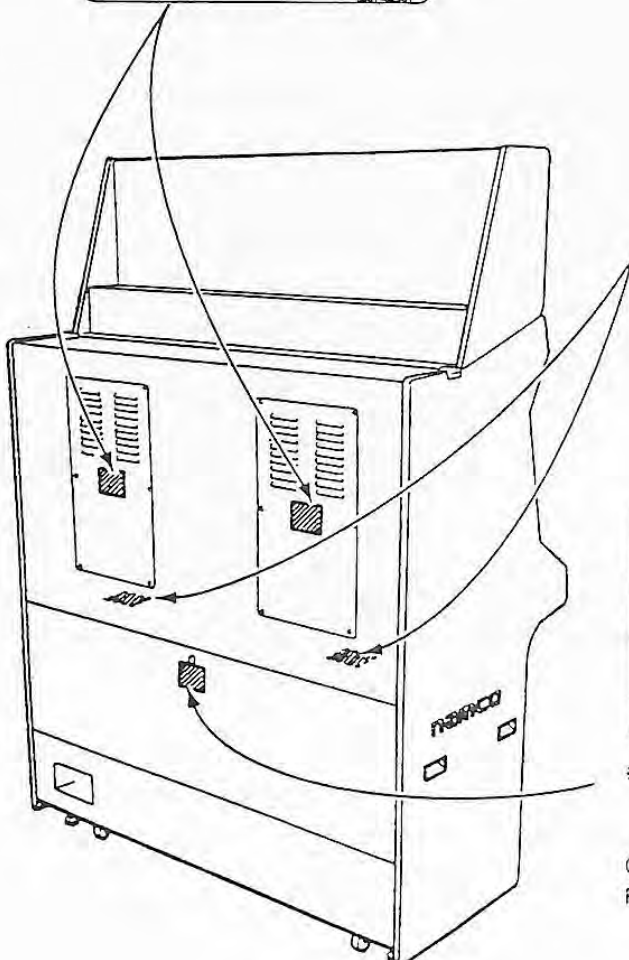

※ The parts inside refer to the amplifier board, regulator, and related parts on the control base.

Caution sticker (maintenance)
Part # 461-359

CONTENTS

1. SAFETY PRECAUTIONS	1
1-1 Magnitudes of risk	1
1-2 Definition of the term "technician"	1
1-3 Top-priority safety precautions	2
1-4 Description of the "warning label" attached to this machine	3
CONTENTS	4
2. SPECIFICATIONS	7
3. CHECKING THE PACKAGE CONTENTS	9
4. OVERALL CONSTRUCTION (COMPONENTS AND THEIR NAMES)	10
5. INSTALLATION	11
5-1 Conditions for installation	11
5-1-1 Locations to avoid installing	11
5-1-2 Play zone as installed	12
5-2 Required dimensions of carry-in passage (such as doors and corridors)	13
5-2-1 Dividing the signboard Assy and cabinet Assy	14
5-3 Assembly	15
5-3-1 Connecting the cabinet Assy to the tower Assy	15
5-3-2 Installing the pedal Assy	17
5-4 Connecting the power cord and the ground	18
(1) With a 3P service outlet	18
(2) With a 2P service outlet	18
(3) If the 2P service outlet available has no ground terminal	19
6. MOVING AND TRANSPORTING	20
6-1 Moving (on the floor)	20
6-2 Transportation	21
6-2-1 Dividing	21
6-2-2 Manual carrying (up or down the stairs, for example)	23
6-2-3 Loading and unloading a vehicle or something similar	24
6-2-4 Trucking	25
7. OPERATING THIS MACHINE	26
7-1 Pre-service check	27
7-1-1 Appearance check	27
7-1-2 Operation check	27
7-1-3 Periodic check	27
7-2 How to play	28
7-2-1 How to control	28

7-2-2	Modes	28
7-2-3	Rules	28
7-3	Adjustment	29
7-3-1	Turn on the power switch	29
7-3-2	Adjustment switches	29
7-4	Test mode	31
7-4-1	Description of the menu screen	31
7-4-2	Setting a game fee and free play (COIN OPTIONS)	32
7-4-3	Setting the type of game (GAME OPTIONS)	33
7-4-4	I/O tests for switches (I/O TEST)	34
7-4-5	MONITOR TEST	38
7-4-6	SOUND TEST	39
7-4-7	Displaying and initializing game data (ADS DATA)	40
7-4-8	OTHERS	41
7-5	Setting the gun aiming (GUN INITIALIZE)	42
8.	MAINTENANCE	44
8-1	Maintenance and inspection	44
8-1-1	Greasing the plunger of the pedal Assy	45
8-1-2	Checking the plunger of the pedal Assy for wear and tear	47
8-2	Troubleshooting	48
8-2-1	General	48
8-2-2	Cabinet Assy	48
8-2-3	Signboard Assy	49
8-2-4	Tower Assy	49
8-2-5	Pedal Assy	49
8-2-6	Gun Assy	49
8-3	Disassembling, reassembling and replacing the Assys and parts	50
8-3-1	Cabinet Assy	50
(1)	Detaching and reattaching the rear cover	50
(2)	Replacing the monitor with a new one	51
(3)	Adjusting the monitor	55
(4)	Detaching and reattaching the rack Assy	60
(5)	Replacing the game PC board with a new one	61
8-3-2	Signboard Assy	63
(1)	Replacing the fluorescent lamp and glow lamp with new ones	63
8-3-3	Tower Assy	64
(1)	Replacing the I/O PC board with a new one	64
8-3-4	Pedal Assy	66
(1)	Replacing the microswitch with a new one	66
(2)	Replacing the plunger with a new one	67
8-3-5	Gun Assy	68
(1)	Replacing the gun Assy with a new one	68
(2)	How to open the gun slide	69
(3)	How to open the gun cover	70
(4)	Replacing the solenoid with a new one	71
(5)	Replacing the microswitch with a new one	72
(6)	Replacing the tube with a new one	72

9. DISCARD	73
10. PARTS LIST	74
10-1 Cabinet Assy	74
10-2 Signboard Assy	76
10-3 Control base Assy	78
10-4 Rack Assy	80
10-5 Cord box Assy	82
10-6 Tower Assy	84
10-7 Pedal Assy	86
10-8 Gun Assy	88
10-9 Coin Assy	90
11. WIRING DIAGRAM	93
Cabinet Assy	93
Tower Assy	94

2. SPECIFICATIONS

- (1) Rated power supply : 110V-120V AC or 220V-240V AC (50/60 Hz)
 (2) Maximum power consumption : 450W (for 110V AC power supply)
 440W (for 220V AC power supply)
 (3) Maximum current consumption : (5.2A (for 110V AC power supply)
 (2.6A (for 220V AC power supply)
 (4) Cash box capacity : approx. 300,000 yen (3,000 100-yen coins)
 (5) CRT : 29" color monitor × 2 units
 (6) Dimensions

- ① As installed: 1,500 (W) × 1,510 (D) × 2,090 (H) mm

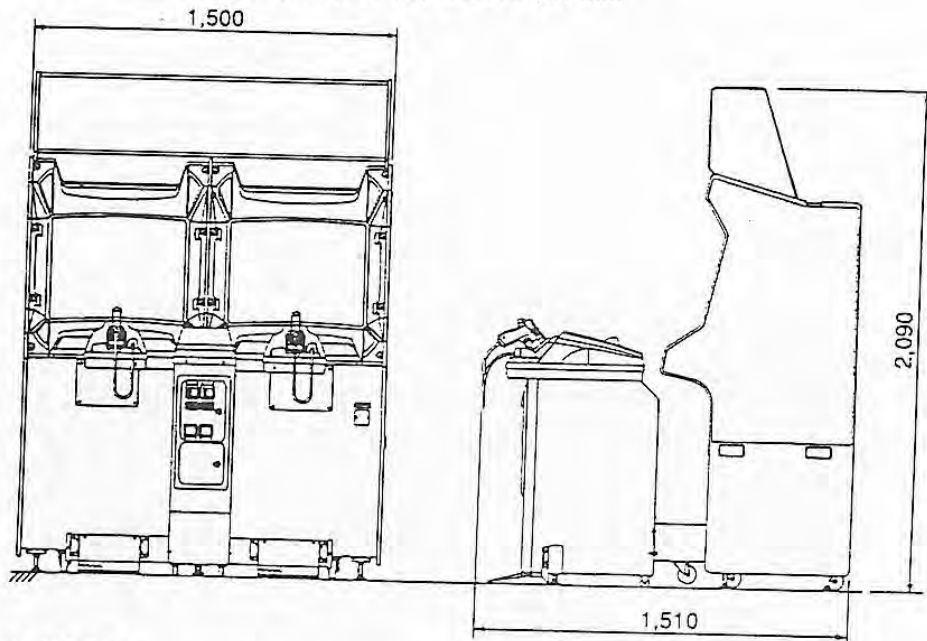

- ② As divided
- | | |
|----------------|--------------------------------------|
| Cabinet Assy | : 1,500 (W) × 790 (D) × 1,730 (H) mm |
| Tower Assy | : 1,100 (W) × 720 (D) × 1,110 (H) mm |
| Signboard Assy | : 1,460 (W) × 380 (D) × 480 (H) mm |
| Pedal Assy | : 250 (W) × 250 (D) × 160 (H) mm |

Cabinet Assy

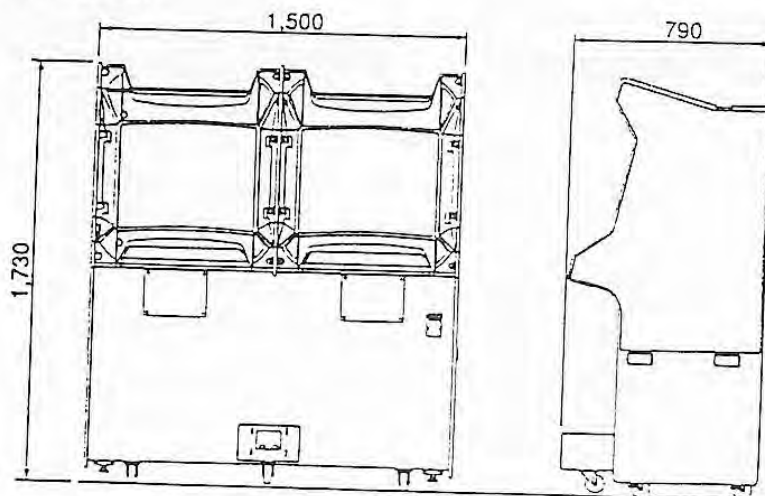

Tower Assy

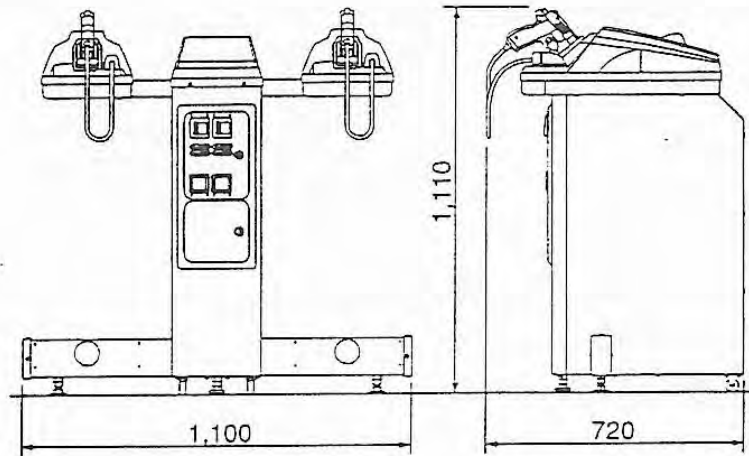

Signboard Assy

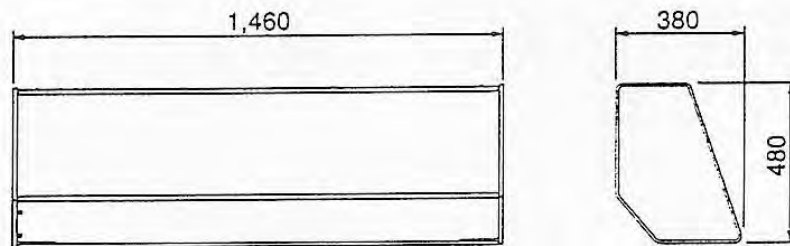

Pedal Assy

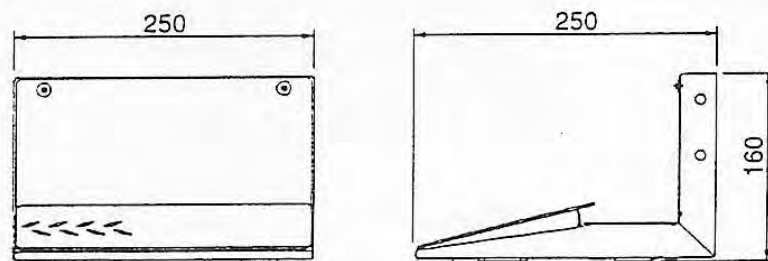

(7) Weight

- ① As installed : 279kg
- ② As divided
 - Cabinet Assy : 205kg
 - Tower Assy : 42kg
 - Signboard Assy : 24 kg
 - Pedal Assy : 4kg × 2

3. CHECKING THE PACKAGE CONTENTS

When packed and shipped, this machine consists of the following:

NOTICE







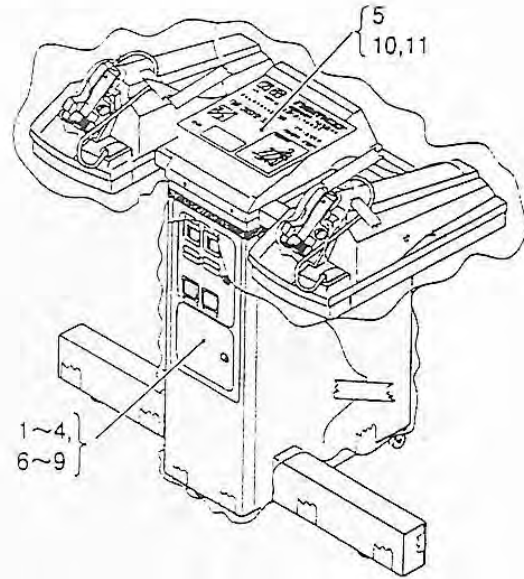
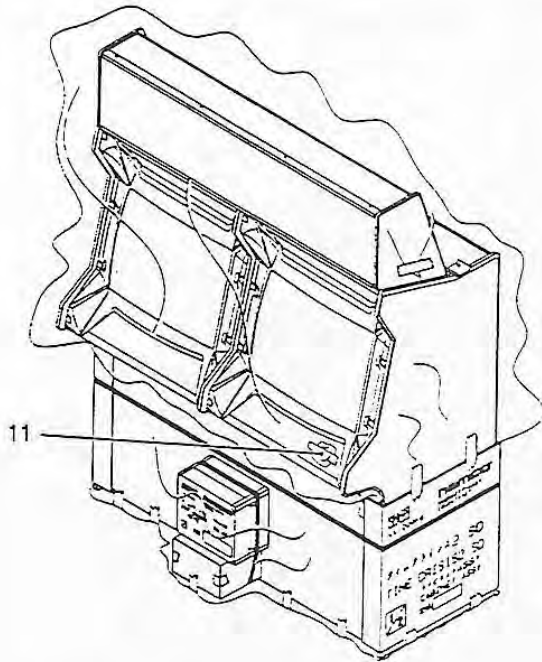



- Be sure to check that you have received all packages indicated below.
- If you find any component missing, contact your dealer.

● Body Assy: 1 unit

● Tower Assy: 1 unit



● Body Assy: 1 unit

No.	Component	Specification	Q'ty
1	Pedal bracket		4
2	Flange socket	M5x12 	8
3	Flange socket	M6x12 	8
4	Flange socket	M8x20 	4
5	Operation Manual (this manual)		1
6	Torque wrench	Diagonal 4mm (for M5) 	1
7	Hexagon wrench	Diagonal 4mm 	1
8	Hexagon wrench	Diagonal 5mm 	1
9	Hexagon wrench	Diagonal 6mm 	1
10	Cash box key		2
11	Key for service door and rear cover		4

4. OVERALL CONSTRUCTION (components and their names)

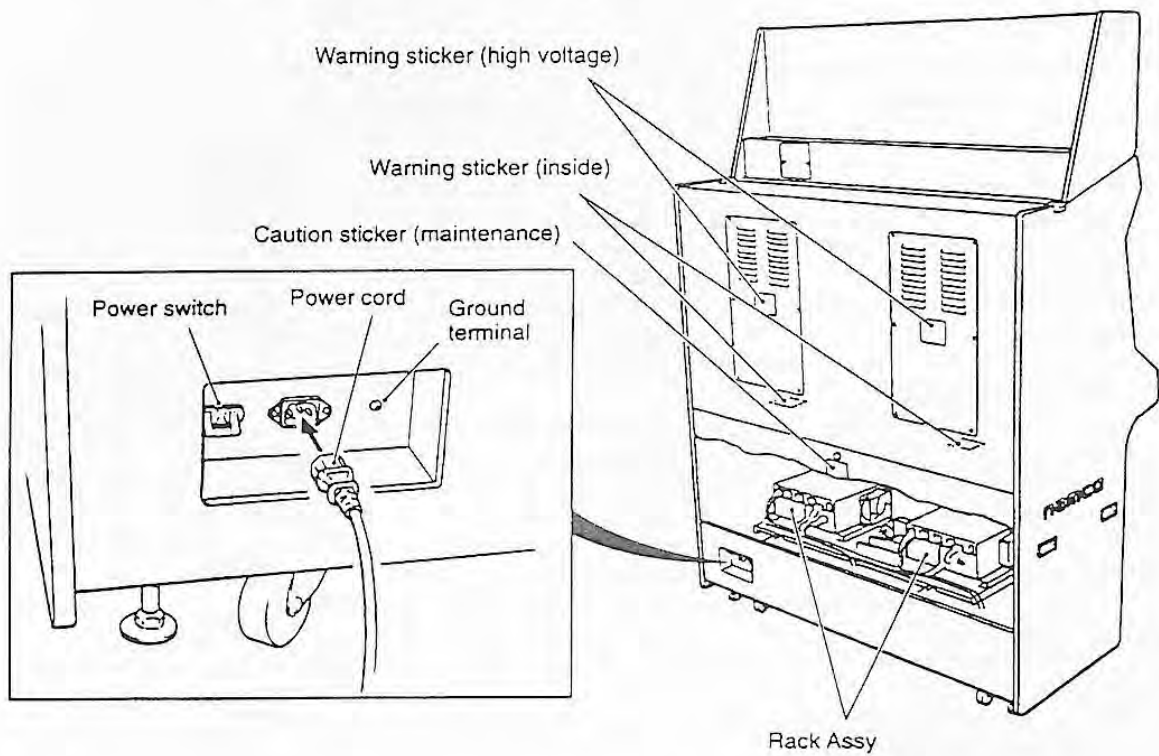
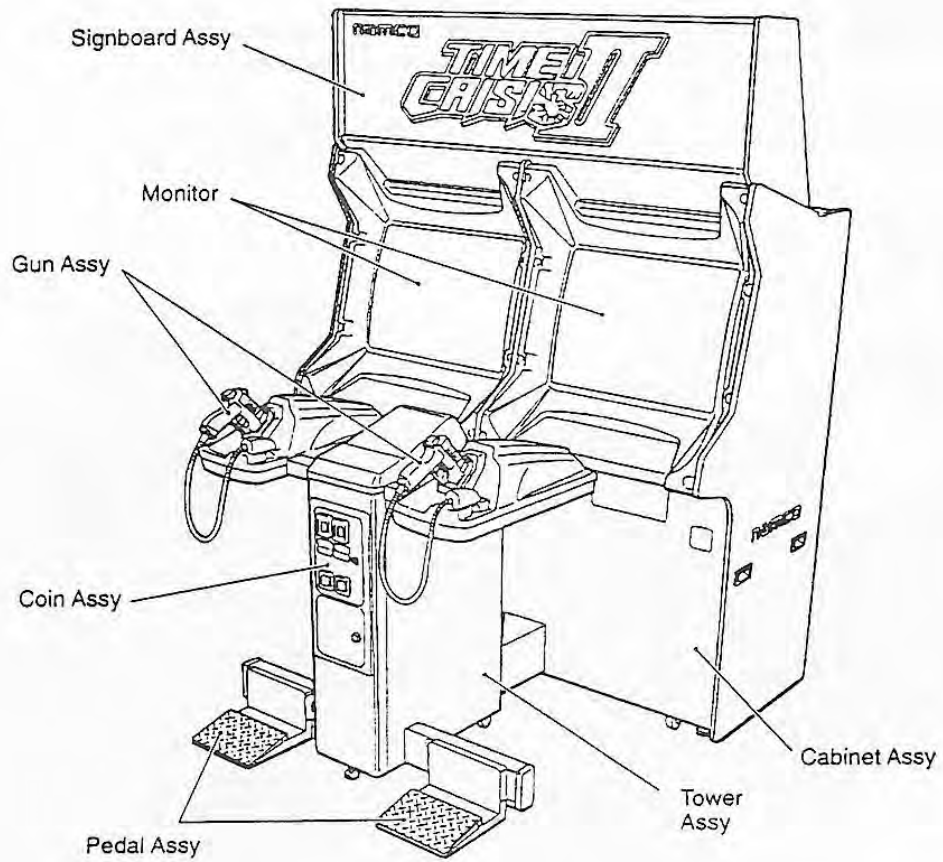

5. INSTALLATION



WARNING

- Install the components according to the descriptions and specified procedures in this Operation Manual (see P-11, 5. Installation). Failure to follow any procedure might result in a fire, electric shock, injury, or breakdown.
- Insert the power plug into the service outlet securely all the way home. Poor contact may cause heat, resulting in a fire or getting you burned.
- Be sure to ground the machine. Failure to ground may cause an electric shock in the case of leakage. (See P-18, 5-4 "How to Connect the Power Cord and Ground.")
- When installing this machine, always fix it with the level adjusters. Failure to fix it may cause an accident or injury.

5-1 Conditions for installation



WARNING

- Do not place an object close to the vent holes in the rear and side of this machine. Do not block any of the vent holes with a wall or other object either. Failure to observe these instructions may heat up the inside of this machine, resulting in a fire or breakdown.

5-1-1 Locations to avoid installing



WARNING

- This machine is designed for indoor use. Never install this machine outdoors or at any of the following locations:
 - Locations exposed to direct sunlight
 - Locations subjected to rain or water leakage
 - Damp places
 - Dusty places
 - Close to a heating instrument
 - Hot places
 - Extremely cold places
 - Places where dew may develop due to temperature differences
 - Places where this machine may become an obstacle in disaster prevention (such as an emergency exit) and places where a fire extinguisher or similar equipment is placed
 - Unstable or vibrating places

5-1-2 Play zone as installed



WARNING

- Set a play zone as illustrated in the figure below to prevent customers leaving this machine from getting into contact with observers and passers-by.

NOTICE

- This machine must be at least 2m 10cm from the ceiling.
- Allow for a clearance of at least 50cm between the rear of this machine on the one hand and the nearby wall and other machinery on the other in order to facilitate the removal of the rack Assy and control base Assy for maintenance.

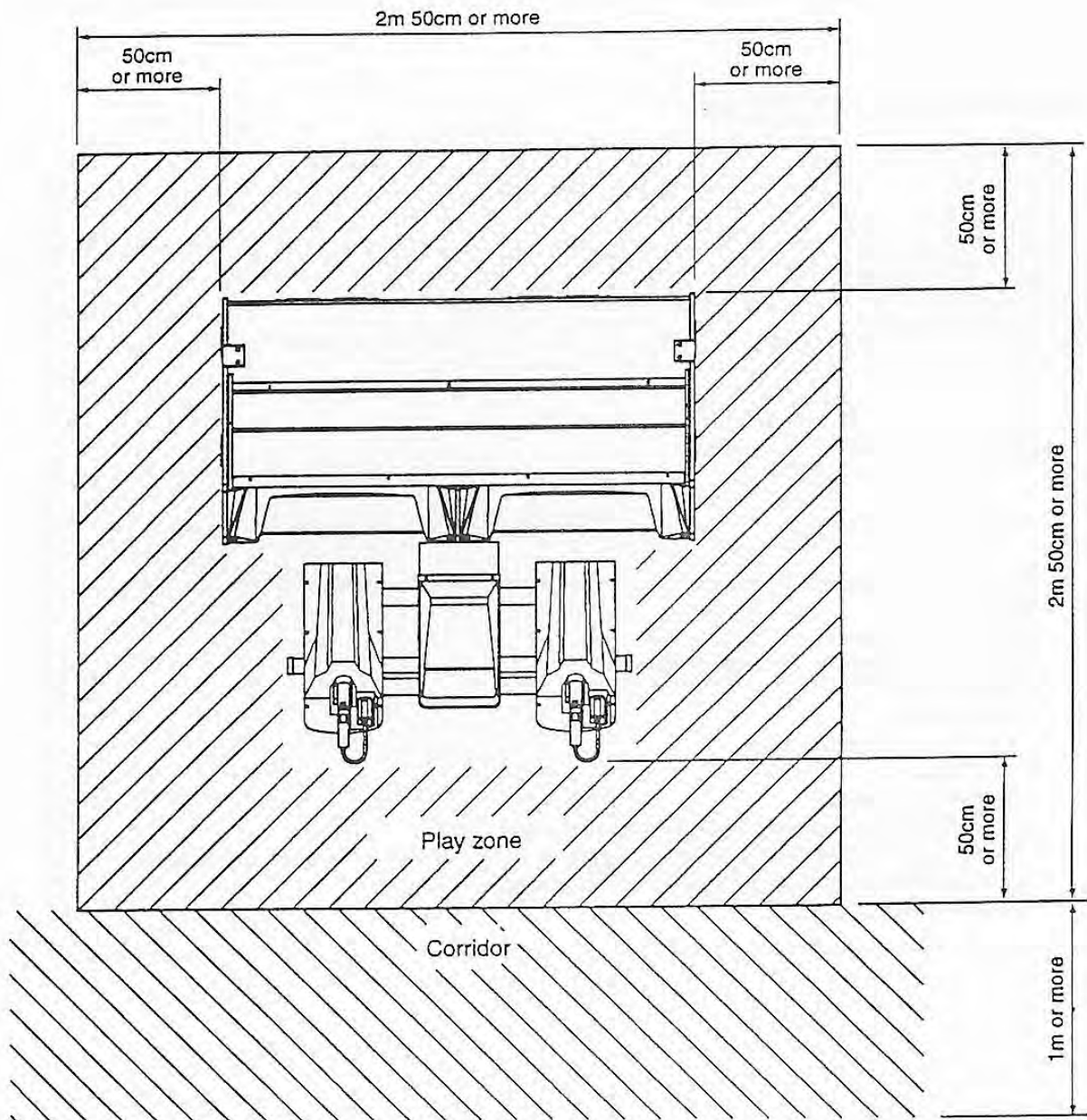

5-2 Required dimensions of carry-in passage (such as doors and corridors)

This machine is shipped as divided. The divisions have the dimensions mentioned below.

- Body Assy : 1,500 (W) × 790 (D) × 2,090 (H) (mm)
Weight: 229kg
- Tower Assy : 1,100 (W) × 720 (D) × 1,110 (H) (mm)
Weight: 42kg

The carry-in passage must therefore be large enough to be equal to or exceed the dimensions listed above.

Depending on the conditions of the access door, the body Assy can be divided into halves as indicated below.

- Signboard Assy : 1,460 (W) × 380 (D) × 480 (H) (mm)
Weight: 24kg
- Cabinet Assy : 1,500 (W) × 790 (D) × 1,730 (H) (mm)
Weight: 205kg

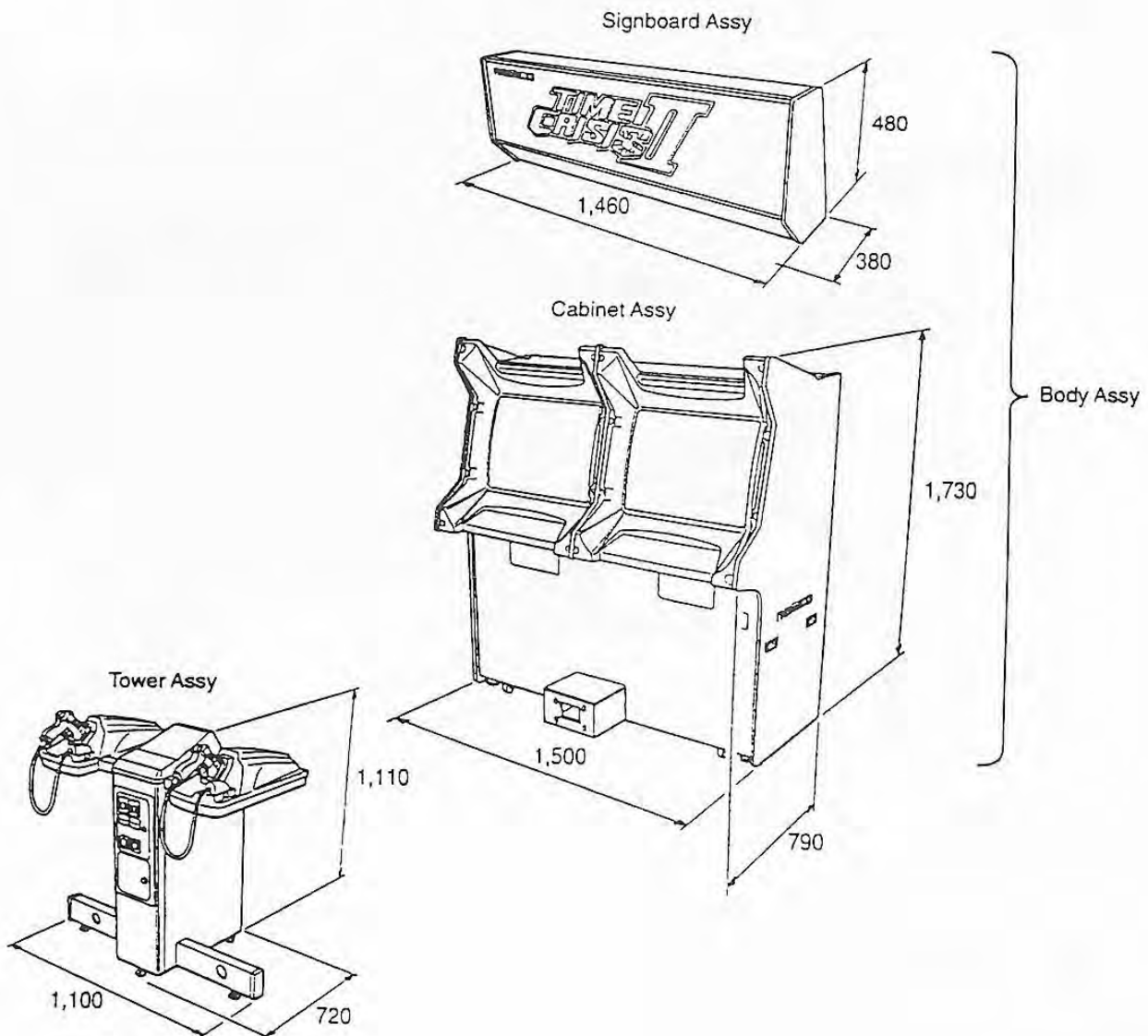

5-2-1 Dividing the signboard Assy and cabinet Assy

– To be conducted by a technician only –

- This task need not be conducted if the ceiling above the carry-in passage and the opening of the access door are high enough.



WARNING

- The signboard weighs about 24kg. In removing it, allow for at least two workers and a sufficient working space to avoid accidents.

- 1** Remove the two torque bolts (M5 × 12) from the back of the signboard Assy and detach the connector cover.
- 2** Unplug the connector of the signboard Assy.
- 3** Remove the three hexagon bolts (with flat and spring washers) (M6 × 30).
- 4** Slide the signboard Assy backwards to the rope hook. Lift and remove the signboard Assy.

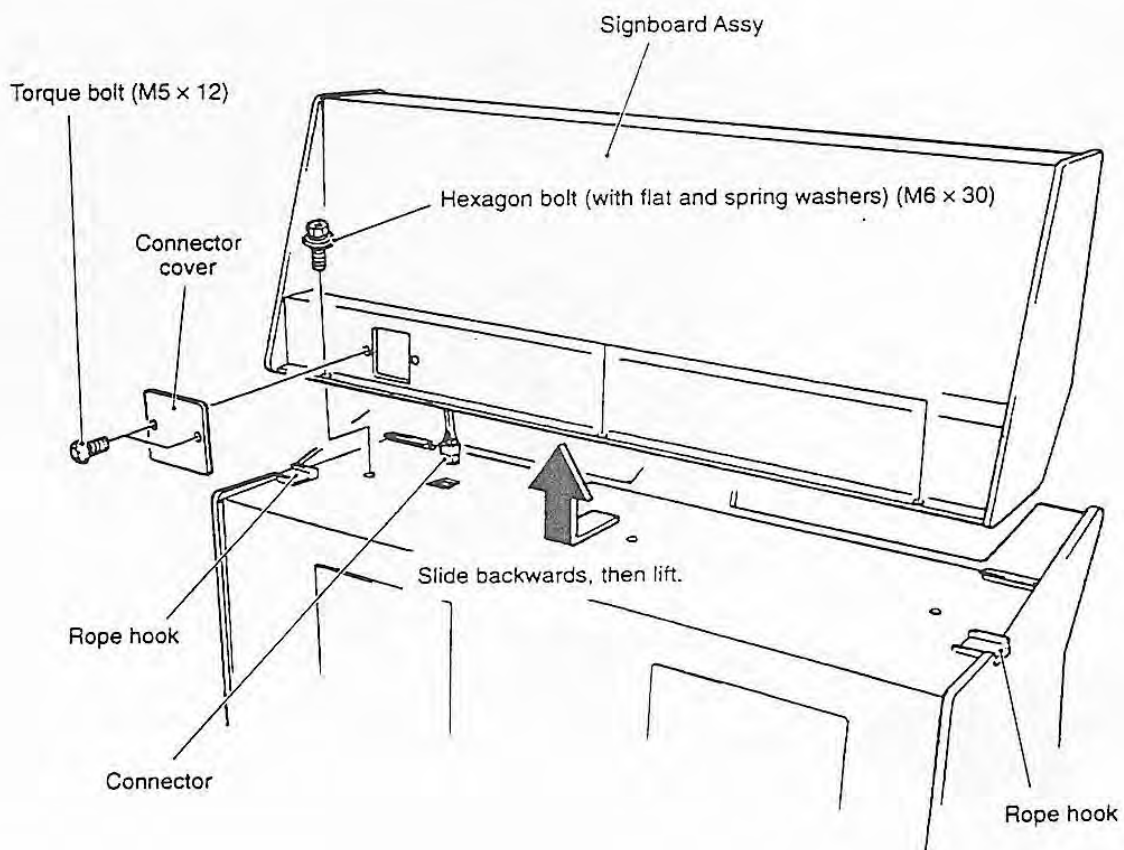

- 5** In re-coupling these components together, follow reverse order.

5-3 Assembly

5-3-1 Connecting the cabinet Assy to the tower Assy

– To be conducted by a technician only –



- Install this machine at a position where the monitor does not reflect the incandescent lamp. Such reflection might prevent the gun sensor from functioning. (A fluorescent lamp is tolerable.)

- 1 Install the cabinet Assy according to P-11, 5-1 "Conditions for Installation." Then lower the four level adjusters until the casters are about 5mm from floor level (so as to rotate freely).

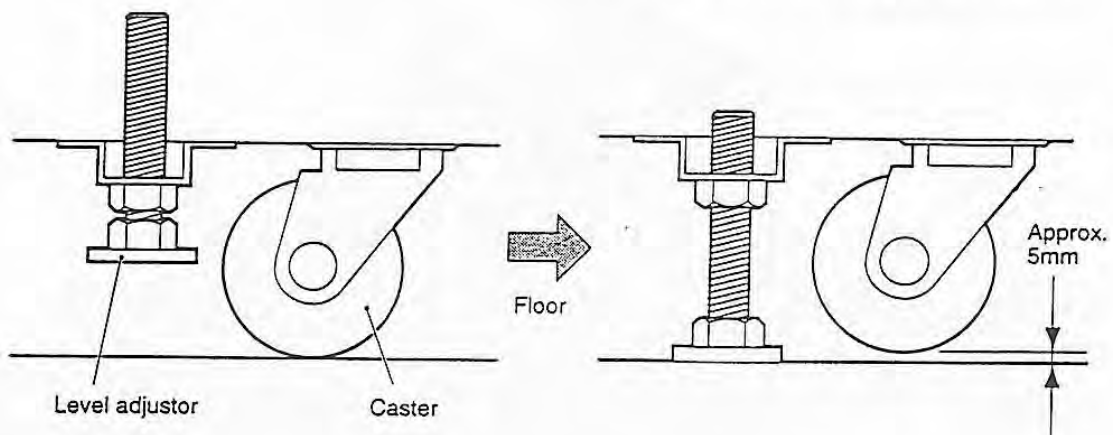

- 2 Remove the four torque bolts (M5 × 12) from the cabinet Assy and detach the joint cover.
- 3 Install the tower Assy, fitting it to the joint.

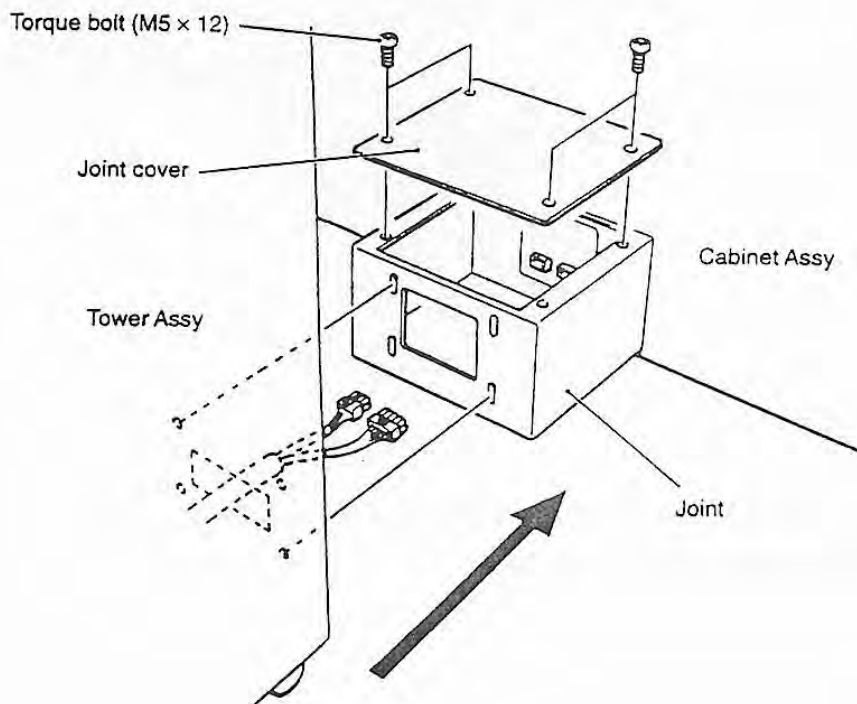

- 4 Fix the tower Assy with four flange sockets (M8 × 20) furnished with this machine.
- 5 Pull out the harness from the tower Assy, then connect the two connectors to the cabinet Assy.

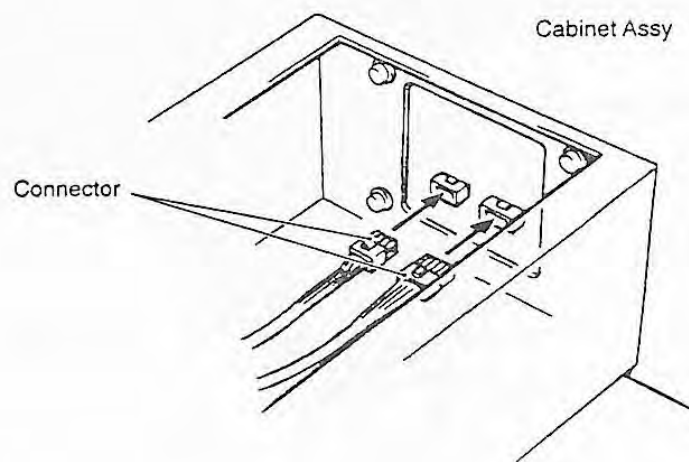
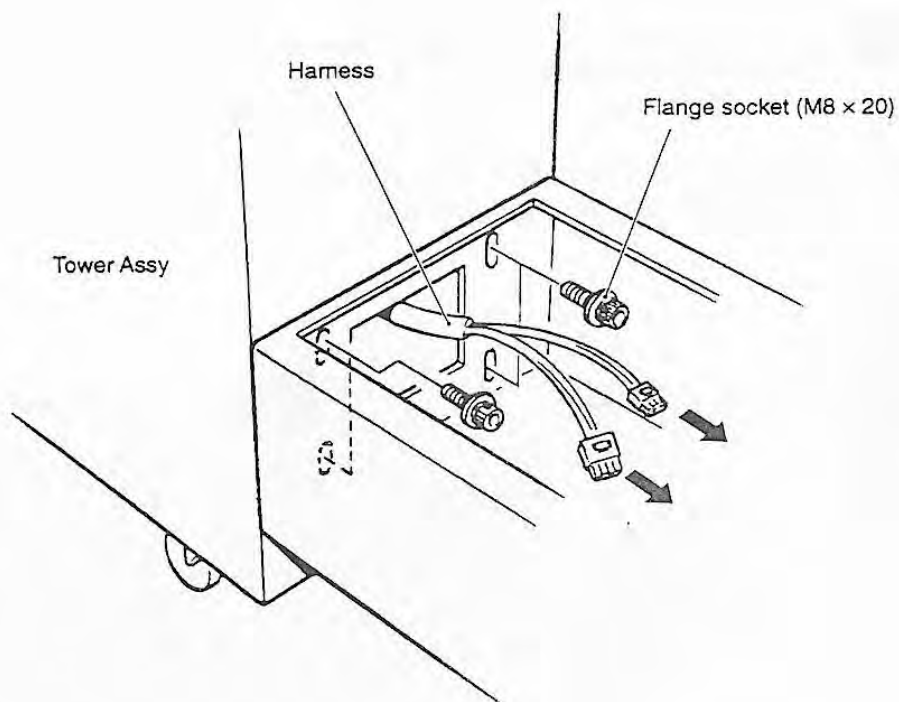

- 6 With four torque bolts (M5 × 12), attach the joint cover removed in step 1.
- 7 When disassembling, follow reverse order.

5-3-2 Installing the pedal Assy

– To be conducted by a technician only –

- 1 Tack four pedal brackets furnished with this machine to the right and left under-pipes of the tower Assy with eight flange sockets (M6 × 12).

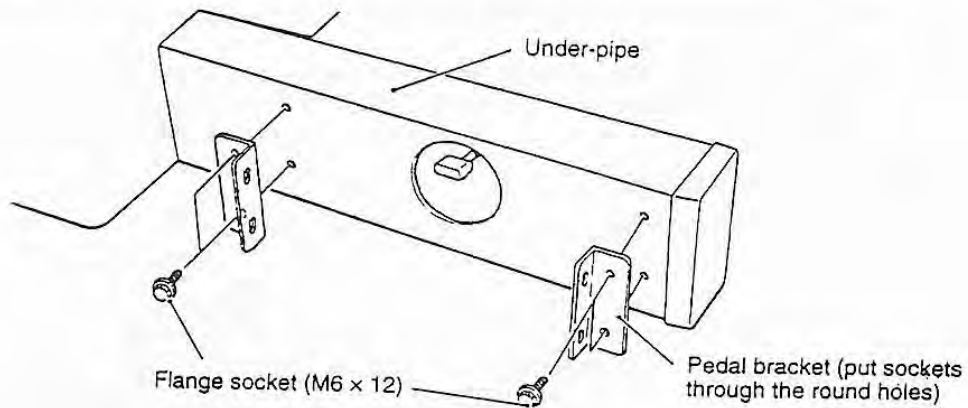

- 2 Connect the connectors of the pedal Assy and the tower Assy, then insert the pedal Assy between the pedal brackets.
- 3 Tighten the flange sockets tacked in step 1 fixing the pedal Assy between pedal brackets.

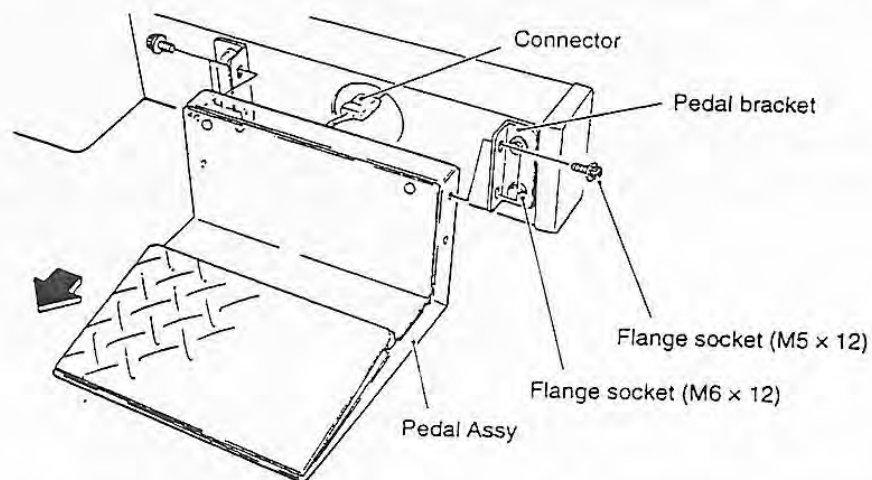

- 4 Press the pedal Assy down against the floor, then fix it with the attached four flange sockets (M5 × 12). (Make sure that the pedal Assy does not come off the floor.)

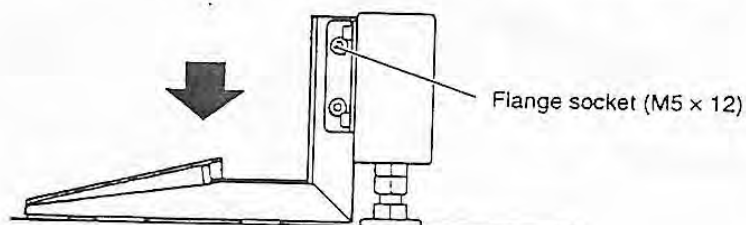

- 5 Fix another one for the opposite side similarly.
- 6 When disassembling, follow reverse order.

5-4 Connecting the power cord and the ground

WARNING

- Be sure to install the ground conductor in either of the methods described below. Failure to install a ground conductor may cause an electric shock in the case of a leakage.
 - (1) Ground the ground conductor with a 3P plug.
 - (2) (If the ground conductor cannot be grounded with a 3P plug,) ground the ground conductor with a 3P-2P conversion plug.
 - (3) (If the ground conductor cannot be grounded with either a 3P plug or a 3P-2P conversion plug,) ground the machine by connecting the grounding wire to the ground terminal of this machine.

(1) With a 3P service outlet

Simply insert the power plug.

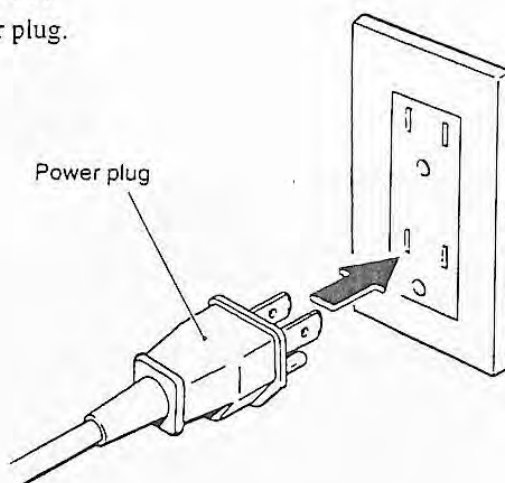

(2) With a 2P service outlet

Ground the ground conductor with the 3P-2P conversion plug furnished with this machine.

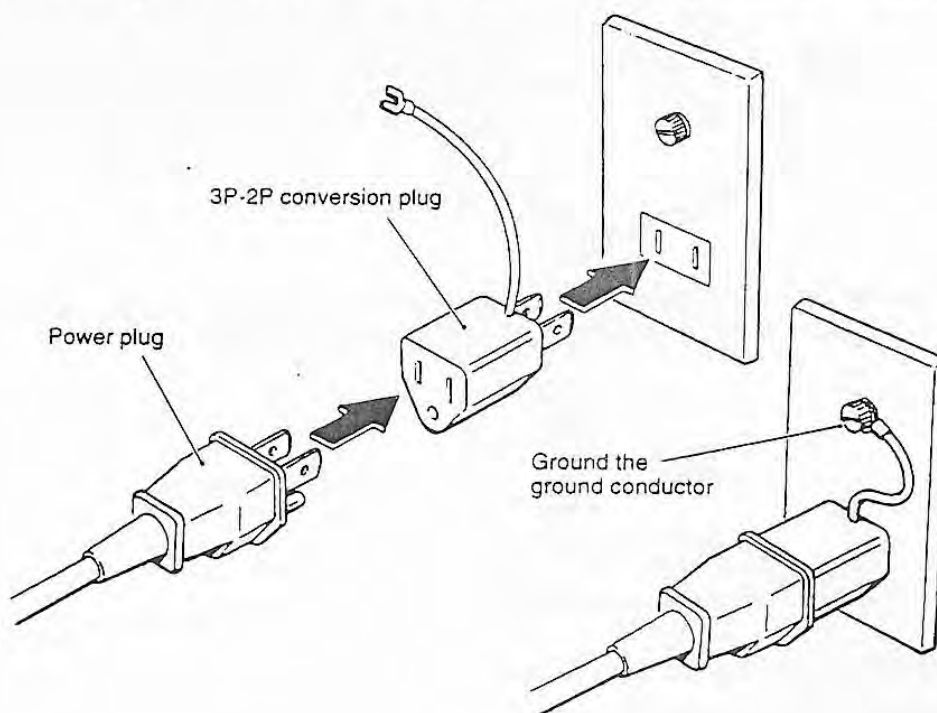

(3) If the 2P service outlet available has no ground terminal

Ground the ground conductor by linking it to the ground terminal at the rear of the cabinet Assy.
 (No ground conductor is furnished with this machine.)

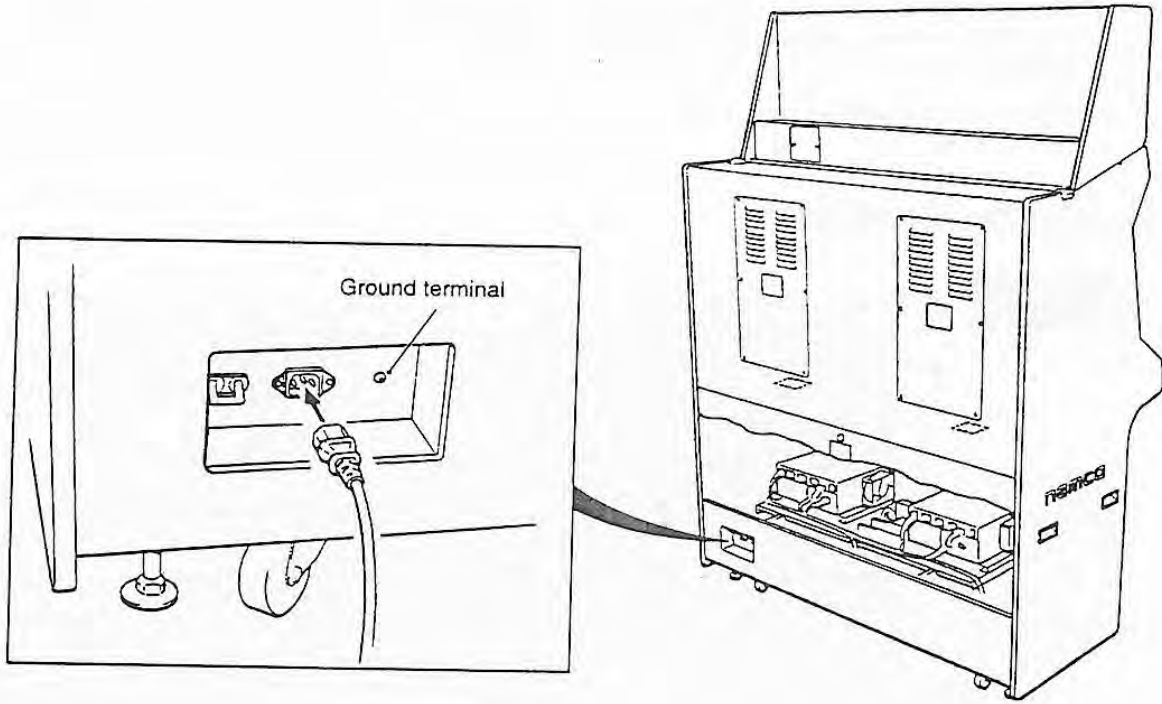

NOTICE

● Install the ground conductor as illustrated below.

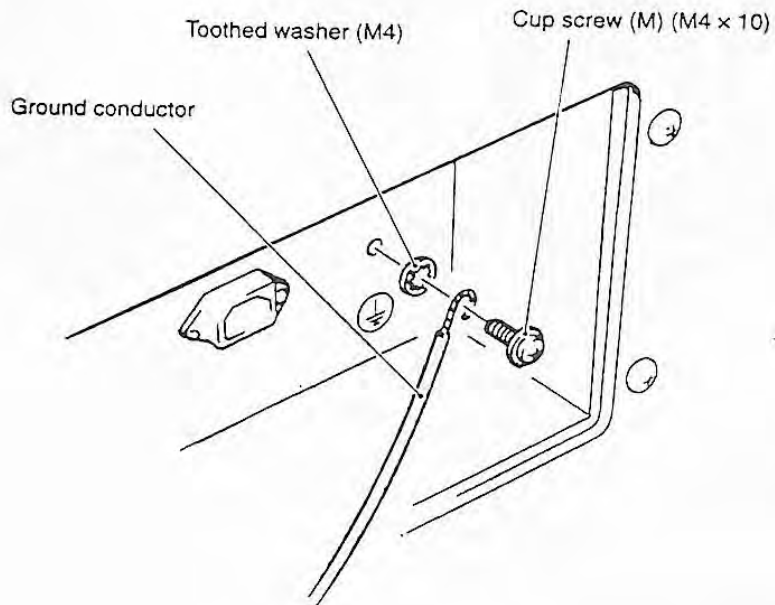

6. MOVING AND TRANSPORTING



WARNING

- Do not leave this machine on a slope. Leaving it on a slope may result in the machine falling down or causing an unexpected accident.
- The tower Assy is not designed to be carried with a forklift. Do not use a forklift for moving and transporting this machine. Using a forklift may cause this machine to fall down or cause an unexpected accident.

6-1 Moving (on the floor)

NOTICE

- If two or more of the cabinet Assy, tower Assy, and pedal Assy are coupled together, be sure to divide this machine into assemblies while referring to P-21, 6-2-1 "Dividing."
- Before moving any assembly either over a short or a long distance, always retract the level adjusters of the cabinet Assy all the way home. (Do not adjust the level adjusters of the tower Assy.)
- The body Assy is 2m 9cm in overall height. Watch out for the heights of the door opening and ceiling of the corridor. (In removing the signboard Assy, see P-14, 5-2-1 "Dividing the Signboard Assy and the Cabinet Assy.")
- Transport the assemblies carefully, keeping them intact. (See the figure below.)
- The molds are fragile. Do not apply a strong force to any of them.

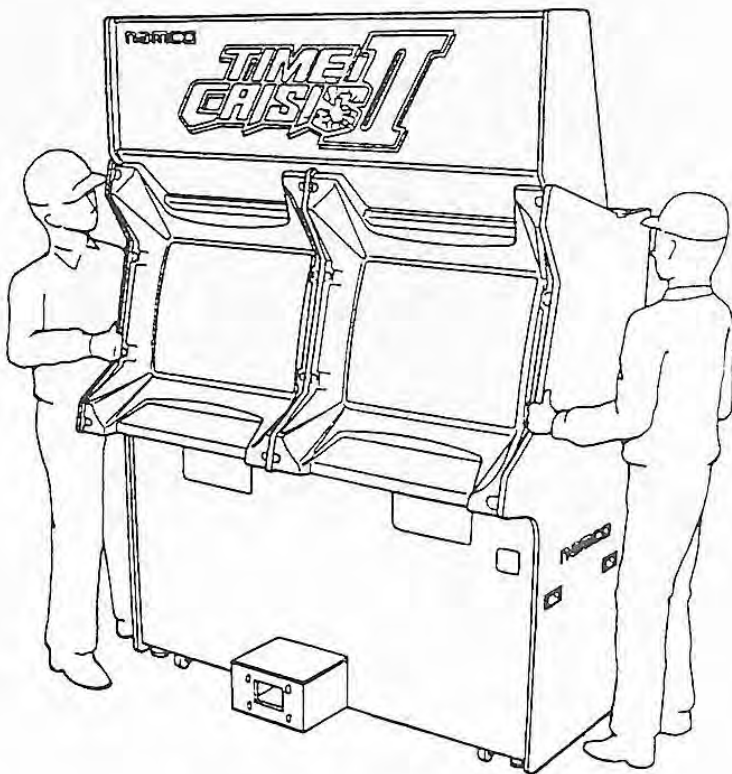

How to carry the cabinet Assy

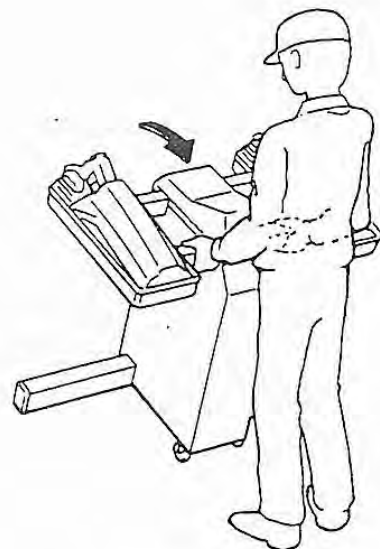

How to carry the tower Assy

6-2 Transportation

6-2-1 Dividing

– To be conducted by a technician only –

- 1 Remove the four flange sockets (M5 × 12), four flange sockets (M6 × 12), pedal brackets, and one connector to detach the pedal Assy. (Do the same at the opposite side.)

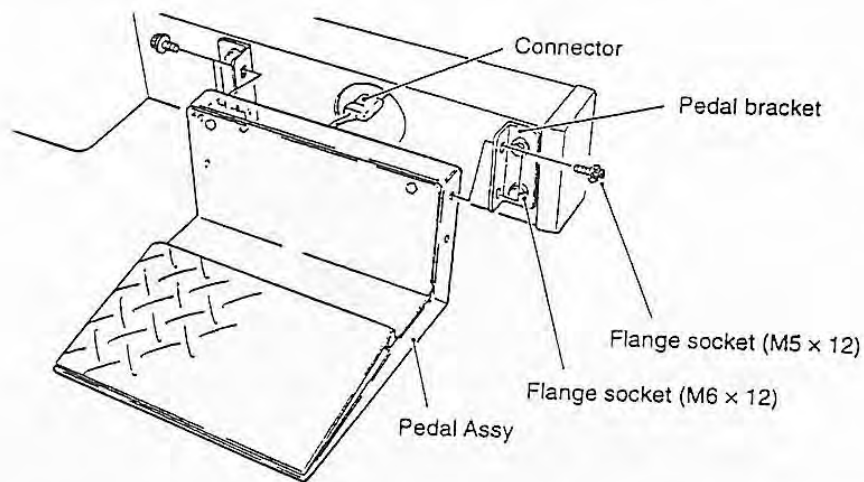

- 2 Remove the four torque bolts (M5 × 12) of the cabinet Assy, then detach the joint cover.
- 3 Remove the two connectors.

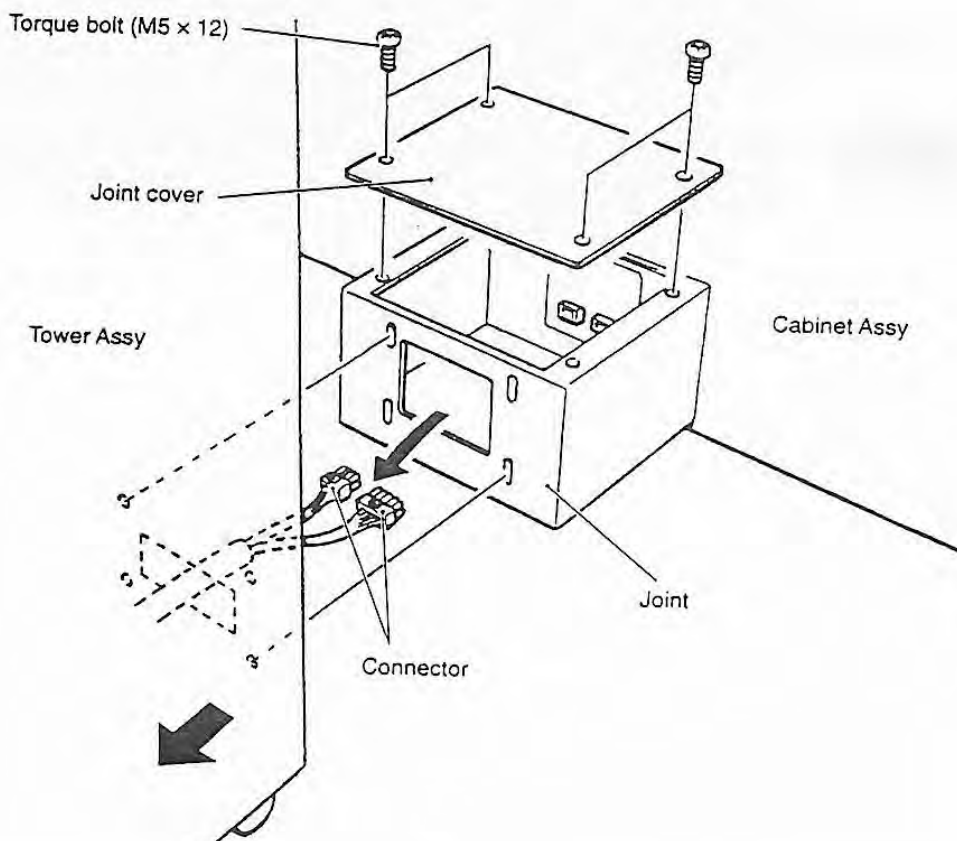

- 4 Remove the four flange sockets (M8 × 20) from the tower Assy.
- 5 Detach the tower Assy from the cabinet Assy. After the detachment, house the portion of the harness that sticks out of the tower Assy.

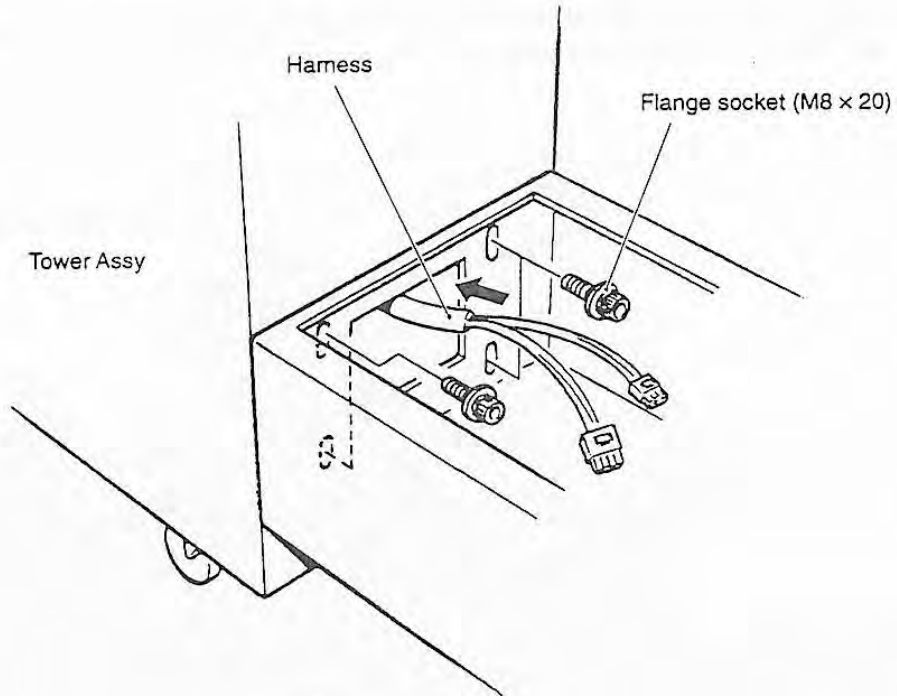

- 6 Fix the joint cover with four torque bolts (M5 × 12).

NOTICE

- If the ceiling of the passage corridor or the top of the access door is too low, disassemble the signboard Assy for transportation. (See P-14, 5-2-1 "Dividing the Signboard Assy and the Cabinet Assy.")

6-2-2 Manual carrying (up or down the stairs, for example)

**WARNING**

- Be sure to divide this machine into the cabinet Assy, signboard Assy, tower Assy, and pedal Assy. Transporting any combination of assemblies without dividing them may result in an accident or injury. (See P-14, 5-2-1 "Dividing the signboard Assy and cabinet Assy" and P-21, 6-2-1 "Dividing.")
- Manual carrying must always be conducted by the appropriate number of people specified below. Any attempt to carry any machinery by an insufficient number of people may result in an accident or injury.
 - * Cabinet Assy (205kg) : 9 people or more
 - * Signboard Assy (24kg) : 2 people or more
 - * Tower Assy (42kg) : 2 people or more

How to carry the cabinet Assy manually

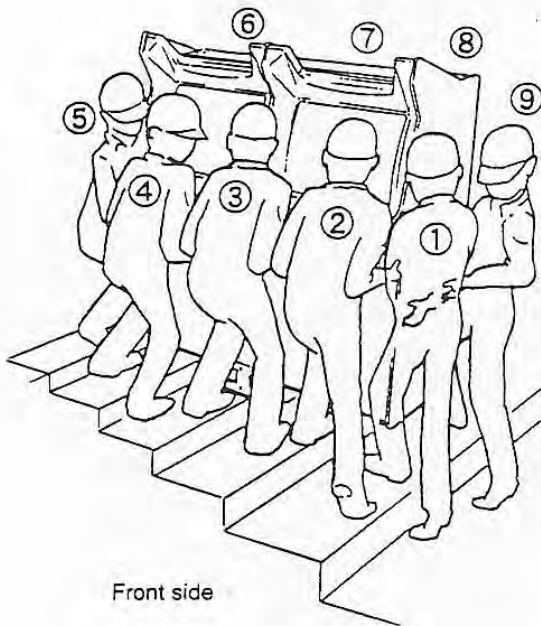

Front side

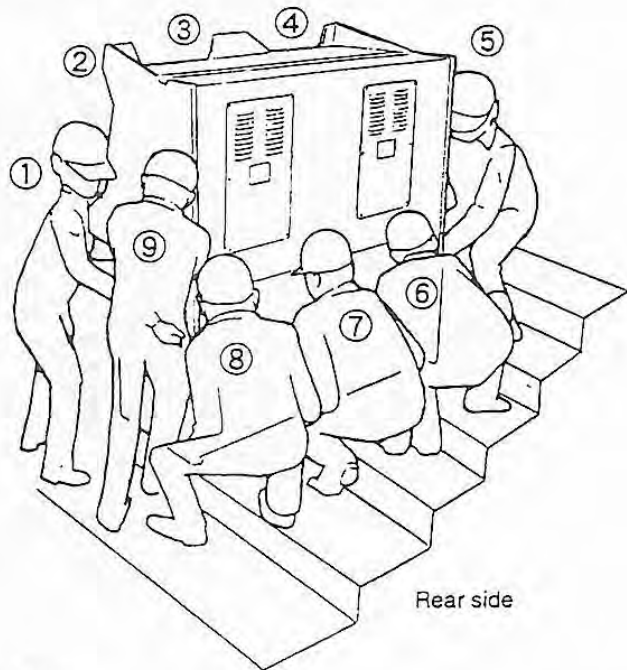

Rear side

Tower Assy

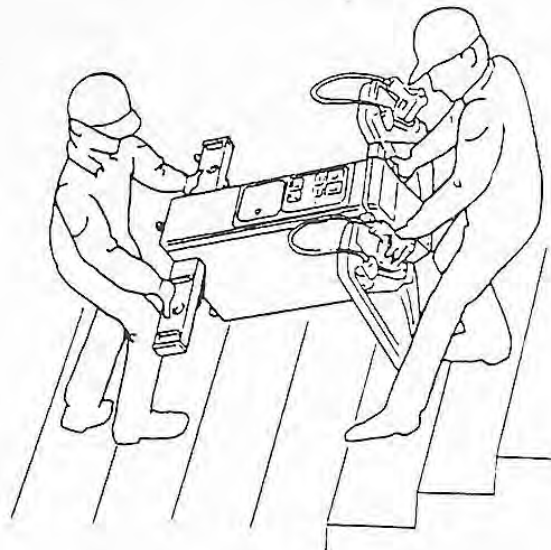

6-2-3 Loading and unloading a vehicle or something similar



WARNING

- Be sure to divide this machine into the body Assy, tower Assy, and pedal Assy. (See P-21, 6-2-1 "Dividing.")
- Note the fork stickers when moving and transporting the body Assy with a forklift.
- The tower Assy is not designed to be transported with a forklift. Do not use a forklift for moving or transporting this machine. Using a forklift may cause this machine to fall down or cause an unexpected accident.



NOTICE

- Transport every component carefully while taking care not to damage it.
- The molds are fragile. Do not apply a strong force to any of them.
- Always retract the level adjustors all the way home.
- In lowering any component from a higher level, do not let it get shocked.

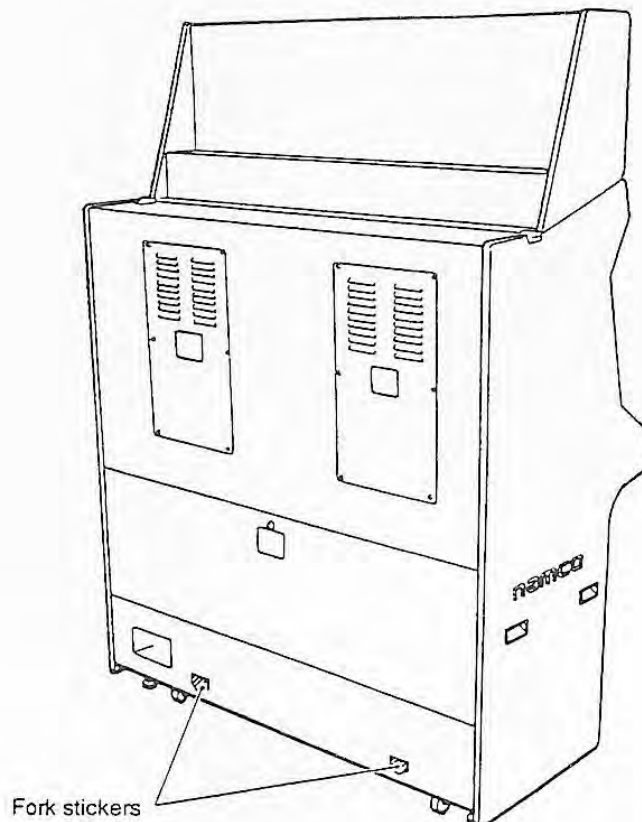

6-2-4 Trucking

**WARNING**

- When transporting this machine on a vehicle, fasten the machine firmly so that it will not start moving due to speedup or slowdown. Failure to fasten it might cause an accident.

NOTICE

- When lowering any equipment from a higher level, do not let it get shocked.
- In roping any equipment, observe the following:
 - Always apply ropes to the positions indicated in the diagram below to fasten the equipment.
 - Insert a pad made of Styrofoam or something similar between the rack and this machine to protect the surface of the machine.

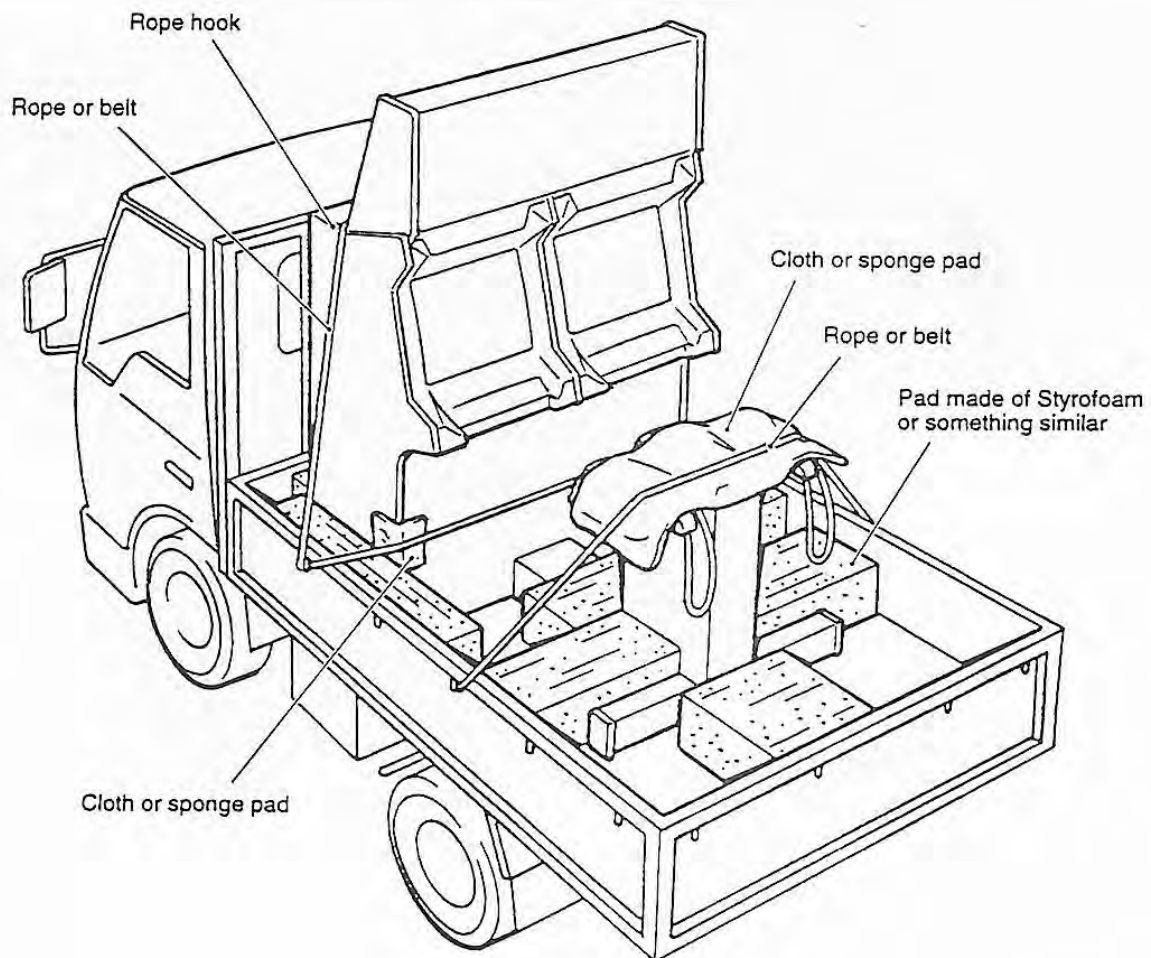

7. OPERATING THIS MACHINE



WARNING

- If any trouble should occur, turn off the power switch immediately and stop operating this machine. Then be sure to unplug the power cord. Operating this machine with its trouble unsolved may cause a fire or accident.
- Dust accumulated on the power plug may cause a fire. Therefore conduct a regular check and remove dust.
- Insert the power cord into the service outlet securely. Poor contact may heat up this machine, resulting in a fire or getting you burned.
- Always make sure that you have installed this machine according to the descriptions and specified procedures given in this Operation Manual (see P-11, 5. "Installation"), before operating this machine. Improper installation may cause a fire, electric shock, injury, breakdown, or other inconvenience.
- The warning label indicates important safety precautions. Observe the following:
 - The warning labels attached to this machine should be read well, therefore, you must take care the appropriate place to be installed and appropriate illumination and the soils on them. Do not let the warning label get hidden by another game machine or other object.
 - Do not detach or modify the warning label.
 - If the warning label gets considerably dirty or damaged, replace it with a new one. To order a new warning label, contact your dealer.

7-1 Pre-service check

Before beginning your service, check the items described below. If any trouble is found, take appropriate actions according to P-48, 8-2 "Troubleshooting."

7-1-1 Appearance check



WARNING

- Check the points listed below before operating this machine. These checks are required to avoid accidents and injury.
 - Is the warning label legible enough?
 - Are all level adjusters fixed?
 - Is there a sufficient clearance around this machine? (See P-11, 5-1 "Conditions for Installation.")
 - Is the gun tube fastened at both ends? Is it damage-free?
 - Are the gun screws fastened?
 - Are the tower Assy and cabinet Assy fastened together?
 - Are the pedal Assy and tower Assy fastened together?

7-1-2 Operation check

- 1 Checking the sound
- 2 Checking the fluorescent lamps
- 3 Checking the image

To check the items listed below, press the service switch and play a game. (See P-29, 7-3-2 "Adjustment Switches.")

- 4 Checking the gun for response
- 5 Checking the pedal effect

7-1-3 Periodic check

Clean the gun lens every day to keep it precise.

- Wipe off dirt gently with a soft cloth.

7-2 How to play

This machine provides gun shooting games where players use a pedal to hide behind an object to avoid an enemy attack, then get out from behind the object with their own timing to attack the enemy.

7-2-1 How to control

1. Step on the pedal = attack position: At this position, you can shoot the enemy. You are also subject to an enemy attack.
2. Release the pedal = defence position: At this position, you are hidden behind an object. You are not subject to an enemy attack. Releasing the pedal recharges the gun.

7-2-2 Modes

1. Link play mode: This mode is for two-player cooperative plays. An additional player can join the game after it has started.
2. Solo play mode: This mode is for single-player plays. No one can join the game once it has started.

* Modes are selected on the Mode Selection Screen immediately after you insert a coin.

7-2-3 Rules

1. Every time you get an enemy attack, you lose a life. You also lose a life when your remaining time reaches zero. The remaining time is recovered when you have destroyed all your enemies appeared or you have received an enemy attack. The game is over when you have zero lives left.
2. A player's achievement is assessed by score. The higher the score, the higher achievement.

Demonstration video clips between games can be skipped by aiming and shooting the gun at the screen.

7-3 Adjustment

7-3-1 Turn on the power switch.

When you are through with P-11, 5. "Installation," turn on the power switch at the bottom left of the rear of the body Assy.

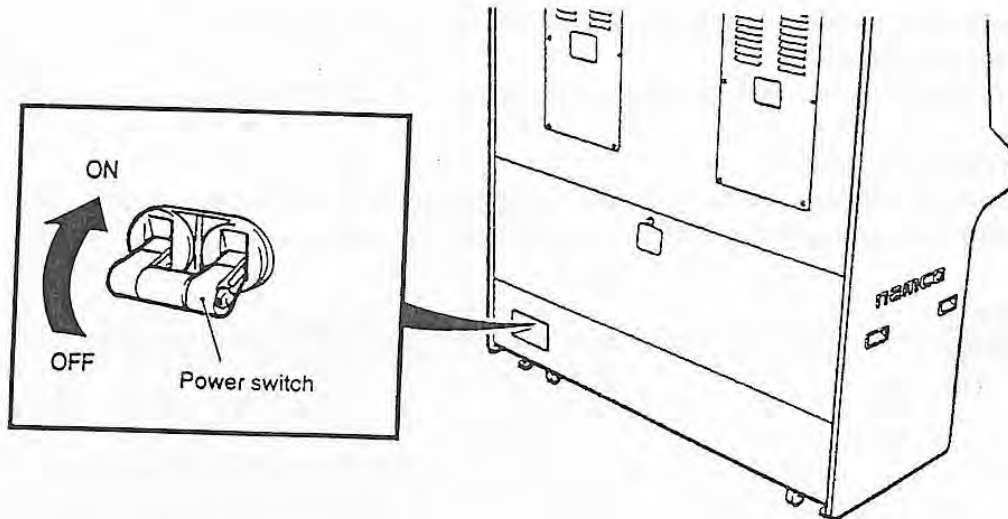

7-3-2 Adjustment switches

Open the service door of the coin Assy, and you will find the adjustment switches.

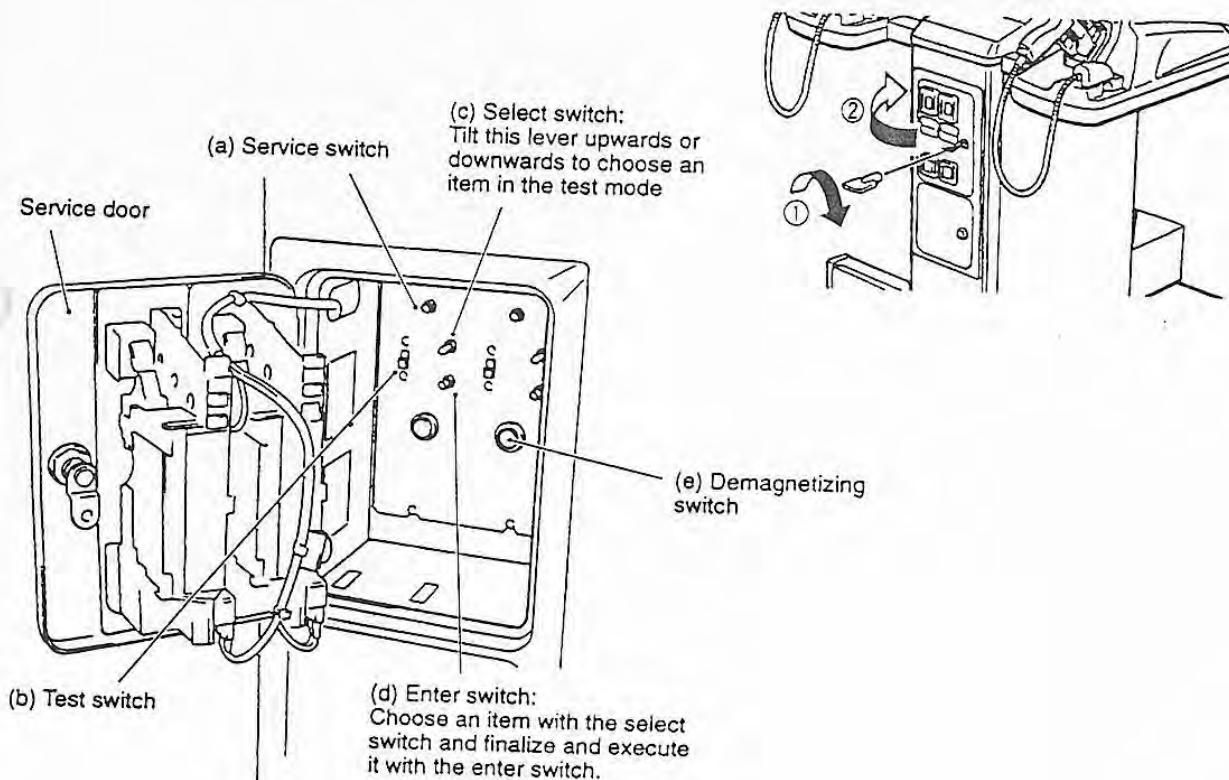

- (a) Service switch (red)
Press this switch to increase the credit count without activating the coin counter.
- (b) Test switch
Turn this switch on to enter the test mode.
In the test mode, you can change game fees and other parameters and conduct various tests.
(See P-31, 7-4 "Test Mode.")
- (c) Select switch
Tilt this switch upwards or downwards to choose an item in the test mode.
- (d) Enter switch (green)
After choosing an item with the select switch, press this switch to finalize and execute that item.
- (e) Demagnetizing switch
If the monitor displays uneven coloring due to geomagnetism caused by the machines layout or building conditions, press this switch to demagnetize the monitor.



- Unless slowly and securely pressed, the service switch may not get activated.

7-4 Test mode

7-4-1 Description of the menu screen

- 1 Unlock the coin door with a key furnished with this machine to open the door, then turn on the test switch. The screen displays MENU.

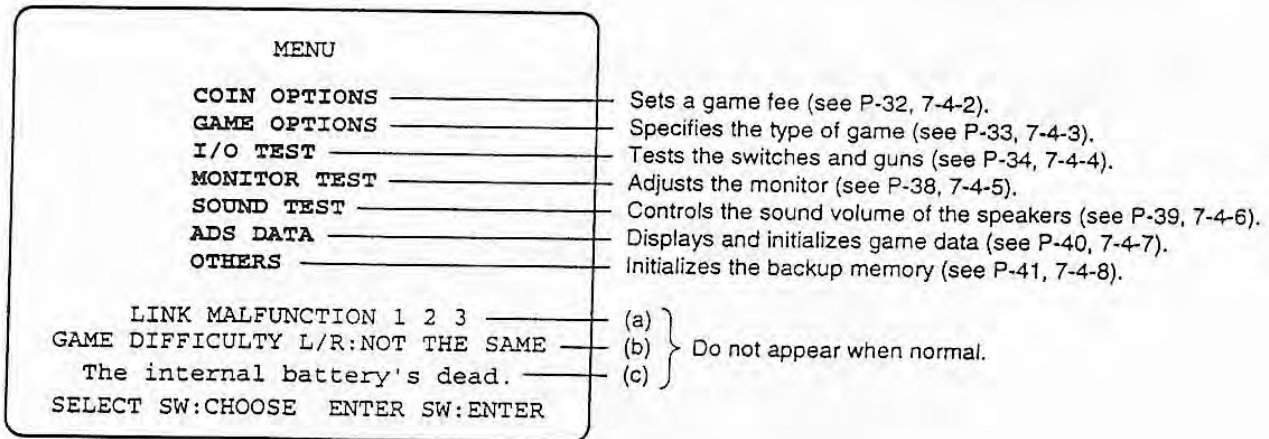

Menu screen

- 2 Tilt the select switch upwards or downwards to choose an item. The selected option blinks.
- 3 Press the enter switch to determine an option.
- 4 When the adjustment is over, select EXIT and press the enter switch. You go back to the MENU screen.
- 5 When all adjustments are over, turn off the test switch. You then go back to the game screen.

If this machine breaks down or is in other trouble, (a), (b), and (c) display error messages.

(a) Error messages related to link play

- A message appears when the link play is defective. The game does not function normally while the error is on. The number at the right of the message represents the type of error.
- When "1" or "2" is displayed, a board (either the MAIN (1) or the MSPM game PC board) may be defective. (See P-61, 8-3-1 (5) "Exchanging Game PC Boards.") Contact your dealer.
- If "3" is displayed, the software version used on the right-hand board and that on the left-hand one do not match. Contact your dealer.

(b) Error messages related to difficulty setting

- A message appears when the difficulty setting for the test mode on the right-hand side and that for the left-hand one do not match. The game does not function normally while the error is on. Enter the GAME OPTIONS in the right- and left-hand test modes and make the difficulty settings match.

(c) Low-battery display

- When the battery level is low, a message appears. You must have the battery on the MAIN (1) game PC board replaced with a new one. Contact your dealer.

7-4-2 Setting a game fee and free play (COIN OPTIONS)

Here you set a game fee and free play parameters.

- 1 While on the MENU screen, select COIN OPTIONS and press the enter switch. The COIN OPTIONS screen will appear.

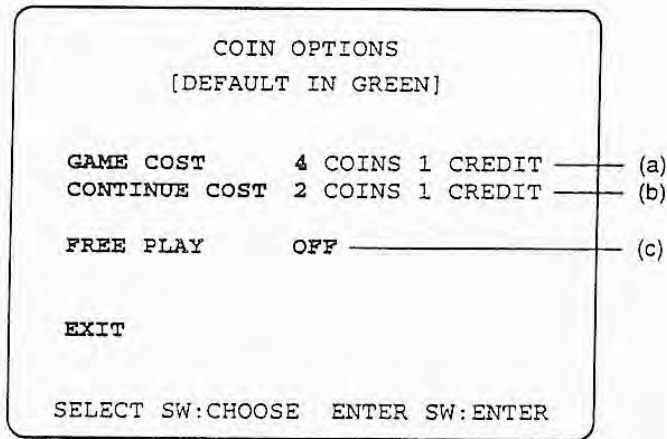

COIN OPTIONS screen

Option	Description	Factory setting
(a) Setting a game fee	Coins required for one game: 1-9 coins	—
(b) Setting a continue play fee	Coins required for continue play: 1-9 coins	—
(c) Setting free plays	OFF (No) ON (Yes)	OFF

COIN OPTIONS settings table

- 2 Use the select switch to choose the option you wish to change. The selected option blinks.
- 3 Press the enter switch and determine an option you wish to change.
- 4 After determining the option, use the select switch to change the contents of the option.
- 5 After changing the contents of the option, press the select switch to go back to option selection.
- 6 Select EXIT and press the enter switch to go back to the MENU screen.

* When the free play setting is on, stepping on the pedal starts a game.

7-4-3 Setting the type of game (GAME OPTIONS)

Here you set the type of game.

- 1 While on the MENU screen, select GAME OPTIONS and press the enter switch. The GAME OPTIONS screen will then appear.

GAME OPTIONS
[DEFAULT IN GREEN]

PLAYER'S LIFE	4				
DIFFICULTY	C (MEDIUM)				(a)
ATTRACT SOUND	ON				(b)
HI-SCORE INIT	NO				(c)
	YES				(d)

EXIT

SELECT SW: CHOOSE ENTER SW: ENTER

GAME OPTIONS screen

Option	Description	Factory setting
(a) Setting player lives	Lives of the player at the start of the game 1 to 9	4
(b) Difficulty*	A (VERY EASY) B (EASY) C (MEDIUM) D (HARD) E (VERY HARD)	C (MEDIUM)
(c) Setting the sound volume at the attract mode	ON (with sound) OFF (without sound)	ON
(d) Initializing the high score	NO (not to initialize) YES (initialize)	NO

Table of GAME OPTIONS settings

- 2 With the select switch, choose an option which you wish to change. The selected option blinks.
- 3 Press the enter switch to determine an option you wish to change.
- 4 After determining the option, use the select switch to change the contents of the option.
- 5 After changing the contents of the option, press the enter switch to go back to option selection.
- 6 Select EXIT and press the enter switch to go back to the MENU screen.

* The game will not function normally unless the difficulty setting in (b) in the left-hand mode matches that for the right-hand mode. Always match the difficulty settings for the left- and right-hand modes.

7-4-4 I/O tests for switches (I/O TEST)

Conduct I/O tests on the switches.

- 1 While on the MENU screen, select I/O TEST and press the enter switch. The I/O TEST screen will then appear.

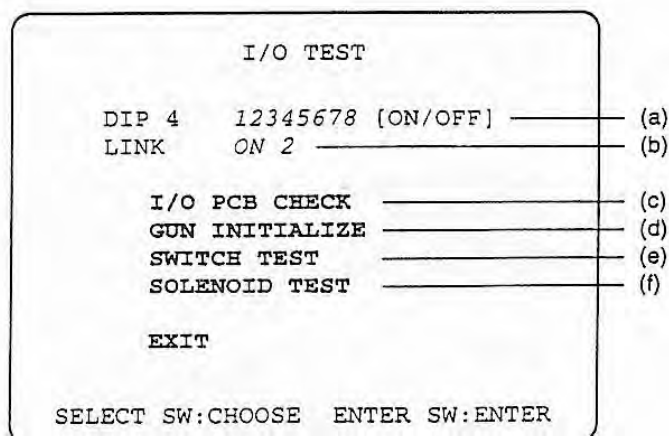

I/O TEST screen

- 2 With the select switch, choose an option you wish to execute. The selected option blinks.
- 3 Press the enter switch to go back to the test screen for the blinking option.
- 4 Select EXIT and press the enter switch to go back to the MENU screen.

(a) Status of the DIP switches

- This displays the status of the DIP switches on the game PC board. The switches of the numbers in red are on. (They are all factory-configured to be off.)
- All of them are normally used in the off status.

(b) Communication check

- This represents the communications status.

Display	Communication status
LINK ON 2	When normal
LINK OFF ※	When no data is received
LINK NG ※	When unidentified data is received

Table of communication check settings

- ※ If the screen displays LINK OFF or LINK NG, the game will not function normally. The board (game PC board) may be defective. Contact your dealer.
- When this machine is to be run with one of the game PC boards for repair or other purposes, it is to be in the solo play mode. (See P-28, 7-2-2 "Modes.")

(c) I/O PCB check

This function displays a screen for checking the I/O board.

```

                I/O TEST
DIP 4   12345678 [ON/OFF]
LINK   ON 2
I/O PCB CHECK
Master TX 3536 namco ltd.
Time Crisis 2; Ver1.00;JPN

I/O PCB Connect OK namco ltd.
TSS-I/O;Ver2.02;JPN,GUN-EXTENTION

EXIT
SELECT SW:CHOOSE  ENTER SW:ENTER
```

I/O PCB check screen

Press the enter switch to go back to the I/O TEST screen.

(d) GUN INITIALIZE

This function sets the aiming of the gun. See P-42, 7-5 "Aiming the Gun (GUN INITIALIZE)."

(e) SWITCH TEST

This function tests the various switches.

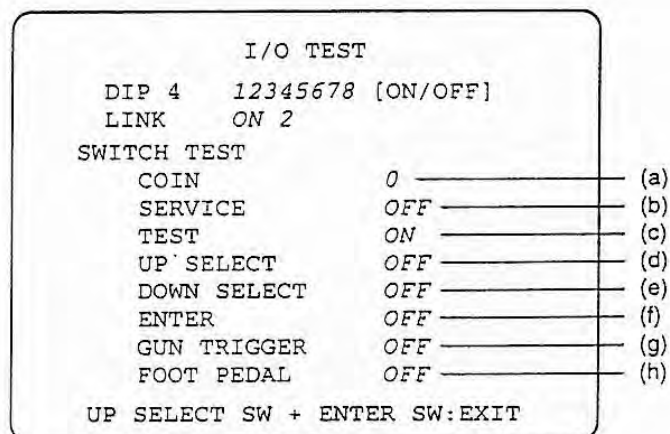

Switch test screen

- 5** The switch test screen displays the status of the switches.
- 6** Operating the switches toggles the corresponding settings.
 - (a) The count rises every time the coin switch is activated.
 - (b) Turns on when the service switch is pressed.
 - (c) Turns on when the test switch is turned on.
 - (d) Turns on when the select switch is tilted upwards.
 - (e) Turns on when the select switch is tilted downwards.
 - (f) Turns on when the enter switch is pressed.
 - (g) Turns on when the gun trigger is pulled.
 - (h) Turns on when the pedal is stepped on.
- 7** Press the enter switch with the select switch tilted up, and you will go back to the I/O TEST screen.

(f) SOLENOID TEST

This function tests the blow-back mechanism of the gun.

```

                                I/O TEST
                                DIP 4  12345678 [ON/OFF]
                                LINK   ON 2
                                SOLENOID TEST
                                PULL GUN TRIGGER TO ACTION
                                EXIT
                                SELECT SW:CHOOSE  ENTER SW:ENTER

```

Solenoid test screen

- 8** Pull the gun trigger to activate the gun's blow-back mechanism.
- 9** Press the enter switch to go back to the I/O TEST screen.

7-4-5 MONITOR TEST

The MONITOR TEST performs various adjustments on the monitor.
(See P-55, 8-3-1 (3) "Adjusting the monitor.")

- 1 While on the MENU screen, select MONITOR TEST and press the enter switch. The MONITOR TEST screen will then appear.

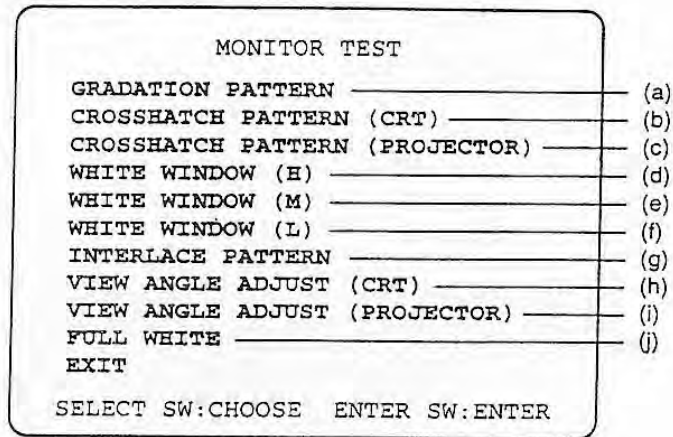

MONITOR TEST screen

- 2 With the select switch, choose an option. The selected option will blink.
- 3 Press the enter switch to display the corresponding pattern. To get out of the pattern screen, press the enter switch again.
 - (a) Displays a gradation pattern.
 - (b) Displays a crosshatch pattern for CRT monitor. (This is not used for projectors.)
 - (c) Displays a crosshatch pattern for projectors. (This not used for CRT monitors.)
 - (d) Displays the white window (H, or high).
 - (e) Displays the white window (M, or medium).
 - (f) Displays the white window (L, or low).
 - (g) Displays an interlace pattern.
 - (h) Displays an adjustment screen for CRT monitors. (This is not used for projectors.)
 - (i) Displays an adjustment screen for projectors. (This is not used for CRT monitors.)
 - (j) Displays white all over the screen.
- 4 Select EXIT and press the enter switch to go back to the MENU screen.

7-4-6 SOUND TEST

The SOUND TEST function adjusts the sound volume and performs a stereo check and related operations.

- 1 While on the MENU screen, select SOUND TEST and press the enter switch. The SOUND TEST screen will then appear.

SOUND TEST
[DEFAULT IN GREEN]

VOLUME FRONT L SP (0-64) 40 — (a)
FRONT R SP (0-64) 40 — (b)

REQUEST SONG NO. 000 — (c)

MESSAGE: _____ (d)

EXIT

SELECT SW: CHOOSE ENTER SW: ENTER
SERVICE SW: REQUEST ON/OFF

SOUND TEST screen

- 2 With the select switch, select an option you wish to change. The selected option will blink.
- 3 Specify (a), (b), and (c) and press the enter switch to blink the value you have specified. Tilt the select switch upwards and downwards to adjust the value.

Option	Description	Factory setting
(a) Setting the sound volume of the left-hand speaker	00 (minimum) to 64 (maximum)	40
(b) Setting the sound volume of the right-hand speaker	00 (minimum) to 64 (maximum)	40
(c) Selecting a music number	Selecting a music number and sound effects	000

Table of sound test settings

- 4 In the case of (c), each press of the enter switch shifts adjustments from digit to digit. With the select switch, adjust the value at each digit to set the number. Press the service switch to sound the music number or sound effects that corresponds to the number selected.
- * 000 represents no sound, while 001 represents a stereo test. Selecting 001 and pressing the service switch produces sound in the following order: left-hand speaker, right-hand speaker, and left- and right-hand speakers. At the same time, (d) displays LEFT, RIGHT, and CENTER accordingly.
- 5 Select EXIT and press the enter switch to go back to the MENU screen.

7-4-7 Displaying and initializing game data (ADS DATA)

This function displays various game data.

- 1** While on the MENU screen, select ADS DATA and press the enter switch. The ADS DATA will then appear.
- 2** Power-off does not cause data to be lost, unless you execute ADS INITIALIZE or BACKUP MEMORY INITIALIZE in OTHERS.
- 3** After the check, select EXIT and press the enter switch. You will then go back to the MENU screen.

7-4-8 OTHERS

This function initializes backup memory and conducts related operations.

- 1 While on the MENU screen, choose OTHERS and press the enter switch. The OTHERS screen will then appear.

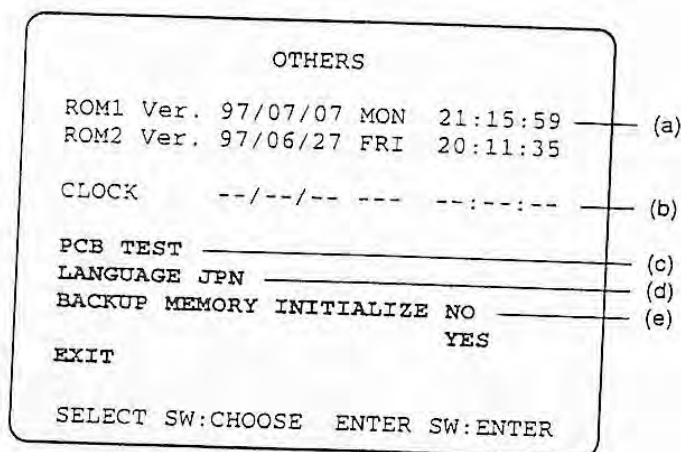

OTHERS screen

- 2 With the select switch, choose an option you wish to execute. The selected option will blink.
- (a) Displays the software version.
 - (b) Not used in this machine.
 - (c) Used to test the PC board (not used in running).
 - (d) Selects a language used in the attract mode.
 - English : ENG
 - German : GER
 - French : FRA
 - Spanish : SPA
 - Portuguese : POR
 - Italian : ITA
 - (e) Initializes backup memory. Select YES and press the enter switch to clear all settings for GUN INITIALIZE, high score, and other parameters and to go back to the factory settings.

※ The game will not proceed normally unless the software version (a) in the test mode of the right-hand side does not match that on the left-hand side. Contact your dealer.

- 3 Press the enter switch to execute the blinking option.
- 4 Select EXIT and press the enter switch to go back to the MENU screen.

7-5 Setting the gun aiming (GUN INITIALIZE)

This function sets the gun aiming.

- 1 While on the I/O TEST screen, select GUN INITIALIZE and press the enter switch. (Or turn on the test switch while holding down the service switch.) The GUN INITIALIZE screen (Fig. 1) will then appear.

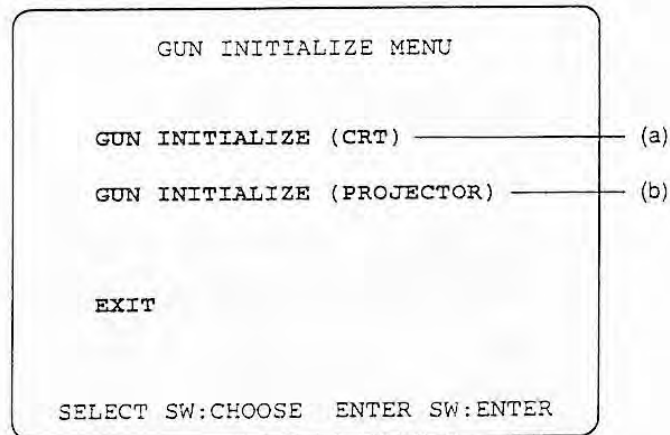

Fig.1 GUN INITIALIZE MENU screen

- 2 With the select switch, choose an option you wish to execute.
 - (a) Choose this option because this machine is of the 29" monitor type.
 - (b) Used for projector types. (Not used with this machine.)The selected option will blink.
 - 3 Press the enter switch to go to the screen for the blinking option.
 - 4 Select EXIT and press the enter switch to go back to the I/O TEST screen.
- ※ Turn off the test switch to go back to the game screen.

GUN INITIALIZE (CRT)

This function sets the gun aiming (Fig. 2-1).

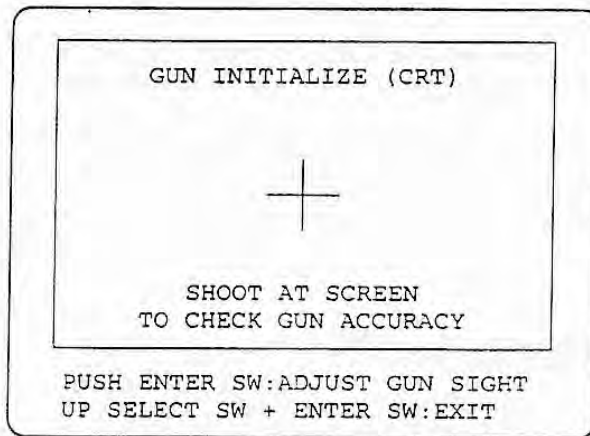

Fig. 2-1 GUN INITIALIZE (CRT) screen 1

- 1 The screen indicated in Fig. 2-1 allows you to check if the gun has the correct aim. Shoot the gun at the screen and the screen will display bullet impact where a bullet has reached. Check if the bullet impact is displayed at the point at which you aimed.
- 2 While in the screen indicated in Fig. 2-1, press the enter switch (or step on the pedal) to go to the screen illustrated in Fig. 2-2.
- 3 Press the enter switch with the select switch tilted up to go back to the GUN INITIALIZE MENU.

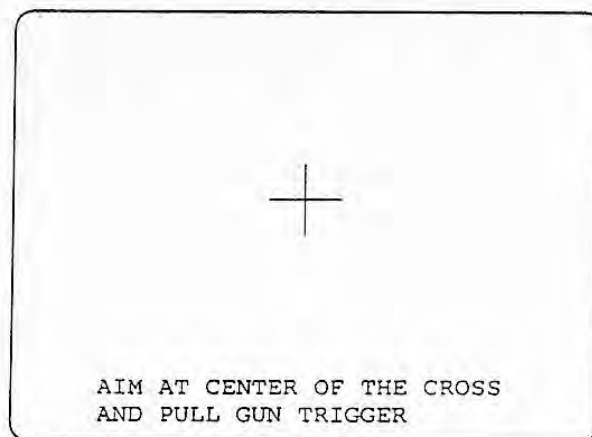

Fig. 2-2 GUN INITIALIZE (CRT) screen 2

- 4 While on the screen indicated in Fig. 2-2, aim the gun at the center of the cross (+) and shoot. This will initialize the gun aiming. After shooting, it will go back to the screen indicated in Fig. 2-1.
- 5 While on the screen indicated in Fig. 2-1, check if you can shoot properly at every point and corner inside the frame. If the gun aiming is not good, press the enter switch (or step on the pedal) to go back to the screen indicated in Fig. 2-2. Then aim the gun again at the center of the cross and shoot to adjust the aiming again.

* Turn off the test switch to go back to the game screen.

8. MAINTENANCE



WARNING

- Before performing maintenance (such as troubleshooting and repairs), always turn off the power switch to prevent service people and other persons around them from getting an electric shock, accident, or injury.
- Some parts in the projector retain high heat and voltage after power-off. These may give you an electric shock or get you burned. Therefore take enough care not to touch any of them.

8-1 Maintenance and inspection



- Do not forget to conduct periodic inspection.

8-1-1 Greasing the plunger of the pedal Assy

- To be conducted by a technician only -

NOTICE ● Grease the plunger every six months.

- 1 Loosen the four flange sockets (M6 × 20) on the cabinet body side.
- 2 Remove the four flange sockets (M5 × 12) on the pedal Assy, then remove the connector. Then remove the pedal Assy.

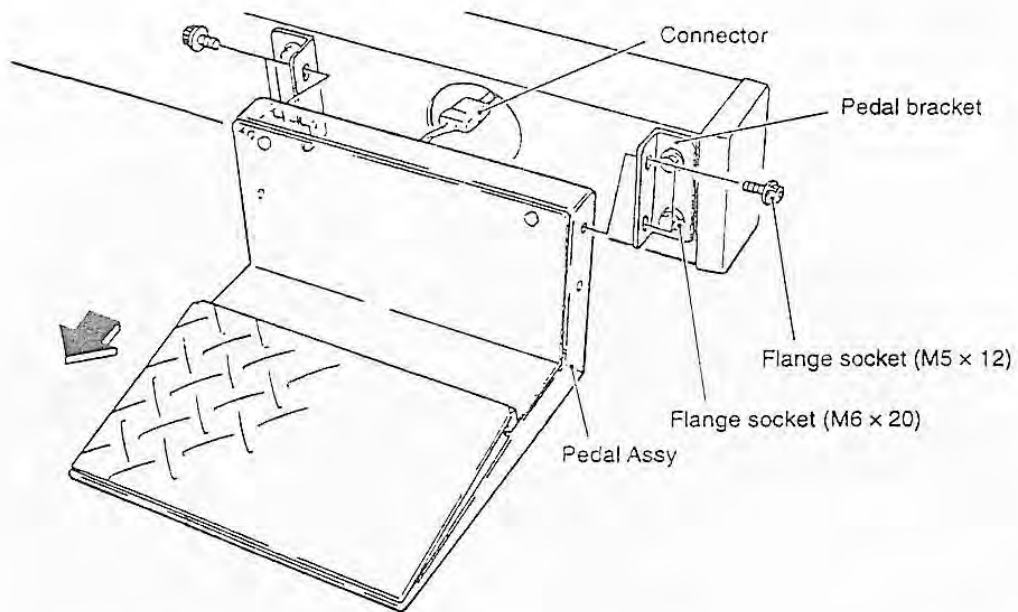

- 3 Remove the four torque bolts (M5 × 12), then detach the cover.

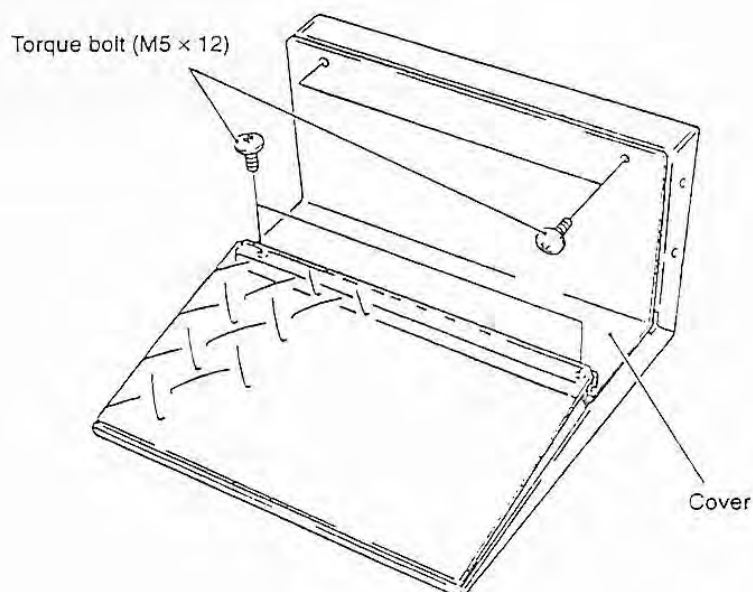

8. MAINTENANCE

- 4 Remove the two dished-end washer nuts (M4) and remove the microswitch.
- 5 Remove the four dished-end washer nuts (M4) from the holder, then pull up the holder while pulling the plunger.
- 6 Wipe off the grease from the pedal.
- 7 Grease the plate and the spherical part of the plunger.
 - Specified grease brand: Albania No. 2 (Showa Shell)

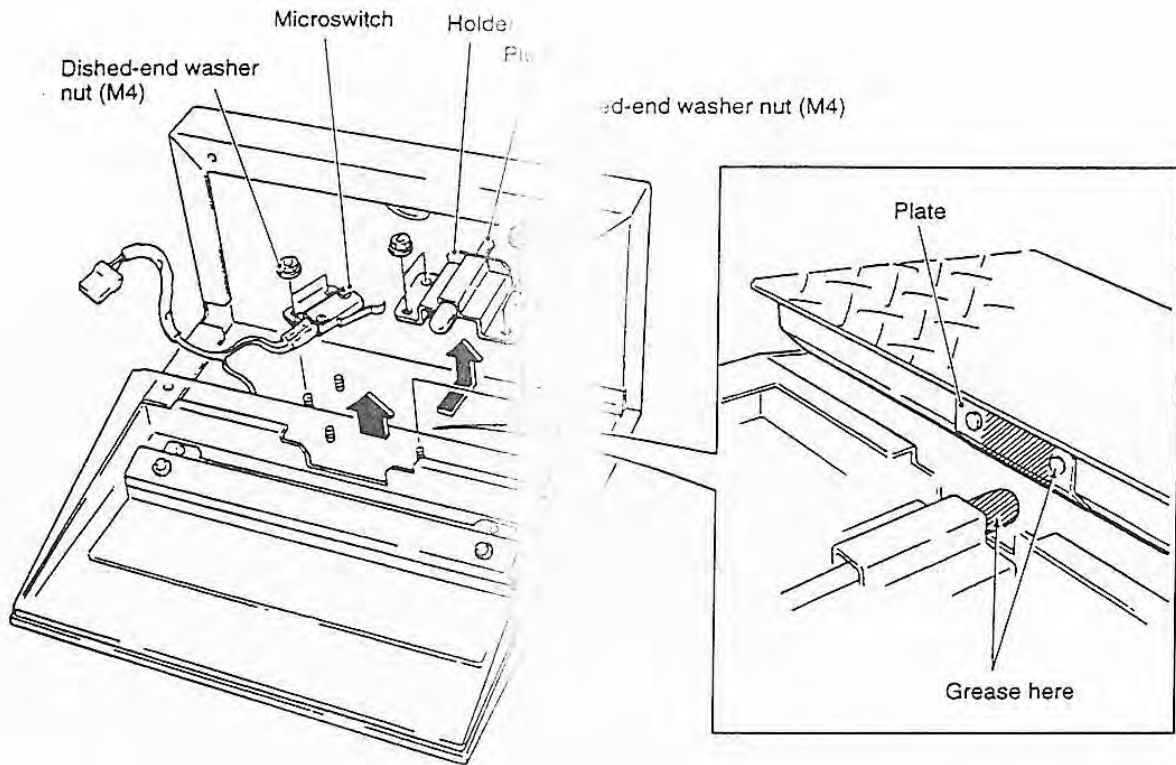

- 8 Assemble the pedal Assy in reverse order. For adjusting the microswitch, see P-66, 8-3-4 (1) "Replacing the Microswitch."

8-1-2 Checking the plunger of the pedal assembly for wear and tear

- 1 Remove the four torque bolts (M5 × 12), then detach the cover.

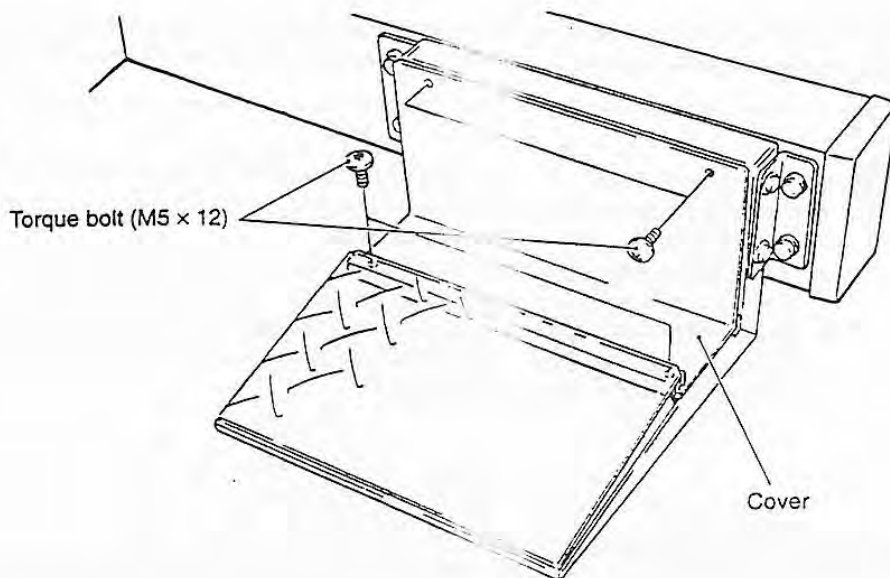

- 2 Press the pedal with a hand and make a visual check to see if the plunger is pressing the microswitch.

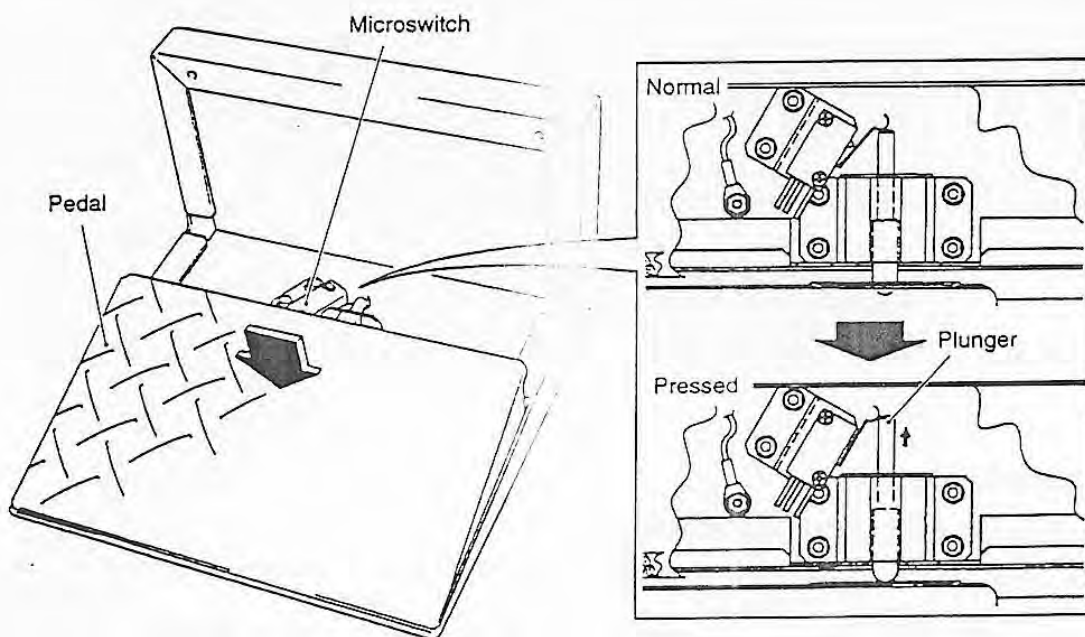

- 3 If the plunger is worn and not pressing the microswitch, replace the plunger with a new one. (See P-67, 8-3-4 (2) "Replacing the Plunger")

8-2 Troubleshooting



WARNING

- Before carrying out this task, always turn off the power switch to prevent workers and people around from getting an electric shock, accident, or injury and to protect the electric circuit from damage.

NOTICE

- In the case of trouble, first check that all connectors are firmly connected.
- If none of the cases described below applies to the trouble or if any actions do not seem to solve the problem, contact your dealer.
- In repairing the game PC board, never conduct a continuity test with a tester or anything similar. This might destroy the ICs due to the inner voltage of the tester.
- To send any component for repairs, package it securely. When sending the game PC board, in particular, wrap it with a sponge, air cap, or something similar and put it into a corrugated carton to avoid external forces.

8-2-1 General

– To be conducted by a technician only –

Symptom	Cause	Action	See page
The machine's behavior is not stable. It malfunctions.	The supply voltage is not within the rated voltage range.	Disconnect the large-capacity electric equipment on the same line (such as an air-conditioner and large video machines) to secure a specified supply voltage.	—
This machine powers off when you do not expect it.	The circuit protector is activated and the power switch is off.	Turn the power switch back on. If the circuit protector gets activated over and over again, this machine must be defective. Contact your dealer.	Page 28
The speakers do not sound.	The sound volume is too low.	Re-adjust the sound volume.	Page 39
	The connector connecting the signboard Assy to the cabinet Assy is loose.	Connect the connector.	Page 14

8-2-2 Cabinet Assy

– To be conducted by a technician only –

Symptom	Cause	Action	See page
The monitor does not display pictures.	The connectors connecting the monitor to the rack Assy are loose.	Open the rear cover or maintenance panel, then connect the connectors.	Page 50-53 Page 60

8-2-3 Signboard Assy

- To be conducted by a technician only -

Symptom	Cause	Action	See page
The fluorescent lamp does not light up.	The connector is loose.	Connect the connector.	Page 14
	The fluorescent lamp is dead.	Replace the fluorescent lamp with a new one.	Page 63
	The glow lamp is dead.	Replace the glow lamp with a new one.	Page 63

8-2-4 Tower Assy

- To be conducted by a technician only -

Symptom	Cause	Action	See page
The gun Assy does not work.	The connector is loose.	Connect the connector firmly.	Page 68
	The I/O PC board is defective.	Replace the I/O PC board with a new one.	Page 64

8-2-5 Pedal Assy

- To be conducted by a technician only -

Symptom	Cause	Action	See page
The pedal does not work.	The microswitch is out of order.	Replace the microswitch with a new one.	Page 66
	The connector is loose.	Connect the connector.	Page 17
	The plunger is worn.	Replace the plunger with a new one.	Page 67

8-2-6 Gun Assy

- To be conducted by a technician only -

Symptom	Cause	Action	See page
The gun does not blow back.	The connector is loose.	Connect the connector.	Page 68
	The microswitch is out of order.	Replace the microswitch with a new one.	Page 72
	The solenoid is worn.	Replace the solenoid with a new one.	Page 71 .
Bullet impact is poor.	The lens is soiled.	Clean the lens.	Page 70
	The gun initialize is out of focus.	Re-initialize the gun.	Page 42

8-3 Disassembling, reassembling and replacing the Assys and parts

8-3-1 Cabinet Assy

– To be conducted by a technician only –

(1) Detaching and reattaching the rear cover



WARNING

- Before carrying out this task, always turn off the power switch to prevent workers and people around them from getting an electric shock, accident, or injury and to protect the electric circuit from damage.

- 1 Remove the two Phillips truss screws (M5 × 35), release the lock at the top middle, and open the rear cover.

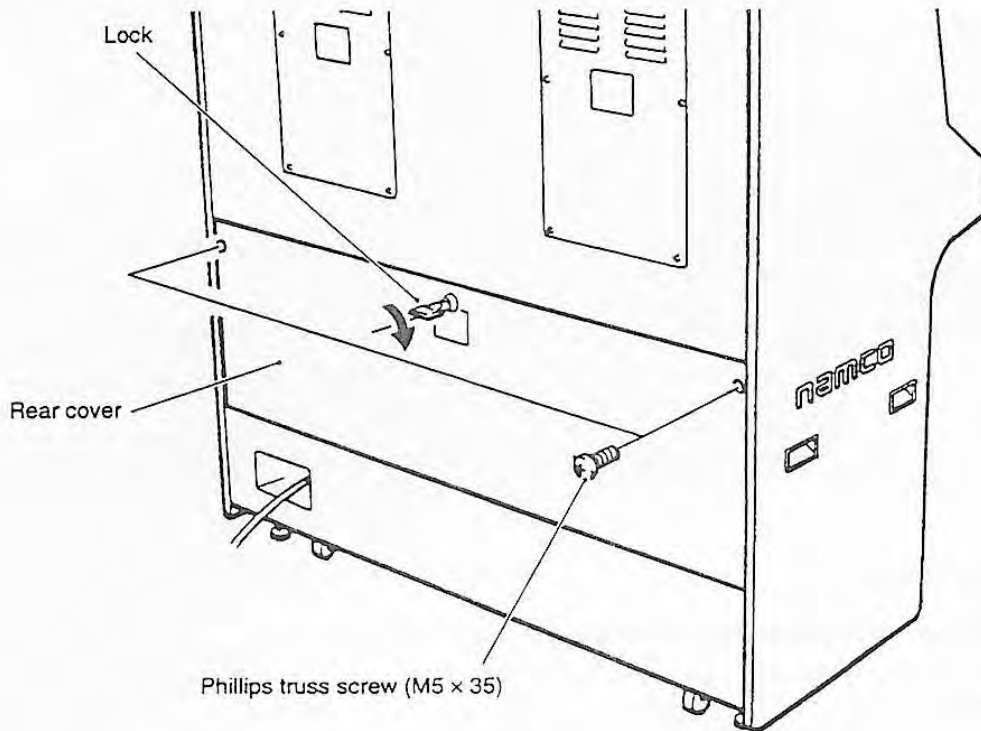

- 2 Reattach the components in reverse order.

(2) Replacing the monitor with a new one

 represents something that must not be touched.

 **DANGER**

- Before carrying out this task, always turn off the power switch to prevent workers and people around them from getting an electric shock, accident, or injury and to protect the electric circuit from damage.
- Some parts in the monitor have voltages of more than 20,000 volts and might give you an electric shock. Therefore do not touch anything inside the monitor.
- The anode cap, anode lead, and flyback transformer retain high voltage after power-off. Never touch any of them, because it might give you an electric shock.
- Do not touch anything other than the stay, angle, and monitor CRT surface when replacing the monitor with a new one.

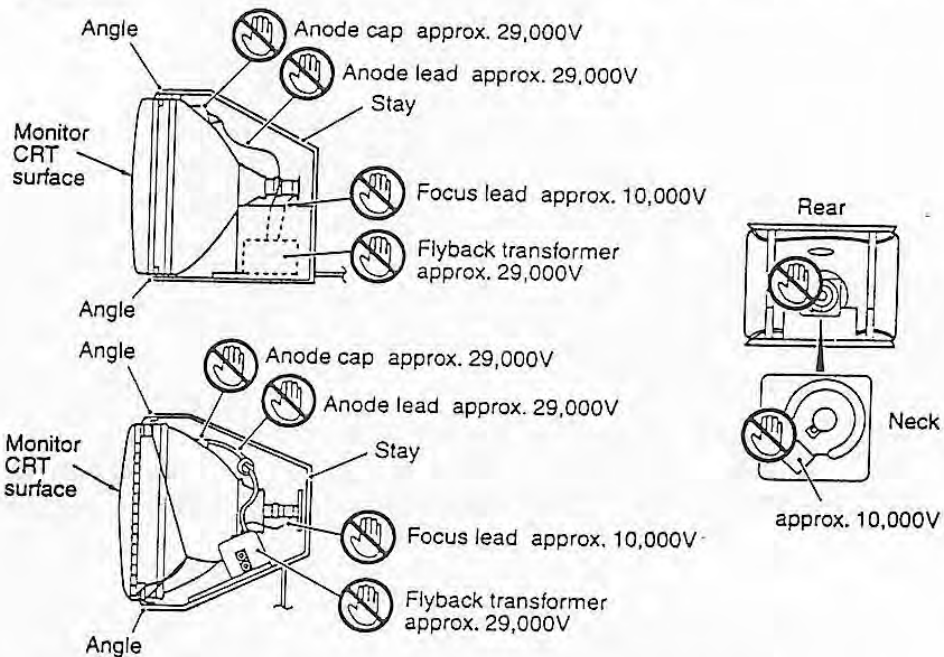

- The monitor circuitry is divided into a primary and a secondary, which are electrically insulated from each other. Do not touch the primary. Do not touch the primary and secondary at the same time (thus short-circuiting them). This might cause an electric shock or breakdown, thus being dangerous.
- Secondary (chassis sheet panel, CRT, etc.)
- Primary (main PCB)

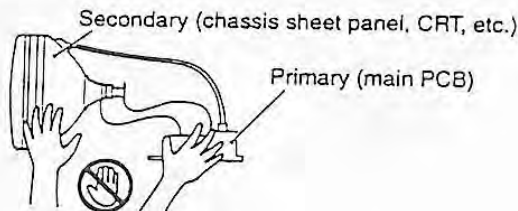

 **WARNING**

- If solder dust, paper dust, or other foreign matter is found inside the monitor, turn off the power switch and contact your dealer, in order to avoid fires and breakdowns.
- If the monitor shows any disorder, turn off the power switch immediately and contact your dealer.
- The monitor weighs about 40kg. This work must be conducted by at least two workers.

- 1 Remove the pedal Assy and tower Assy. (See P-21, 6-2-1 "Dividing" — To be conducted by a technician only.)
- 2 Of the torque bolts (M5 × 12) at the back of the cabinet Assy, loosen the bottom two and detach the top four, thus removing the maintenance panel.

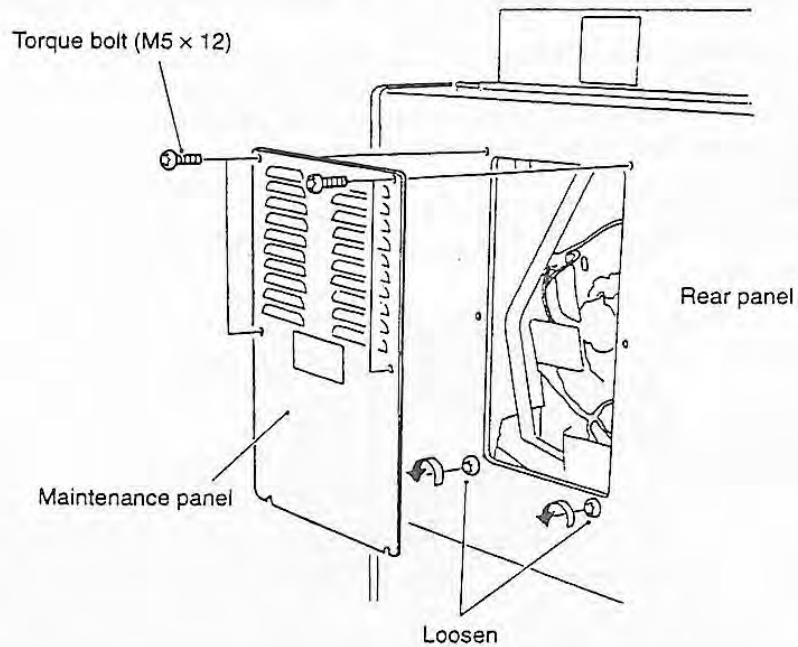

- 3 Remove the two connectors from the monitor.
This machine may come with a monitor having a differently-shaped frame depending on the time of production. Check which type of monitor is used, Nanao-made or Toei-made.

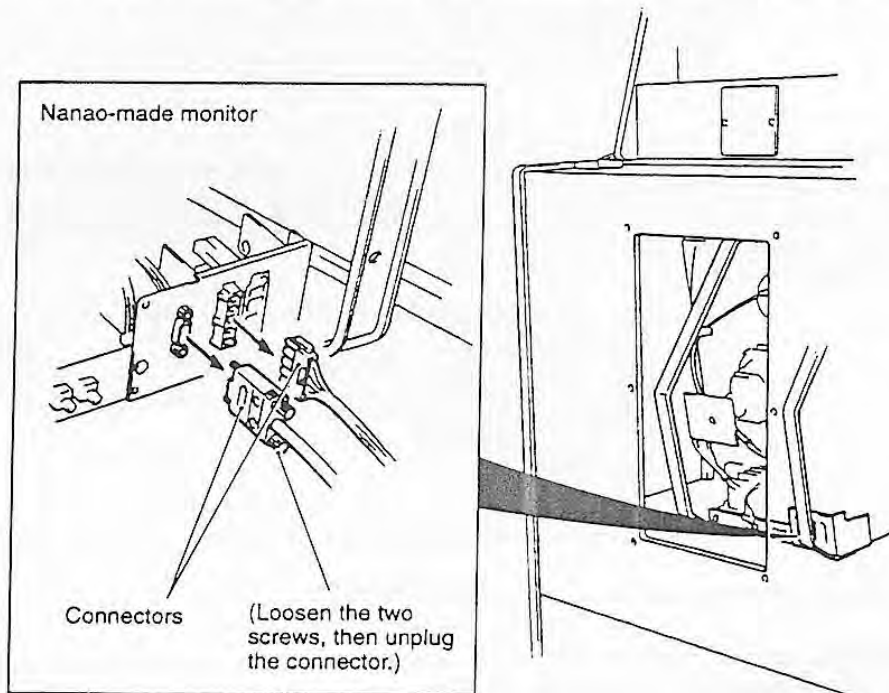

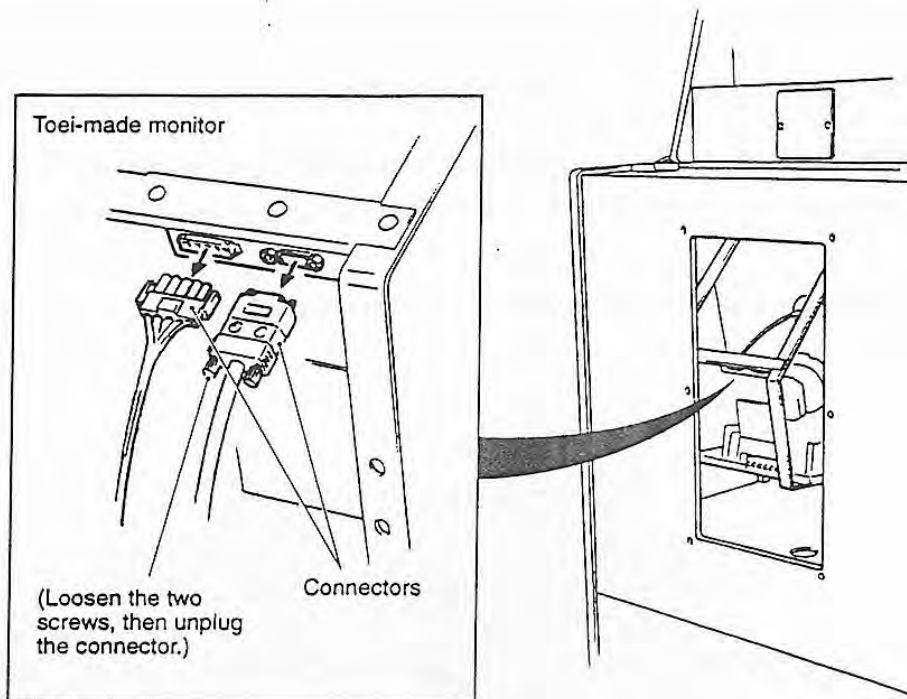

- 4 Remove the eight torque bolts (M5 × 20), then detach the monitor mask.

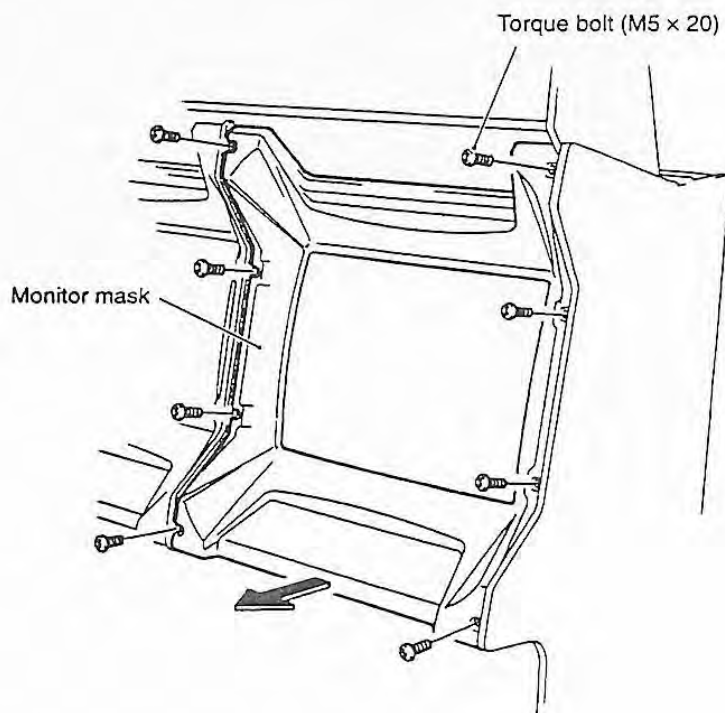

- 5 Remove the four Phillips hexagon bolts (with flat and spring washers) (M8 × 25) and four washers.



WARNING

- The monitor weighs about 40kg. This work must be conducted by at least two workers.

- 6 Tilt the top of the monitor forwards slowly, then detach the monitor.

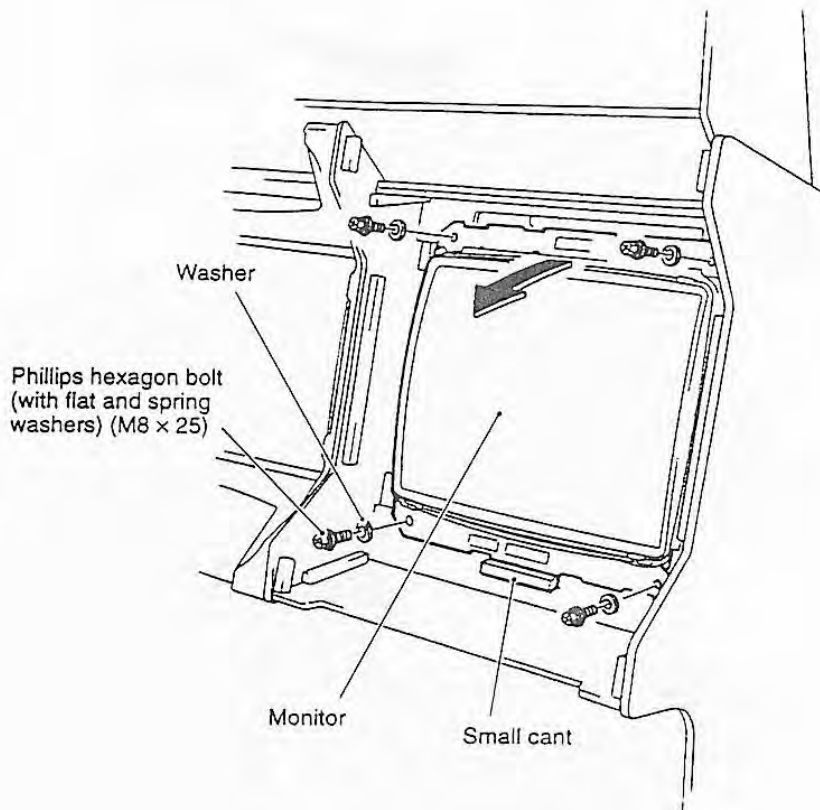

- 7 In re-installation, follow reverse order.

(3) Adjusting the monitor

 represents something that must not be touched.

! DANGER

- The monitor is adjusted while powered on. This may therefore give you an electric shock, accident, or injury. Do not touch anything other than the parts specified in the adjustment procedure.
- Some parts in the monitor have voltages of more than 20,000 volts. Do not touch anything inside the monitor, because it may give you an electric shock.

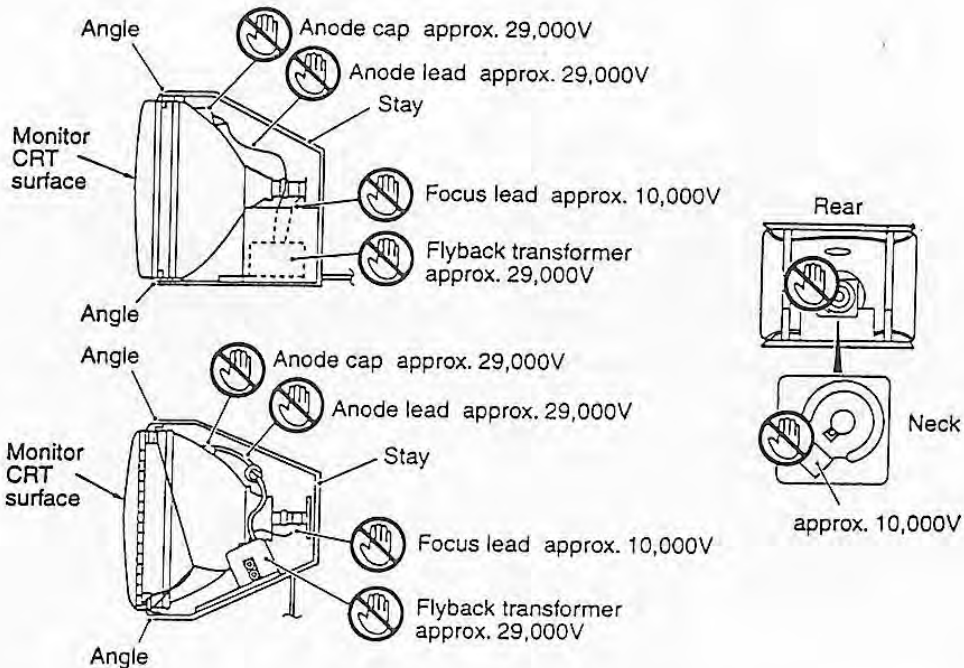

- The monitor circuitry is divided into a primary and a secondary, which are electrically insulated from each other. Do not touch the primary. Do not touch the primary and secondary at the same time (thus short-circuiting them). This might cause an electric shock or breakdown, thus being dangerous.

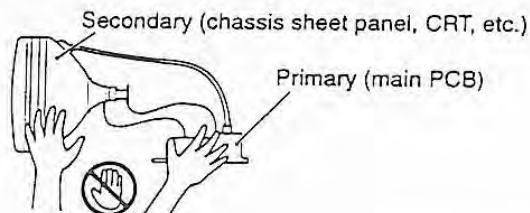
**! WARNING**

- If solder dust, paper dust, or other foreign matter is found inside the monitor, turn off the power switch and contact your dealer, in order to avoid fires and breakdowns.
- If the monitor shows any disorder, turn off the power switch immediately and contact your dealer.

NOTICE

- The monitor is factory-configured to its best condition. No readjustment is normally needed.

- 1 Detach the maintenance panel. (See P-51, 8-3-1 (2) "Replacing the Monitor with a New One.")
- 2 This machine may come with a monitor having a differently-shaped frame depending on the time of production. Check which type of monitor is used, Nanao-made or Toei-made.

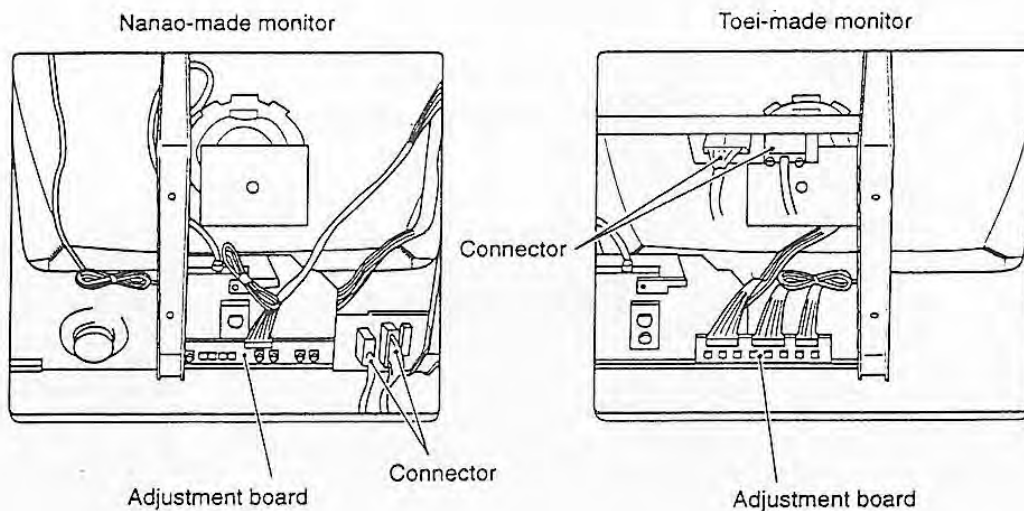

(a) Adjustment function

- 3 The adjustment boards for Nanao-made and Toei-made monitors are as illustrated below.

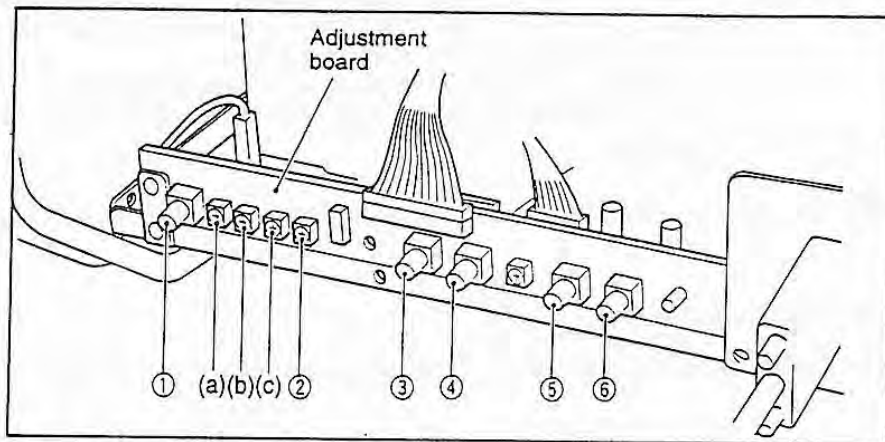

Fig. 1 Adjustment board for Nanao-made monitor

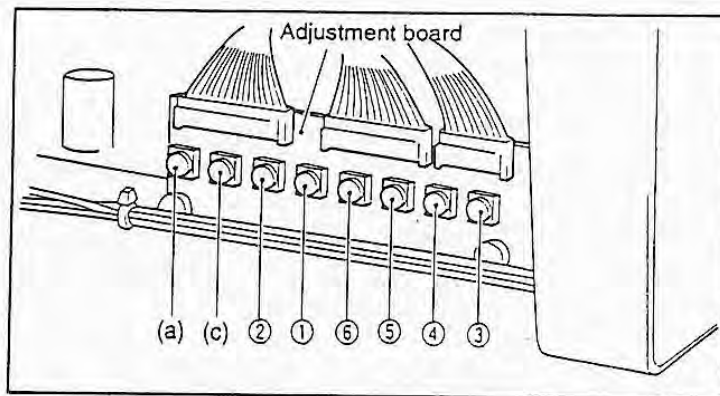

Fig. 2 Adjustment board for Toei-made monitor

- | | |
|---------------------------------------|---|
| ① CONTRAST (CONT.) (contrast) | : Adjusts picture contrast. |
| ② BRIGHT (luminance adjustment) | : Adjusts picture brightness. |
| ③ H.SIZE (horizontal size adjustment) | : Adjusts the horizontal size of the picture. |
| ④ H.POSI (horizontal positioning) | : Adjusts the horizontal display position of the picture. |
| ⑤ V.SIZE (vertical size adjustment) | : Adjusts the vertical size of the picture. |
| ⑥ V.POSI (vertical positioning) | : Adjusts the vertical display position of the picture. |

[Do not touch any of the following]

- | | |
|---|--------------------------------------|
| (a) R-GAIN (adjustment of red input gain) | : Adjusts the darkness of the red. |
| (b) G-GAIN (adjustment of green input gain) | : Adjusts the darkness of the green. |
| (c) B-GAIN (adjustment of blue input gain) | : Adjusts the darkness of the blue. |

NOTICE

- Do not touch (a), (b), or (c), because their adjustment requires special measuring equipment and expertise. If you touch any of them, you may find it impossible to get it back to its earlier position.

(b) Getting ready for adjustment**NOTICE**

- The display position and screen size on the monitor varies according to the direction of this machine. Perform all adjustments with this machine actually installed, whenever possible. If you have to move this machine for adjustment, adjust it with the machine oriented in the same direction as actually installed.
- In repositioning this machine frequently or performing adjustments at a place other than where this machine is supposed to be installed, perform adjustments with the monitor facing east.

- 4** Turn on the power switch, wait at least 30 minutes, then perform adjustments.

(c) Adjusting monitor display

- 5** Display the monitor test screen in the test mode. (See P-31, 7-4 "Test Mode.")

<Adjusting display size>

- 6** Two kinds of adjustment "display size adjustment" and "contrast adjustment" shall be performed.
- 7** The display size is adjusted as follows:
1. While in the monitor test screen, display VIEW ANGLE ADJUST (CRT) (Fig. 3 "Adjustment of Screen Size and Position"). (See P-38, 7-4-5 "MONITOR TEST.")
 2. Center the picture size. Adjust the **4** H.POSI (horizontal position) and **6** V.POSI (vertical position) alternately so that the center of the cross of the picture area comes approximately to the middle of the monitor surface.
 3. Adjust the horizontal size and position of the picture area
 - Adjust **3** H.SIZE (horizontal size) so that the screen end touches the border of the green and the white patterns at the center of the right/left side of the screen.
 - Perform fine adjustment on **3** and **4** alternately so that the difference between the right and left margins should be 5mm or less.
 4. Adjust the vertical size and position of the picture area
 - Adjust **5** V.SIZE (vertical size) so that the screen end touches the border of green/white pattern at the center of the top/bottom of the screen.
 - Perform fine adjustment on **5** and **6** alternately so that the difference between the top and the bottom margins should be 5mm or less.

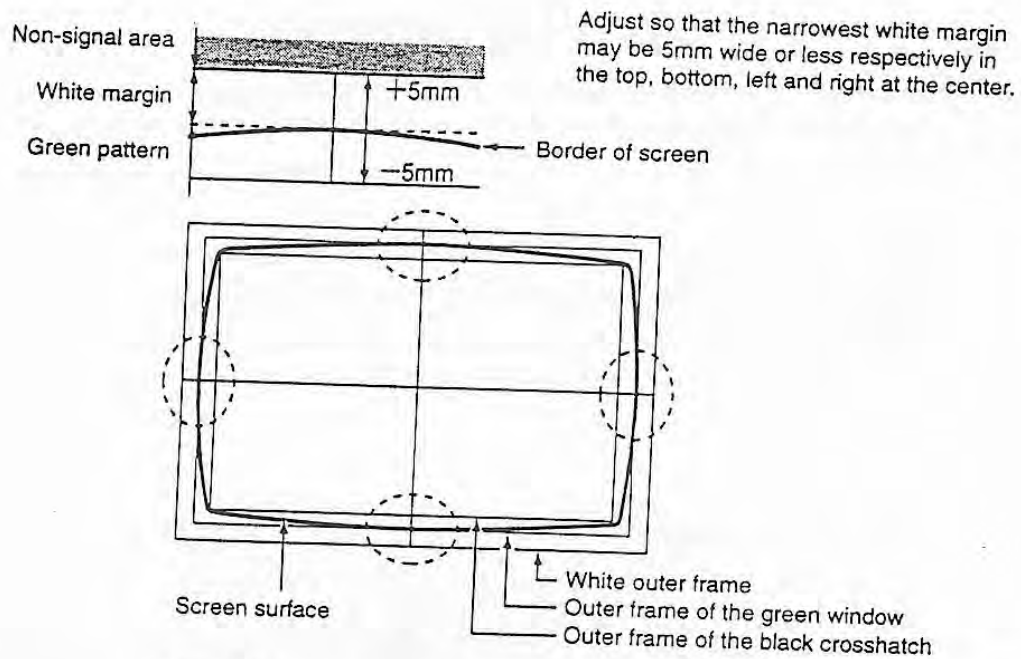

Fig. 3 Adjustment of screen size and position

<Contrast adjustment>

8 Contrast can be adjusted as follows:

1. While in the monitor test screen, display GRADATION PATTERN (Fig. 4 "16-Gradation Pattern").
2. Adjust ① CONTRAST (contrast) and ② BRIGHT (luminance) so that each color in the gradation pattern may have 16 clear tinted boxes (with the lower right box 100% black.)

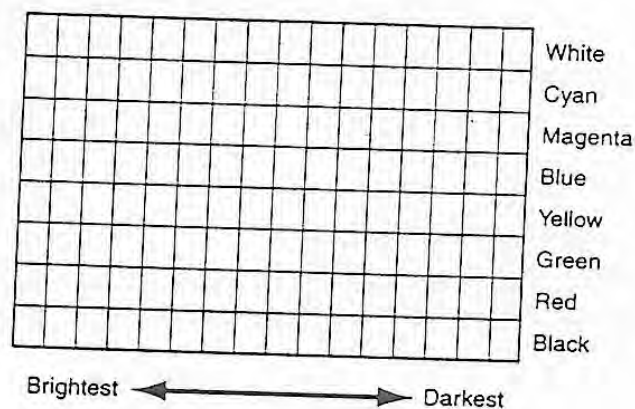

Fig. 4 16-gradation pattern

- 9** When adjustment is completed, install the maintenance panel in reverse order.
- 10** Turn off the test switch. The game screen returns.

(4) Detaching and reattaching the rack Assy



WARNING

- Before carrying out this task, always turn off the power switch to prevent workers and people around them from getting an electric shock, accident, or injury and to protect the electric circuit from damage.

- 1** Detach the rear cover. (See P-50, 8-3-1 (1) "Detaching and Reattaching the Rear Cover.")
- 2** Disconnect the five connectors at the locations illustrated below.
- 3** Loosen the two Phillips hexagon bolts (with flat and spring washers) (M6 × 16), pull the rack Assy a little towards yourself, then lift it up to detach.

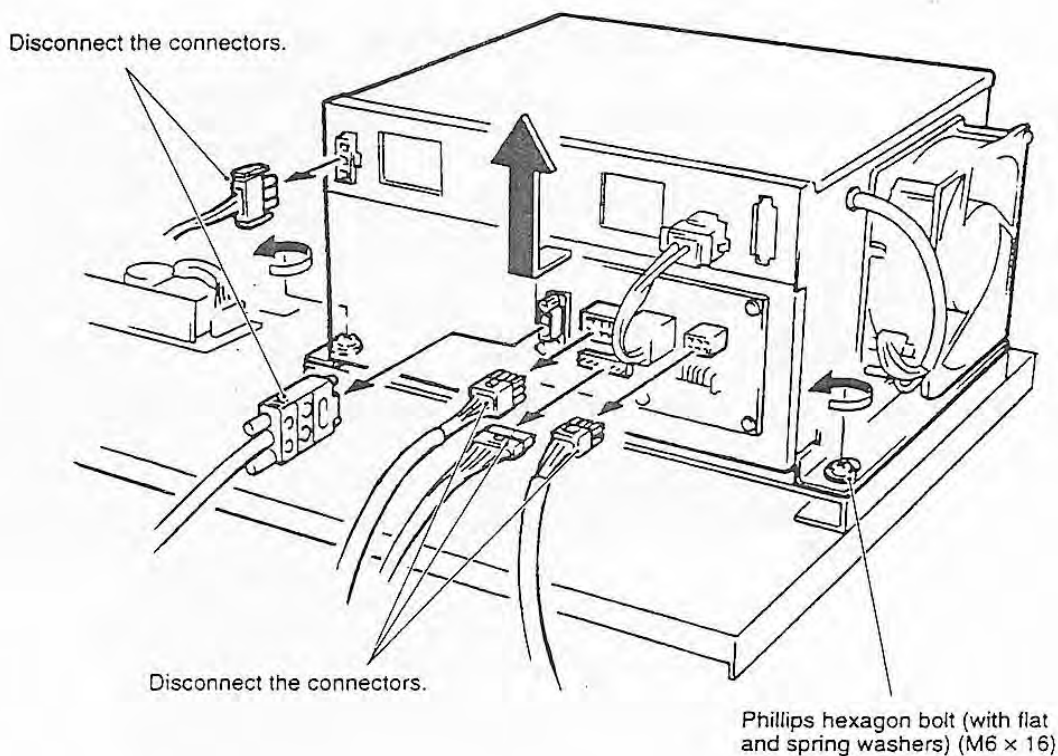

- 4** Reattach the rack Assy in reverse order.
- 5** After replacing, always check how this machine works and check the settings. (See P-31, 7-4 "Test Mode" and P-42, 7-5 "Setting the Gun aiming (GUN INITIALIZE).")

(5) Replacing the game PC board with a new one**WARNING**

- Before carrying out this task, always turn off the power switch to prevent workers and people around them from getting an electric shock, accident, or injury and to protect the electric circuit from damage.

- 1** Detach the rear cover. (See P-50, 8-3-1 (1) "Detaching and Reattaching the Rear Cover.")
- 2** Disconnect the six connectors.
- 3** Remove the four Phillips round head screws (with flat and spring washers) (M4 × 10) and detach the F panel (1).

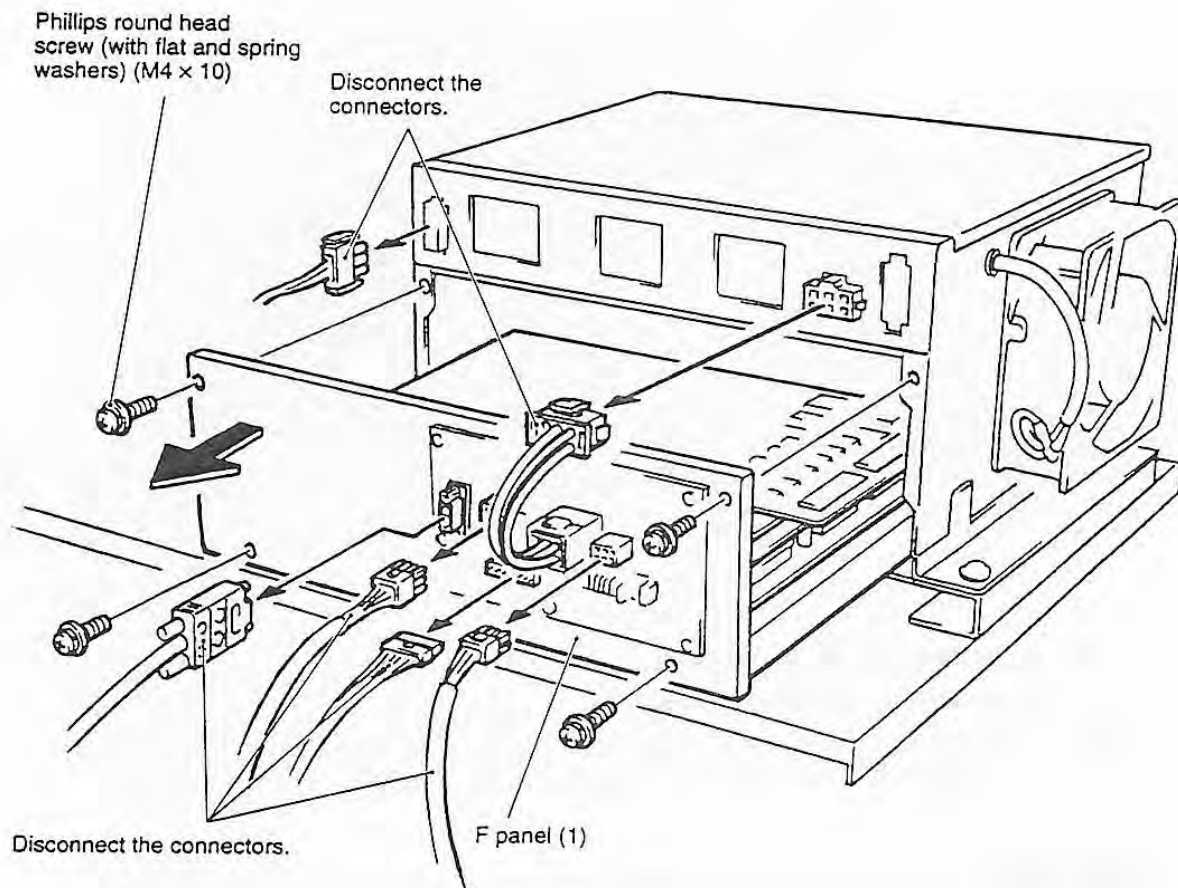

- 4 Remove the four Phillips round head screws (with flat and spring washers) (M3 × 6) from the top board and the four studs and the two Phillips round head screws (with flat and spring washers) (M3 × 6) from the bottom board. Then detach the two game PC boards.

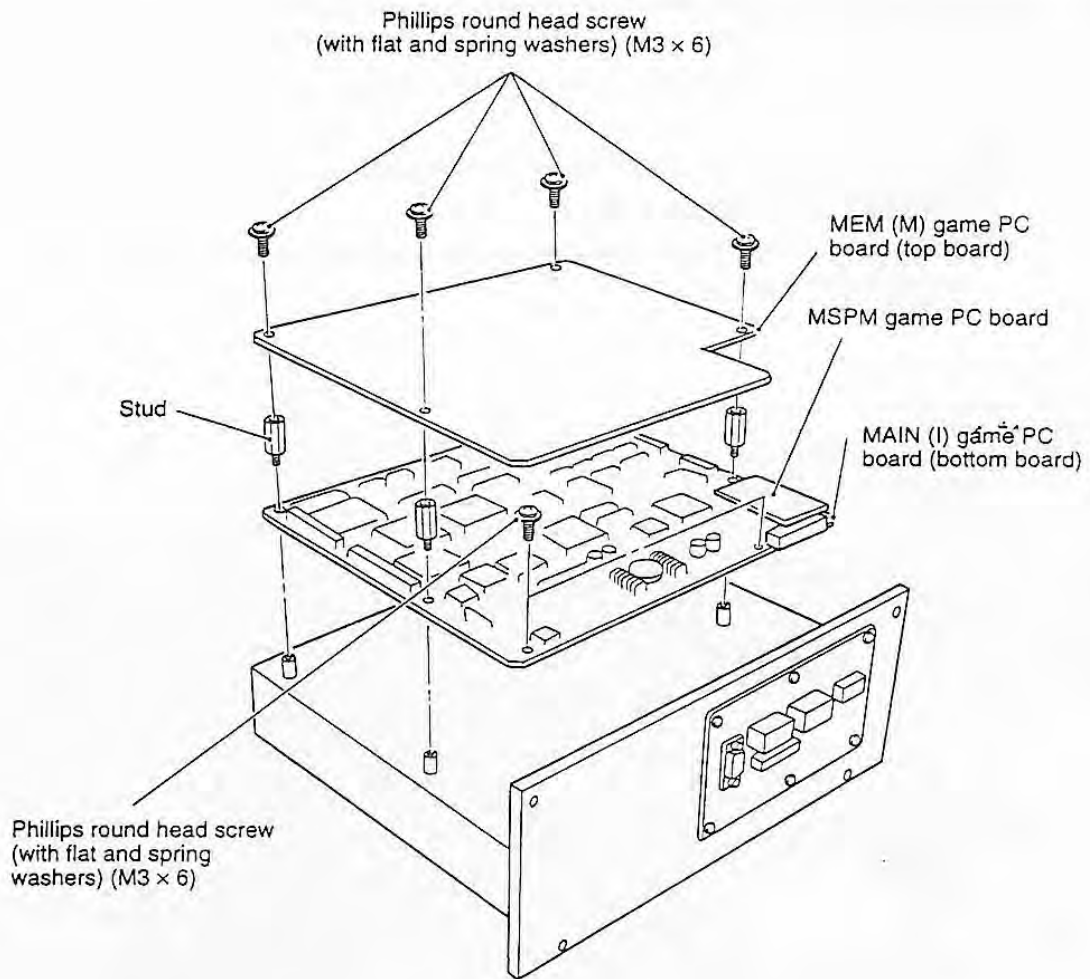

- 5 Attach new game PC boards in reverse order.
- 6 Reassemble them in reverse order.
- 7 After replacing, always check that this machine works and check the settings. (See P-31, 7-4 "Test Mode" and P-42, 7-5 "Setting the Gun Aiming (GUN INITIALIZE).")

NOTICE

- Before sending game PC boards, wrap them with a sponge, air cap, or something similar, and put them into a corrugated carton or something similar to avoid external forces.

8-3-2 Signboard Assy

– To be conducted by a technician only –

(1) Replacing the fluorescent lamp and glow lamp with new ones



WARNING

- Before carrying out this task, turn off the power switch to prevent workers and people around them from getting an electric shock, accident, or injury and to protect the electric circuit from damage.



CAUTION

- The fluorescent lamp can heat up to a high temperature. Take enough care when detaching it.
- Take enough care in replacing the fluorescent lamp and glow lamp, because such work is conducted at a high position.

- 1** Remove the four torque bolts (M5 × 12) and detach the stay while holding the signboard panel to detach.
- 2** Pull up the signboard panel.
- 3** Replace the fluorescent lamp (40W) or glow lamp.

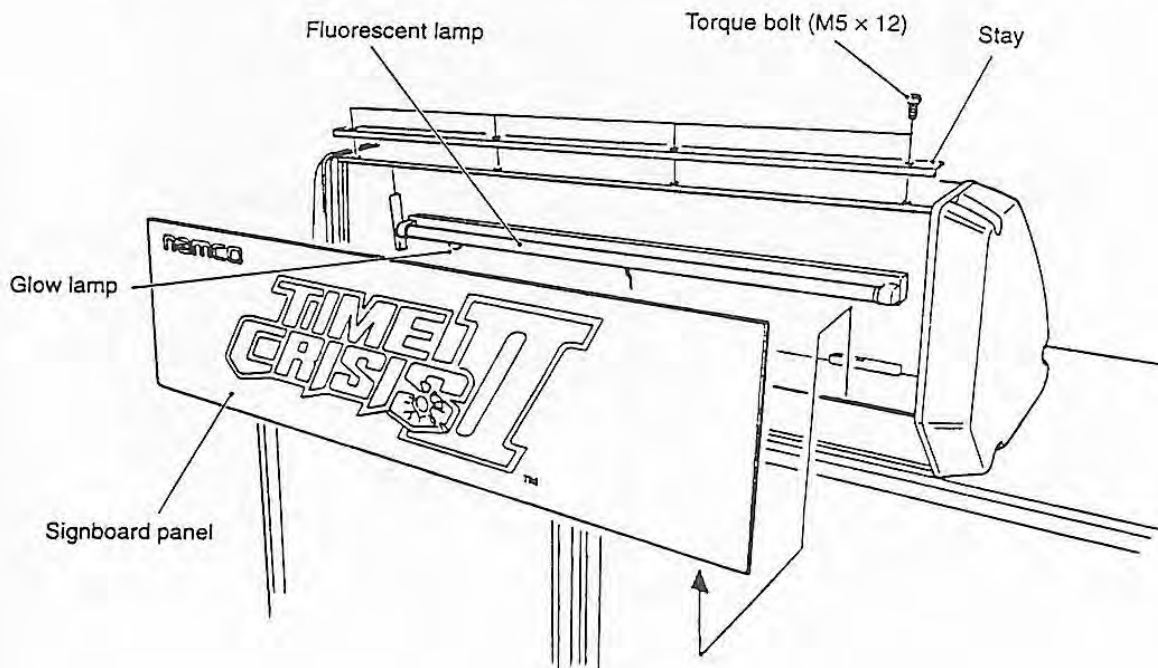

- 4** Reassemble in reverse order.

8-3-3 Tower Assy

– To be conducted by a technician only –

(1) Replacing the I/O PC board with a new one

NOTICE

- Before carrying out this task, always turn off the power switch to protect the electric circuit from damage.
- When disconnecting the connectors from the I/O PC board, always hold the I/O PC board.
- When connecting the connectors to the I/O PC board, insert the white connector to the top and the red one to the bottom I/O PC board.

- 1 Disassemble the pedal Assy, tower Assy from the cabinet Assy. (See P-21, 6-2-1 “Dividing” — To be conducted by a technician only).
- 2 Remove the six torque bolts (M5 × 12) and detach the back cover.

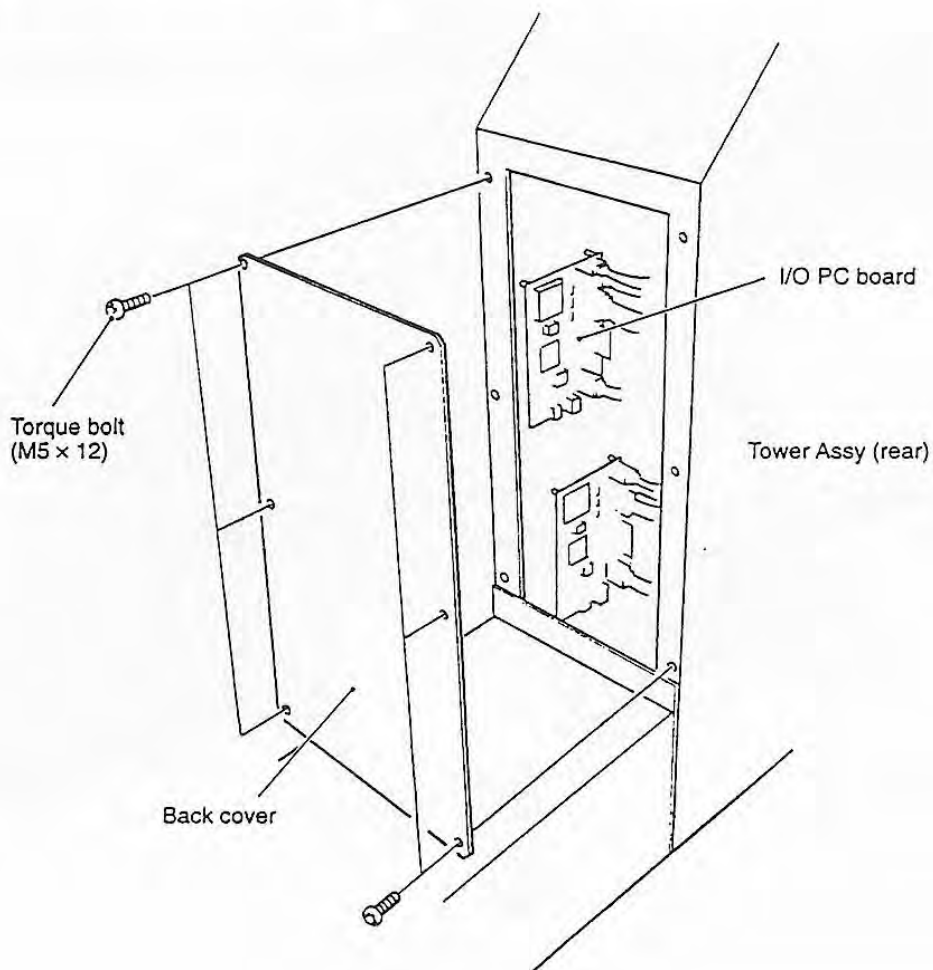

- 3 Disconnect the four connectors of the I/O PC board.
- 4 Remove the four cup screws (M) (M3 × 6), then detach the I/O PC board.

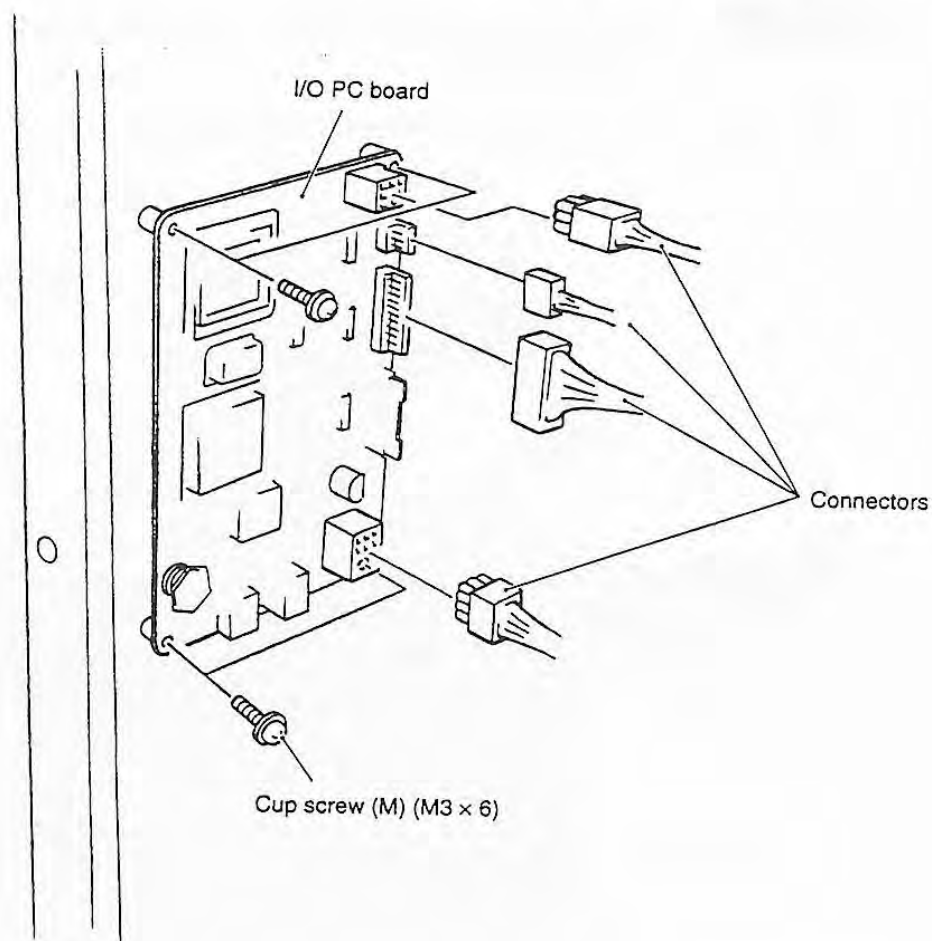

- 5 Attach a new board in reverse order.

8-3-4 Pedal Assy

- To be conducted by a technician only -

(1) Replacing the microswitch with a new one



- Before carrying out this task, always turn off the power switch to protect the electric circuit from damage.

- 1 Remove the four torque bolts (M5 × 12), then detach the cover.

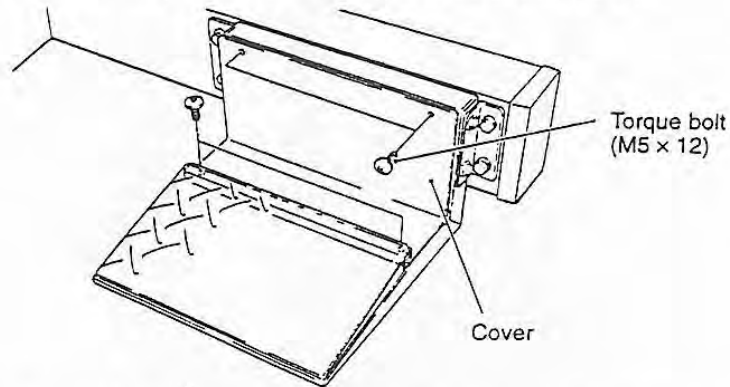

- 2 Remove the two Phillips round head screws (with flat and spring washers) (M3 × 16) and two fasten terminals, then detach the microswitch.

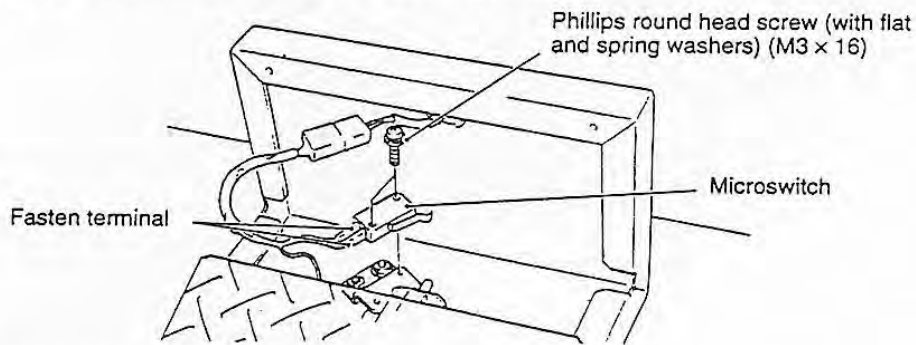

- 3 Replace the microswitch with a new one.
- 4 After replacing, press the pedal to check if the new microswitch works well.
- 5 If the microswitch does not work well, adjust it by loosening the two dished-head washer nuts (M4).

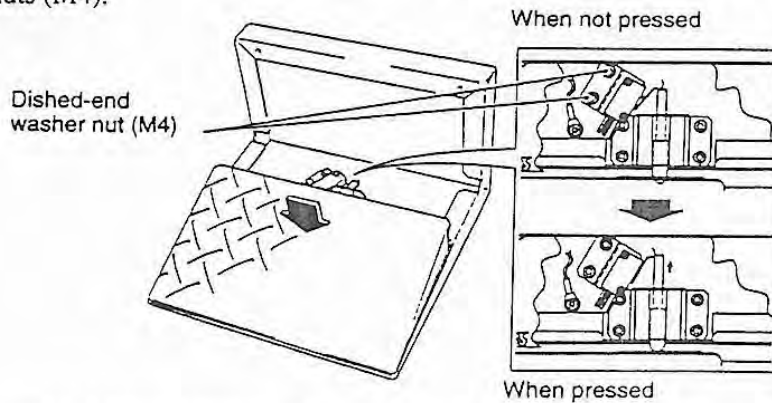

- 6 Attach the new microswitch in reverse order.

(2) Replacing the plunger with a new one



- Before carrying out this task, always turn off the power switch to protect the electric circuit from damage.

- 1 Detach the holder. (See P-45, 8-1-1 "Greasing the Plunger of the Pedal Assy.")
- 2 Pull the plunger out of the holder, then replace it with a new one. At that time, grease the new plunger all over.
 - Specified grease brand: Albania Grease No. 2 (Showa Shell)

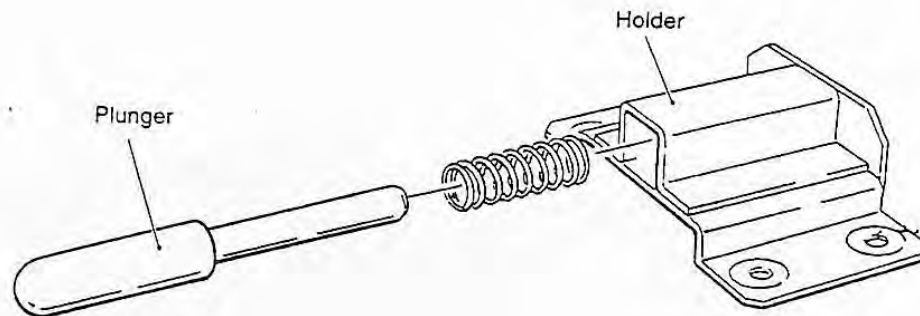

- 3 Wipe off the old grease from the plate of the pedal, then apply a new supply of grease to it.

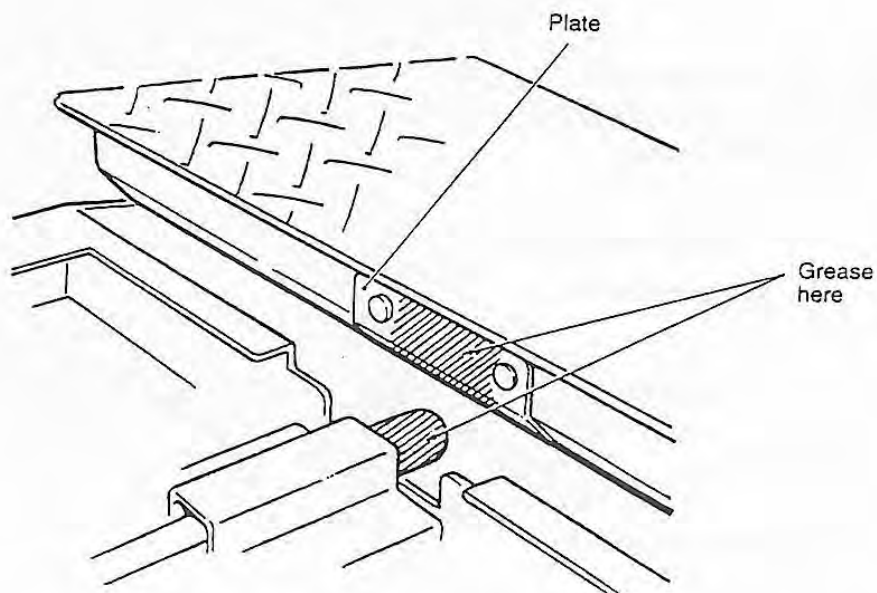

- 4 Reassemble in reverse order. (For adjusting the microswitch, see P-66, 8-3-4 (1) "Replacing the Microswitch with a New One.")

8-3-5 Gun Assy

– To be conducted by a technician only –

(1) Replacing the gun Assy with a new one



- Before carrying out this task, always turn off the power switch to protect the electric circuit from damage.

- 1 Remove the six torque bolts (M5 × 12) and detach the holder cover.

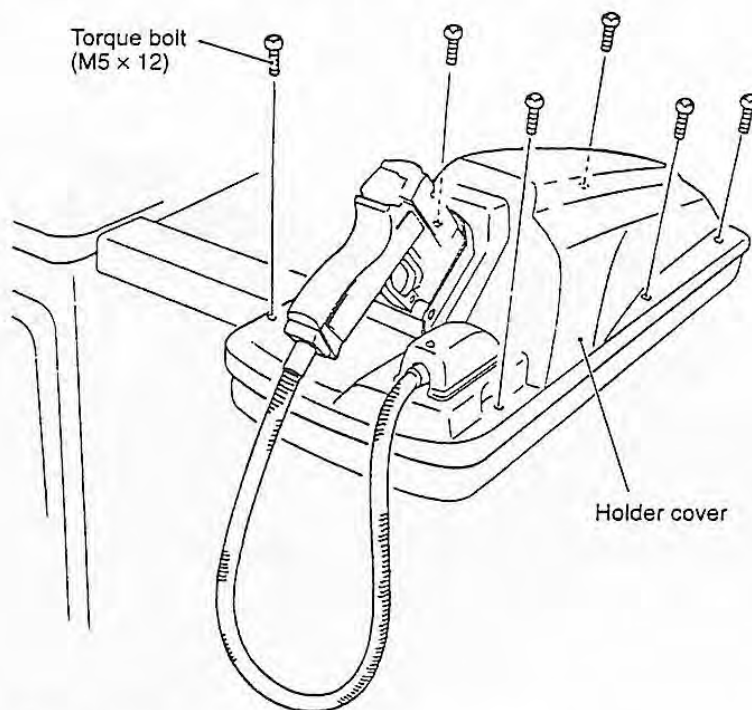

- 2 Disconnect the two connectors.
- 3 Remove the two dished-end washer nuts (M6) from the back of the holder cover and detach the gun Assy.

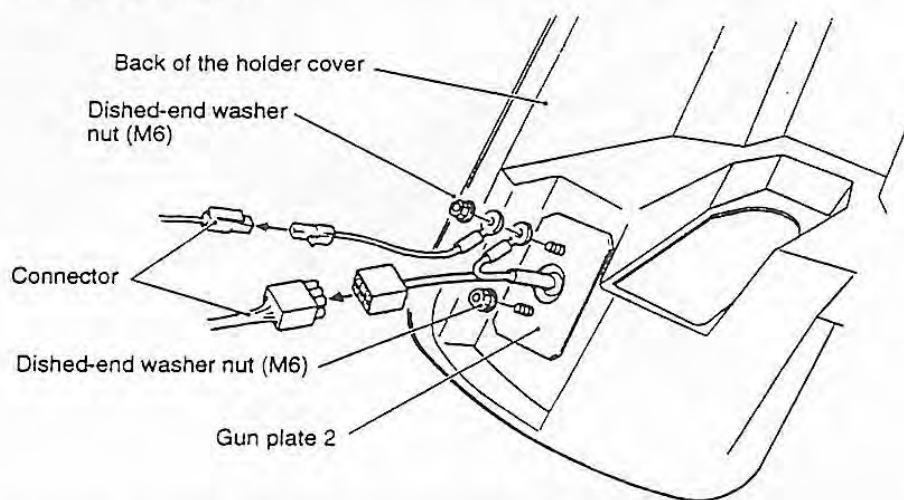

- 4 Attach the new gun Assy in reverse order.

(2) How to open the gun slide

NOTICE

- Before carrying out this task, always turn off the power switch to protect the electric circuit from damage.

- 1 Remove the four cap bolts (M3 × 10), one button bolt (M4 × 25), and one hexagon box nut (M4), then detach the gun slides (L) and (R).

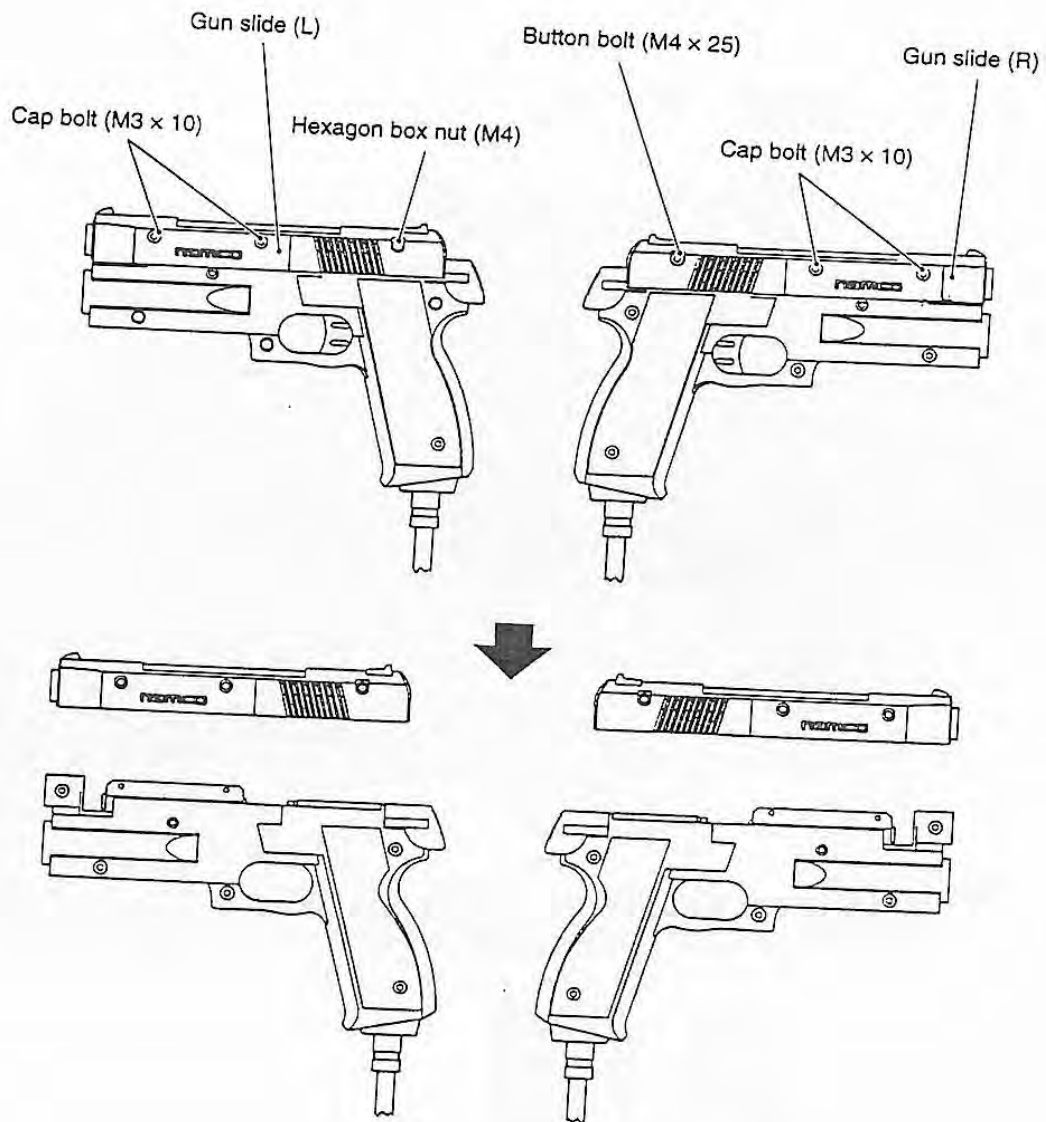

- 2 Attach the gun slide in reverse order.

(3) How to open the gun cover

NOTICE

- Before carrying out this task, always turn off the power switch to protect the electric circuit from damage.

- 1 Remove the gun slides (L) and (R). (See P-69, 8-3-5 (2) "How to Open the Gun Slide.")
- 2 Place the gun cover (L) face-down, and remove the four button bolts (M4 × 10), one button bolt (M4 × 25), four hexagon box nuts (M4), and one cap bolt (M3 × 10) fixing the gun cover (R). Then detach the gun cover (R). At that time, take care not to let the lens fall.

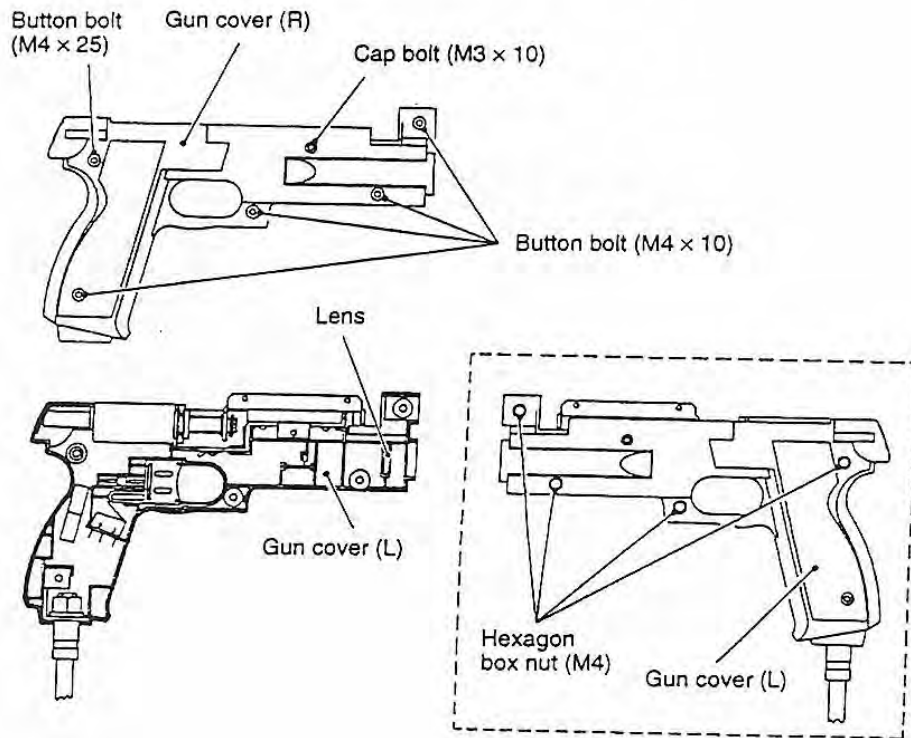

- 3 Reassemble in reverse order. At that time, pay attention to the direction of the lens. (Make the spherical face of the lens face toward the muzzle.)

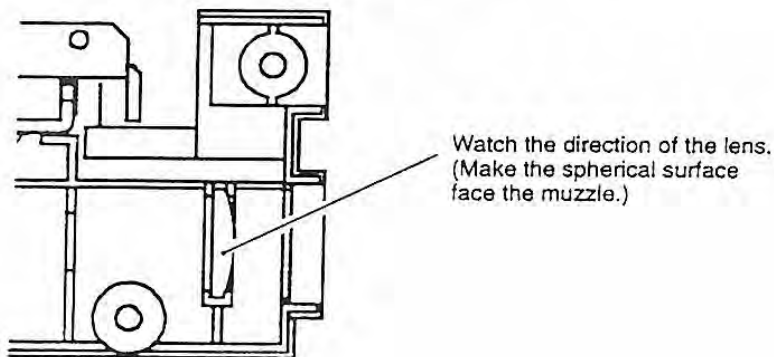

(4) Replacing the solenoid with a new one



- Before carrying out this task, always turn off the power switch to protect the electric circuit from damage.

- 1 Detach the gun cover and gun slide.
(See P-69, 8-3-5 (2) "How to Open the Gun Slide" and P-70, 8-3-5 (3) "How to Open the Gun Cover.")
- 2 Disconnect the connectors of the solenoid.
- 3 Remove the cap bolt (M3 × 10) on the gun cover (L) and detach the solenoid bracket.
- 4 Remove the cup screw (M) (M3 × 8) and detach the ground wire.
- 5 Loosen the nuts (16mm in nominal diameter) fixing the solenoid.
- 6 Pull out the solenoid.
- 7 Remove the two cup screws (M) (M4 × 6) and detach the slide guide.
- 8 Pull out the solenoid plunger. At that time, take care not to lose the spring.

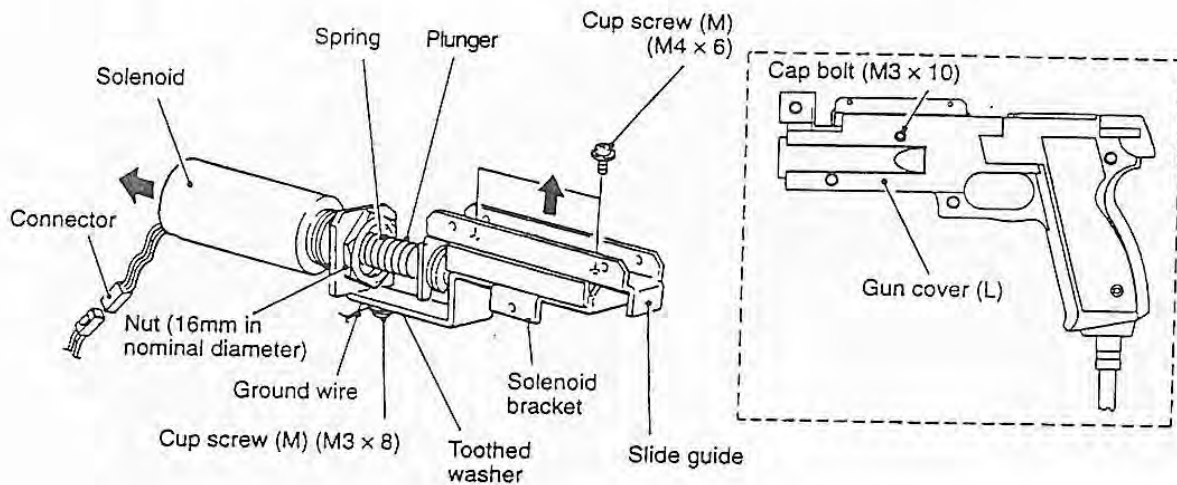

- 9 Attach the components in reverse order. At that time, match the D-type hole of the solenoid bracket to the D shape of the solenoid. Also pay attention to the order to attach the E-type snap rings and spacers.

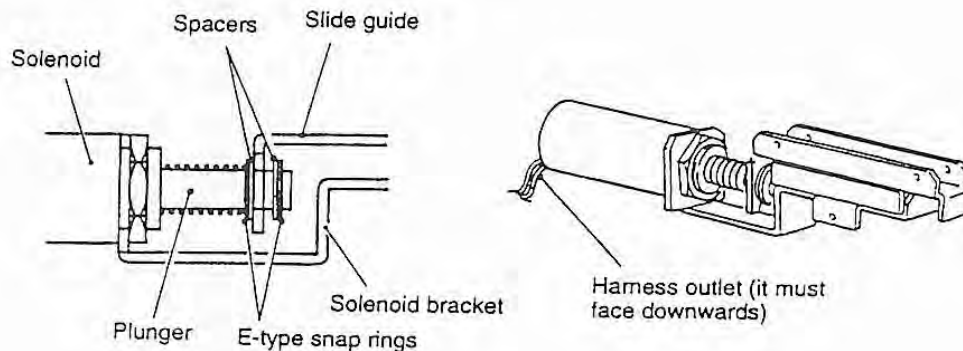

(5) Replacing the microswitch with a new one

NOTICE

- Before carrying out this task, always turn off the power switch to protect the electric circuit from damage.

- 1 Detach the gun cover (R) and gun slide (R). (See P-69, 8-3-5 (2) "How to Open the Gun Slide" and P-70, 8-3-5 (3) "How to Open the Gun Cover.")
- 2 Replace the microswitch with a new one.
- 3 Attach the new microswitch in reverse order.

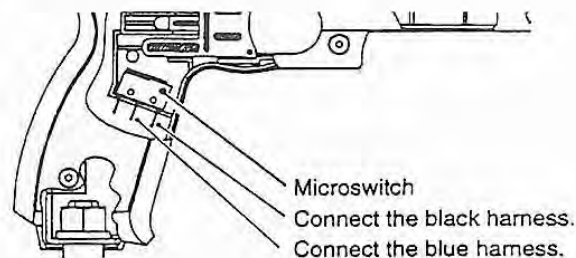

(6) Replacing the tube with a new one

NOTICE

- Before carrying out this task, always turn off the power switch to protect the electric circuit from damage.

- 1 Remove the gun Assy. (See P-68, 8-3-5 (1) "Replacing the Gun Assy.")
- 2 Remove the two button bolts (M4 × 10), then detach the connector cover.
- 3 Remove the gun slides (L) and (R) and gun cover (R). (See P-70, 8-3-5 (3) "How to Open the Gun Cover.")
- 4 Detach the solenoid bracket and detach the solenoid connectors and ground wire. (See P-71, 8-3-5 (4) "How to Replace the Solenoid with a New One.")
- 5 Disconnect the connectors of the sensor and the fasten terminals of the microswitch.
- 6 Remove the button bolt (M4 × 10) fixing the tube to the gun cover (L) to detach the tube.
- 7 Attach the new tube in reverse order.

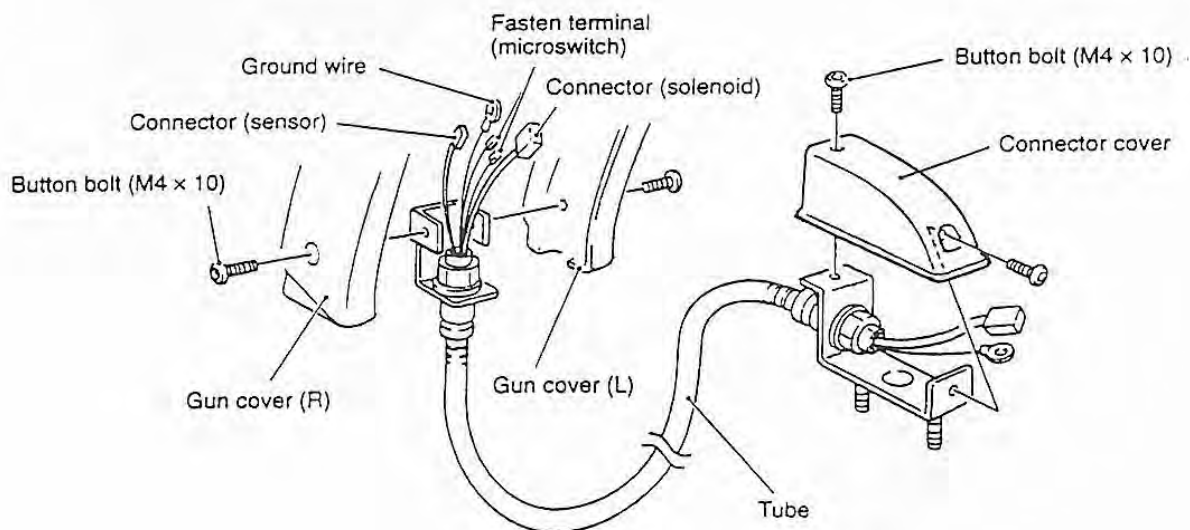

9. DISCARD



WARNING

- Before discarding this machine, collect, transport, and dispose of its components according to relevant laws.
- If you wish to entrust a third party to collect, transport, and dispose of this machine to discard, employ agents specializing in the respective works.

10. PARTS LIST

10-1 Cabinet Assy

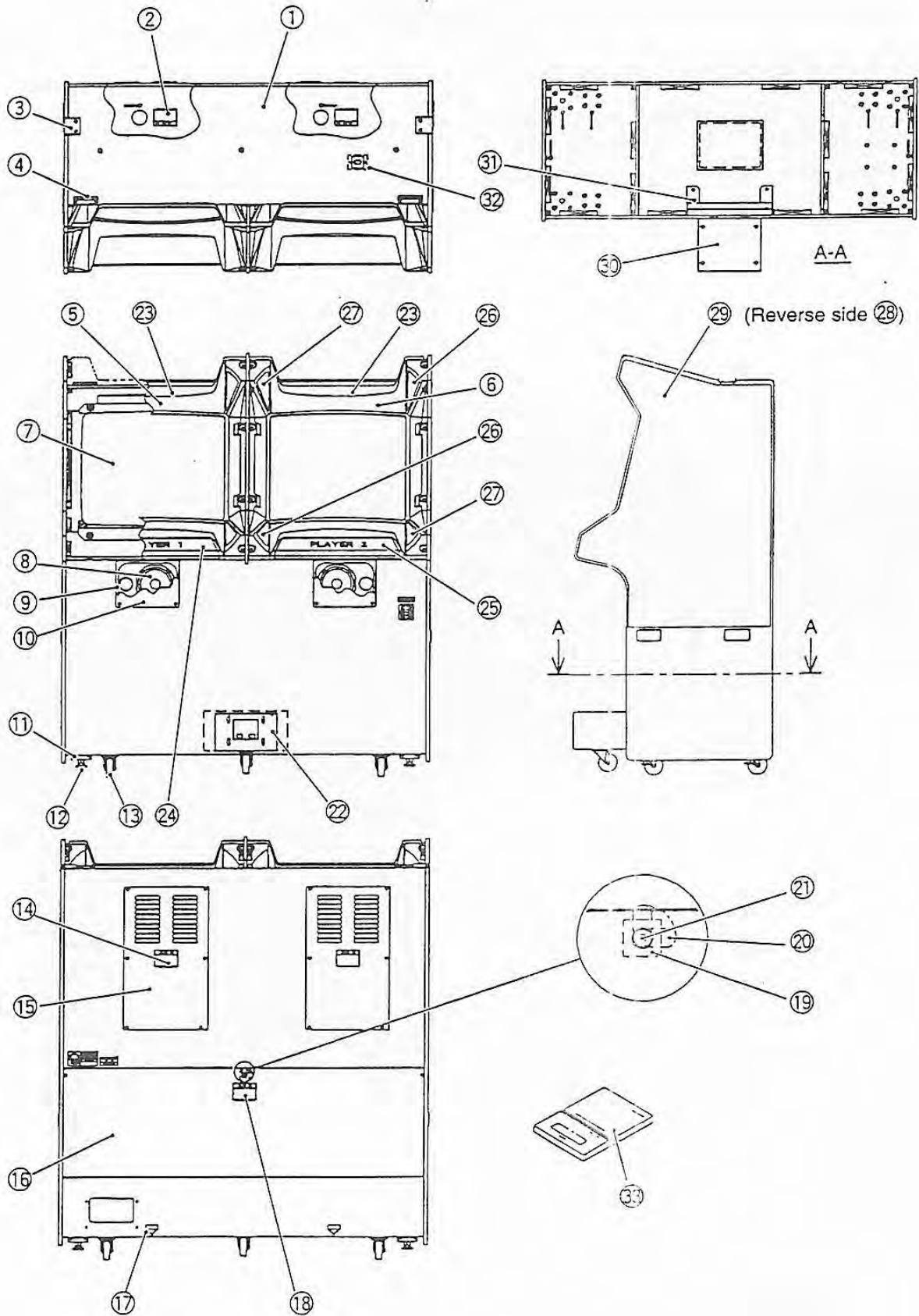

10. PARTS LIST

No.	Part	Q'ty	Model and rating	Part #
1	Cabinet	1		
2	Warning sticker (inside)	2		671-113
3	Rope hook	2		461-376
4	Signboard hook	2		671-120
5	Monitor mask (L)	1		671-126
6	Monitor mask (R)	1		671-125
7	Monitor	2		671-175
8	Woofers speaker	2	MS9-29NDR23 (Nanao) or TC-L292NJM2 (Toei)	—
9	Pipe duct	2	SWM1034 A/E	006-115
10	Woofers cover	2	LQ242 (L 150mm)	006-116
11	Adjustor bracket	4		671-115
12	Adjustment bolt	4	M16 × 75	450-120
13	Caster	5	420S-N 75m/m	102-166
14	Warning sticker (high voltage)	2		102-013
15	Maintenance panel	2		461-371
16	Rear cover	1		671-121
17	Fork sticker	2		671-123
18	Caution sticker (maintenance)	1		229-441
19	Key washer	1		461-359
20	Buckle (thin)	1	Double duty type 2.3mm thick	450-124
21	Coin lock	2	C-88-1 (random numbers)	101-011
22	Joint	1		
23	Blackout sticker (T)	2		671-116
24	Blackout sticker (UL)	1		
25	Blackout sticker (UR)	1	Set of blackout stickers (L, R, and T)	671-118
26	Aim sticker (A)	4		
27	Aim sticker (B)	4	Set of aim stickers (A and B)	671-162
28	Side panel sticker (A)	1		
29	Side panel sticker (B)	1		671-111
30	Joint cover	1		671-161
31	Joint stay	1		671-124
32	Connector plate	1		671-117
33	Operation Manual (this manual)	1		671-122
				671-005

*1: To order a part No. 21 with a specified number (the same number), contact your dealer.

10-2 Signboard Assy

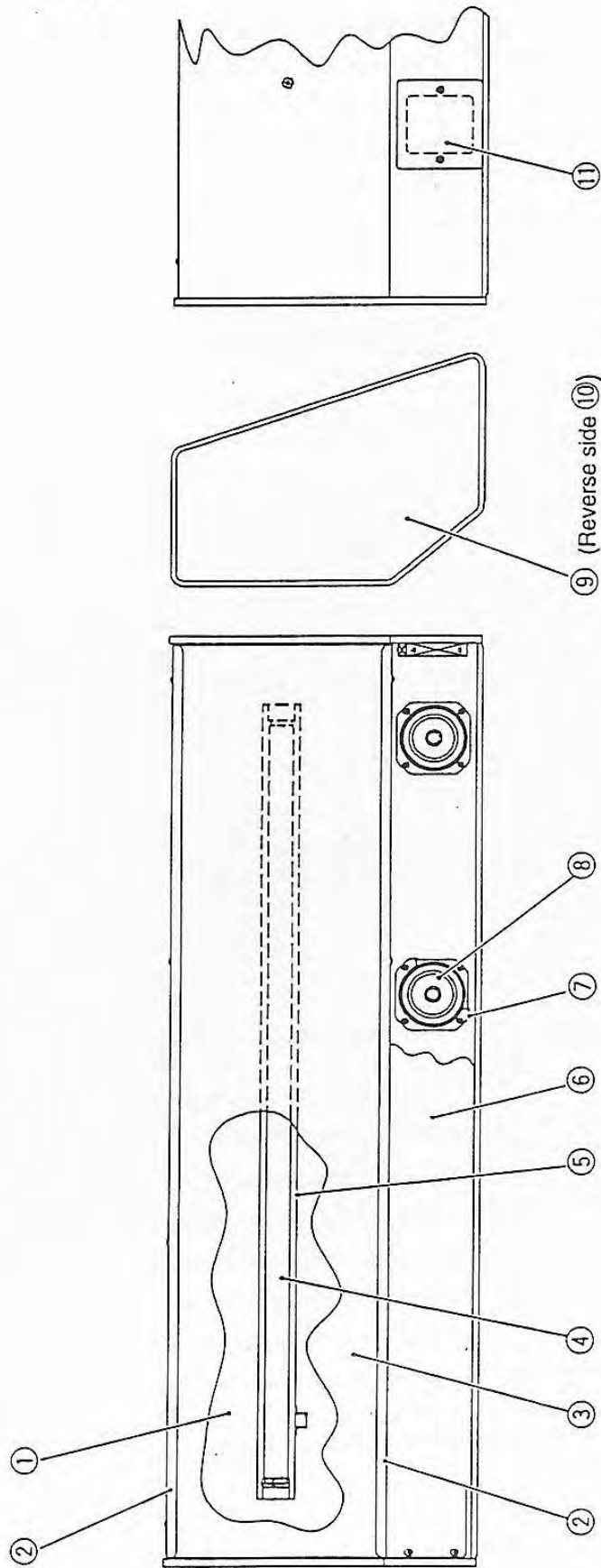

No.	Part	Q'ty	Model and rating	Part #
1	Box	1		671-211
2	Stay	2		671-214
3	Signboard panel	1		671-212
4	Fluorescent lamp	1	FL-40W	—
5	Fluorescent lamp fixture	1	M4111A	—
6	Speaker cover	1		671-215
7	Speaker mask	4		671-217
8	Speaker	4	EAS10P542A	006-108
9	Signboard side sticker (R)	1		671-263
10	Signboard side sticker (L)	1		671-213
11	Connector cover	1		671-216

10-3 Control base Assy

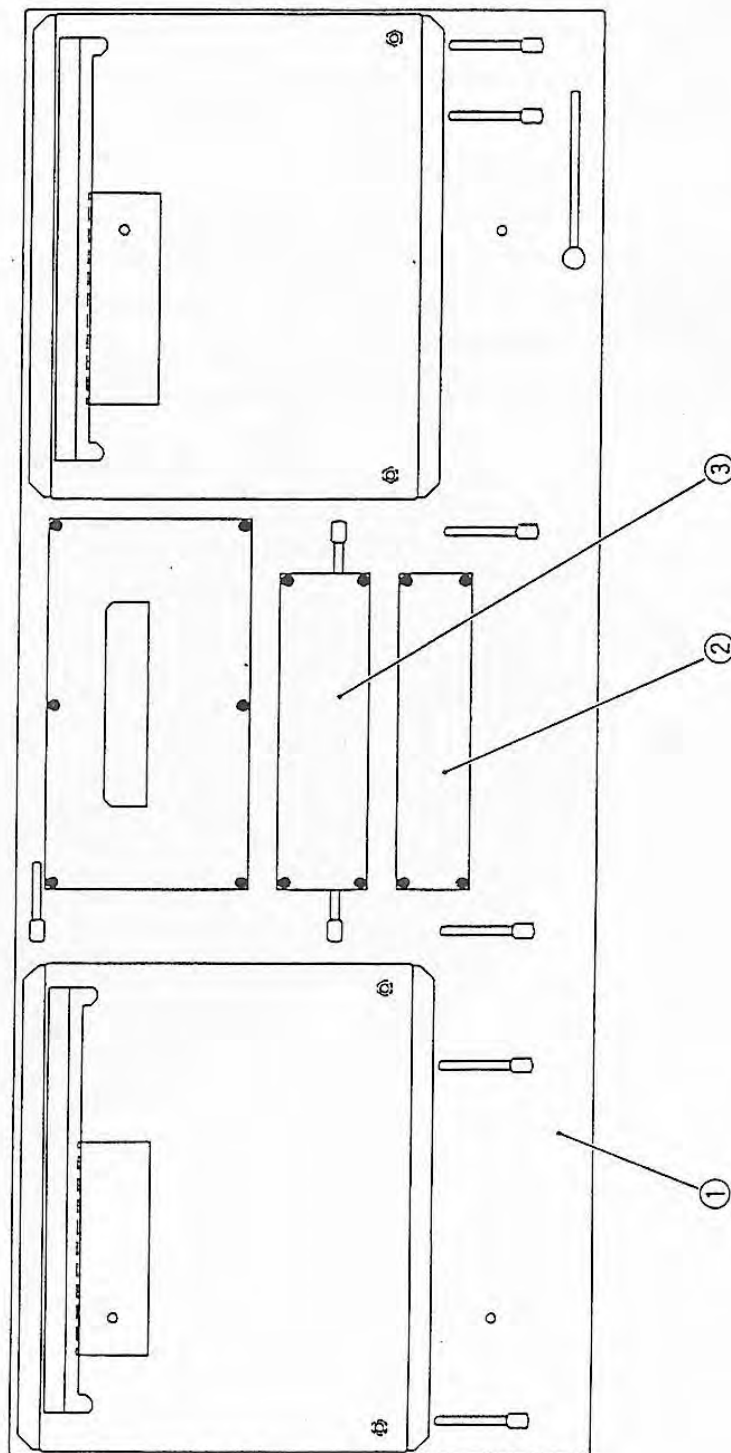

10. PARTS LIST

No.	Part	Q'ty	Model and rating	Part #
1	Control base	1		671-311
2	Switching regulator	1	VS75B-24 (24V 75W)	009-117
3	Switching regulator	1	VS100B-12 (12V 100W)	009-116

10-4 Rack Assy

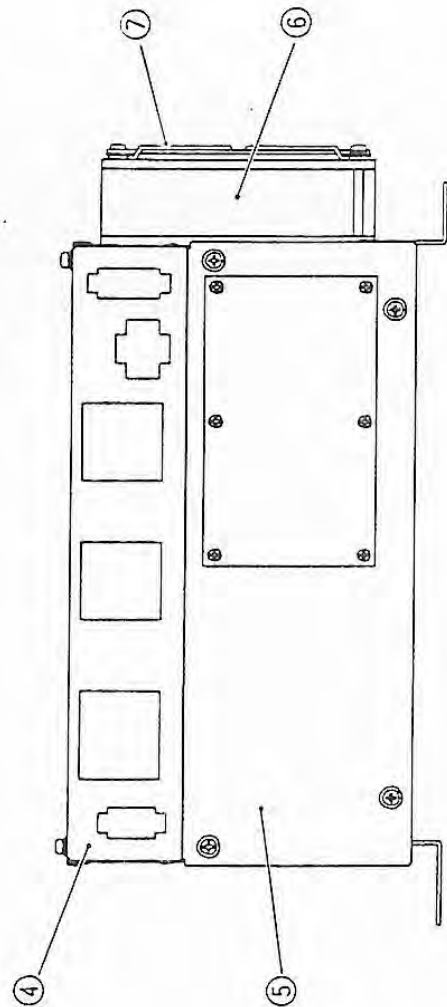
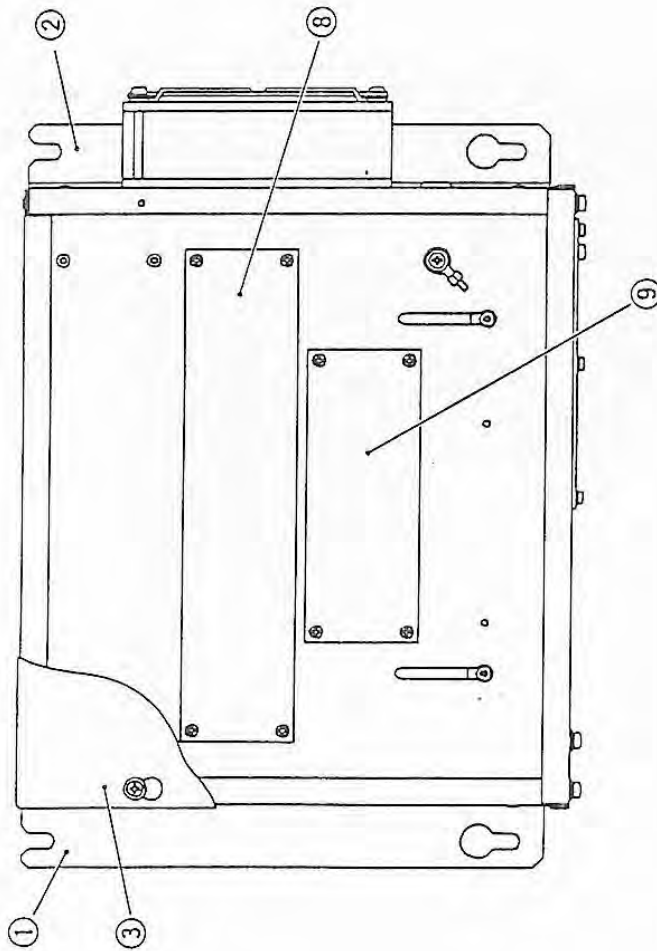
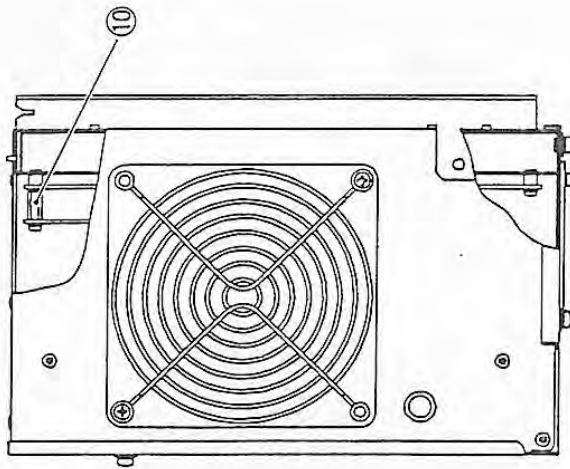

10. PARTS LIST

No.	Part	Q'ty	Model and rating	Part #
1	Bracket (L)	1		461-050
2	Bracket (R)	1		461-051
3	Cover	1		461-716
4	Case	1		461-718
5	F panel (1)	1		461-719
6	Fan motor	1	4715MS-10T-B50-B00	005-209
7	Finger guard	1	B-5	—
8	Switching regulator	1	VS75B-5 (5V 75W)	009-111
9	Switching regulator	1	VS30B-3 (3V 30W)	009-100
10	Stud	4		461-717

10-5 Cord box Assy

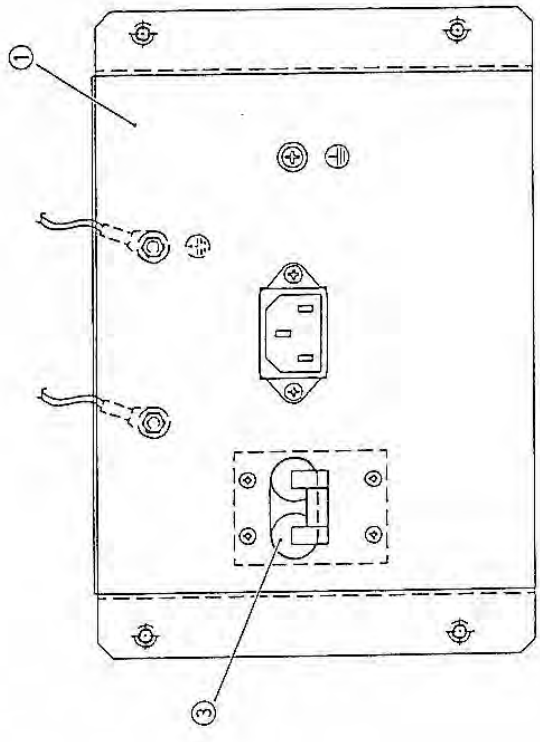
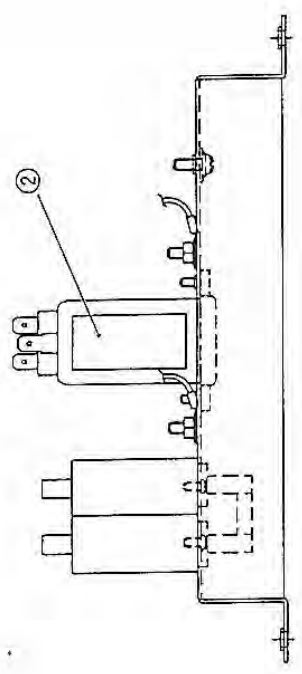
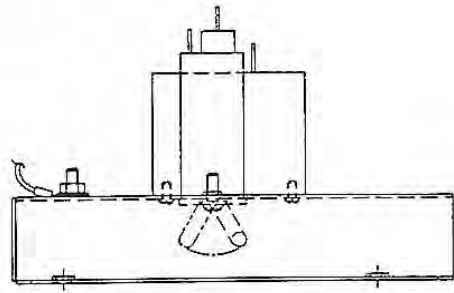

No.	Part	Q'ty	Model and rating	Part #
1	Cord box	1		671-411
2	Noise filter	1	SUP-C4210-F	—
3	Power switch	1	CP-S2PA1-M7.5A or CP32EM7.5	—

10-6 Tower Assy

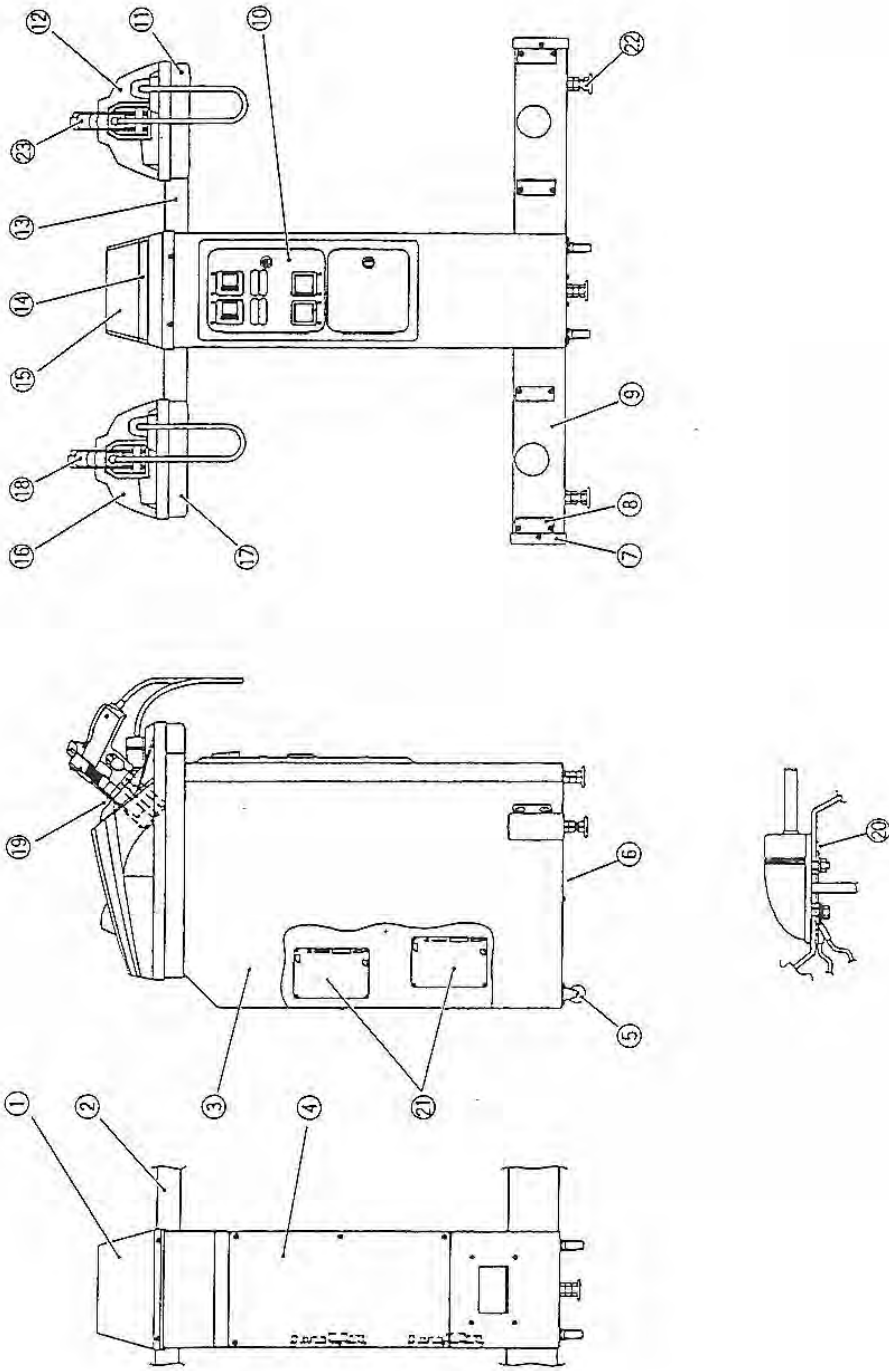



No.	Part	Q'ty	Material	Part #
1	Coin cover	1		671-622
2	Beam (B)	1		671-615
3	Main tower	1		671-611
4	Back cover	1		671-616
5	Caster	2	420R-N 3	102-054
6	Bottom cover	1		671-617
7	Pipe cover	2		671-619
8	Pedal bracket	4		631-115
9	Underpipe	1		671-613
10	Coin Assy	1		— ¹⁾
11	Gun base (R)	1		671-662
12	Holder cover (R)	1		671-673
13	Beam (A)	1		671-614
14	Pop sticker	1	Set of p.p.	671-660
15	Description sticker	1		
16	Holder cover (L)	1		671-623
17	Gun base (L)	1		671-612
18	Gun Assy (R)	1		295-902 ²⁾
19	Gun holder	2		671-618
20	Gun plate 2	2		671-511
21	V185 I/O PC board	2		
22	Adjustor bolt	3	M. 5 x 7	102-166
23	Gun Assy (B)	1		295-903

¹⁾ For No. 10, see P-90 10-9 "Coin Assy."

²⁾ For Nos. 18 and 23, see P-88, 10-8 "Gun Assy."

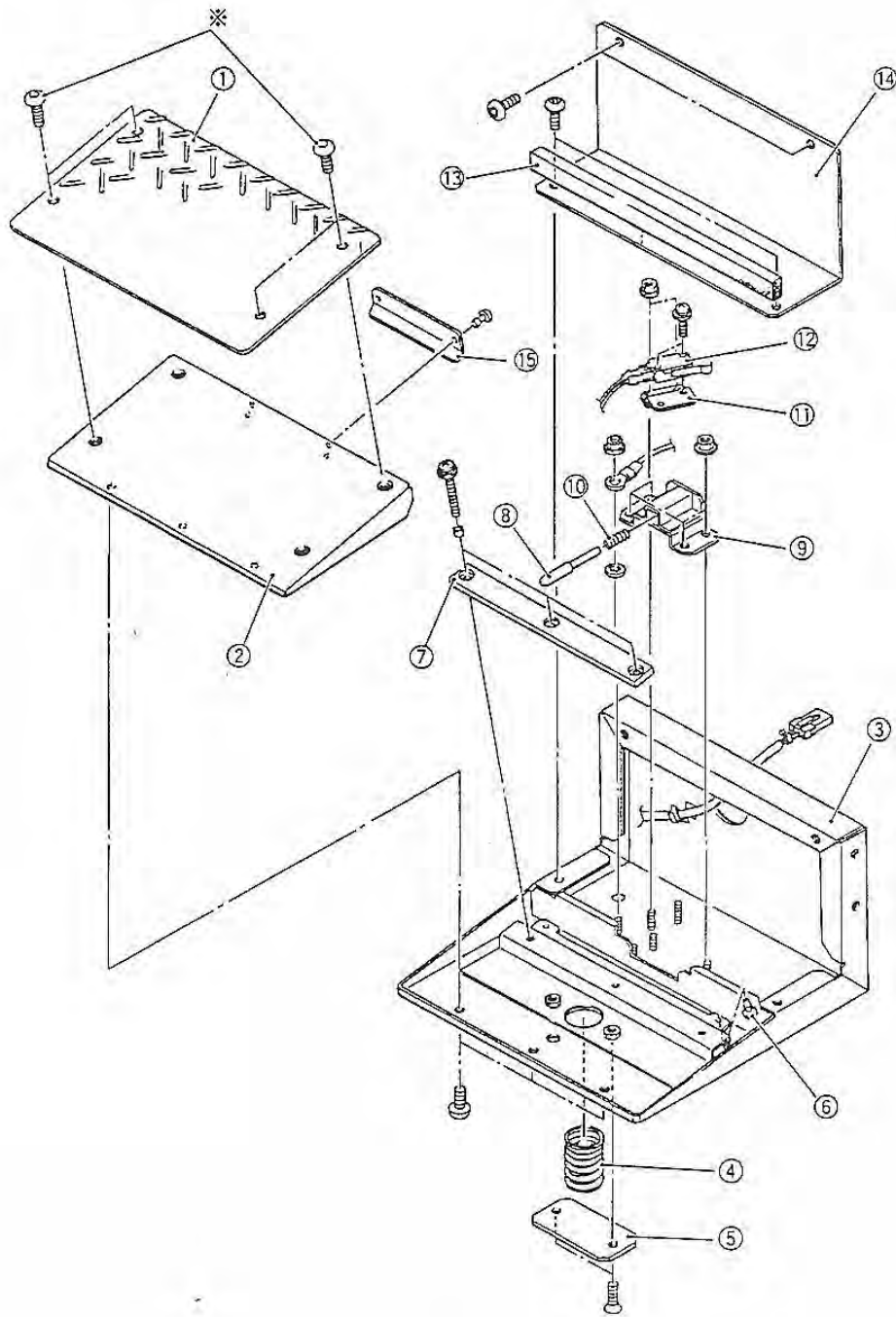
10-7 Pedal Assy



When ※ is of the hexagon socket head button bolt type. [Hexagon socket head button bolt: ]

No.	Part	Q'ty	Model and rating	Part #
1	Pedal plate	1		631-215
2	Pedal	1		631-212
3	Pedal base	1		631-211
4	Spring (A)	1		631-221
5	Spring cover	1		631-218
6	Rubber plug cushion	2	TM-96, article # 3	106-017
7	Rubber stopper	1		631-217
8	Plunger	1		631-219
9	Holder	1		631-213
10	Spring (B)	1		631-222
11	Switch stay	1		631-220
12	Microswitch	1	K3L 13	000-027
13	Epto sealer	1	Sealant EE-910 W10 × t15 × L248	106-041
14	Cover	1		631-214
15	Plate	1		631-216

When ※ is of the flush screw type.

No.	Part	Q'ty	Model and rating	Part #
1	Floor plate	1		631-255
2	Pivot	1		631-252
3	Main body	1		631-251
4	Spring (A)	1		631-221
5	Spring cover	1		631-218
6	Rubber plug cushion	2	TM-96, article # 3	106-017
7	Rubber stopper	1		631-217
8	Plunger	1		631-219
9	Holder	1		631-213
10	Spring (B)	1		631-222
11	Switch stay	1		631-220
12	Microswitch	1	K3L 13	000-027
13	Epto sealer	1	Sealant EE-910 W10 × t15 × L248	106-041
14	Front cover	1		631-254
15	Plate	1		631-216

10-8 Gun Assy

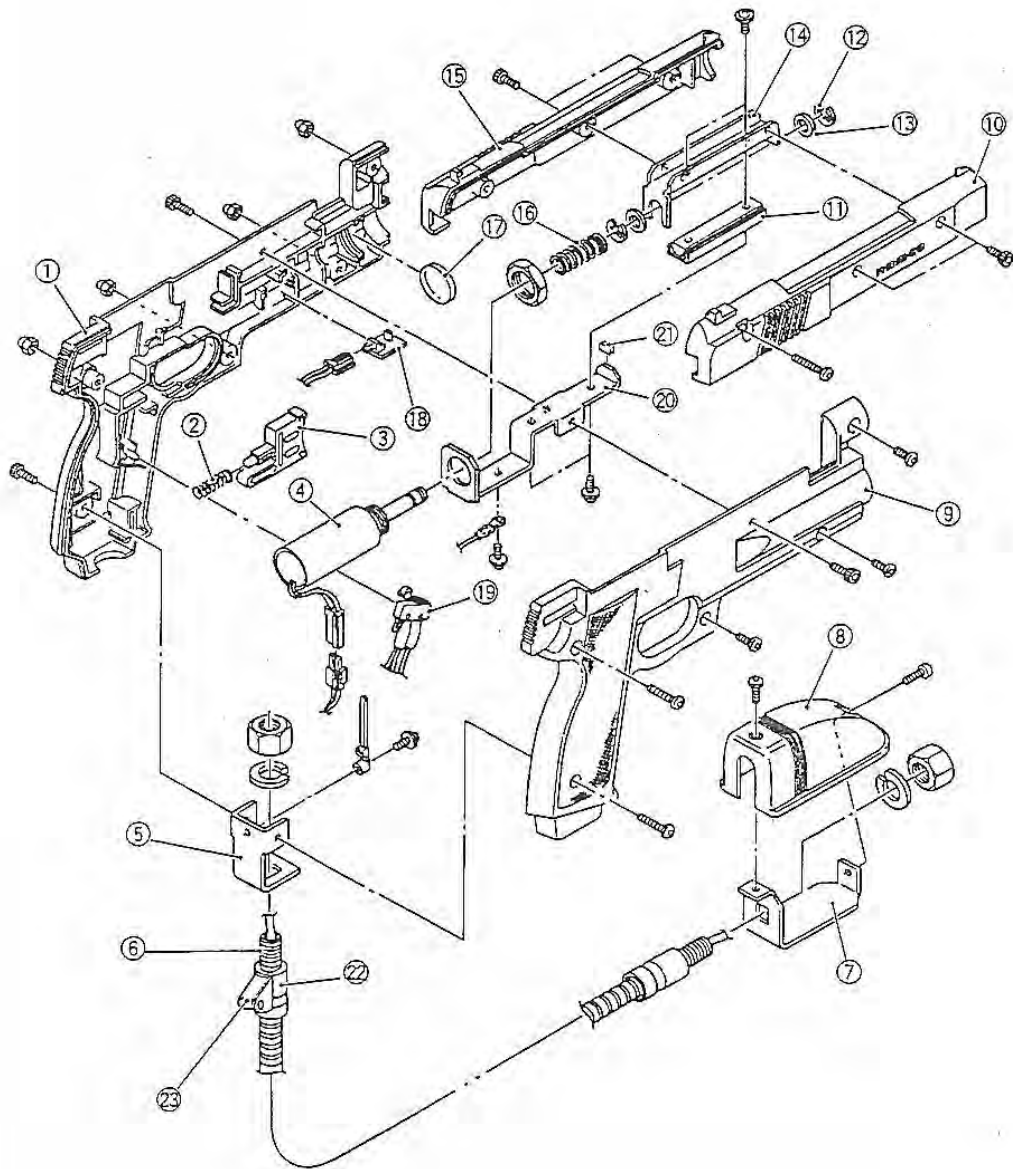

Gun Assy (R) (red)

No.	Part	Q'ty	Model and rating	Part #
1	Gun cover (L-R)	1		296-481
2	Trigger spring	1		296-421
3	Trigger (R)	1		296-485
4	Solenoid	1	ST-0860A2	004-056
5	Tube bracket (A)	1		296-418
6	Gun cord harness Assy (EXP)	1		296-402
7	Tube bracket (B)	1		296-423
8	Connector cover	1		296-424
9	Gun cover (R-R)	1		296-482
10	Gun slide (R-R)	1		296-484
11	Slide rail	1	E20+F15R2/60L	296-425
12	E-type snap ring	2	7CR-3 (10 dia)	110-002
13	Spacer	2		296-422
14	Slide guide	1		296-417
15	Gun slide (L-R)	1		296-483
16	Back spring	1		296-420
17	Lens	1	NA-V1472050	296-466
18	Sensor PCB	1		296-467
19	Microswitch	1	SS-01GL2T	000-228
20	Solenoid bracket	1		296-416
21	Rubber sound absorber	1		296-428
22	Chain bracket	1		296-468
23	Chain spacer	1		296-469
	Gun Assy (R)	1		296-902

Gun Assy (B) (blue)

No.	Part	Q'ty	Model and rating	Part #
1	Gun cover (L-B)	1		296-491
3	Trigger (B)	1		296-495
9	Gun cover (R-B)	1		296-492
10	Gun slide (R-B)	1		296-494
15	Gun slide (L-B)	1		296-493
	Gun Assy (B)	1		296-903

10-9 Coin Assy

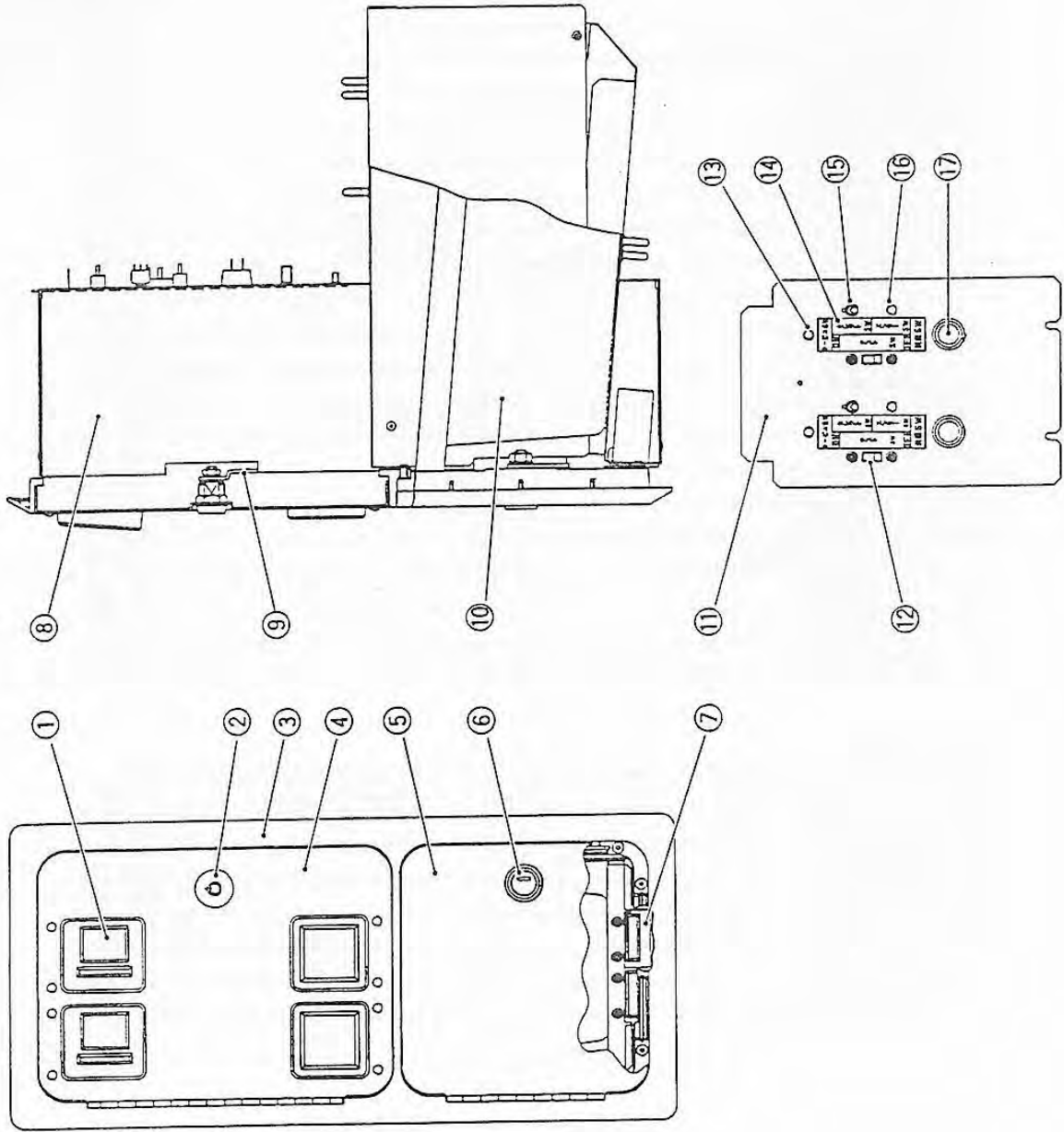

11. Wiring Diagram

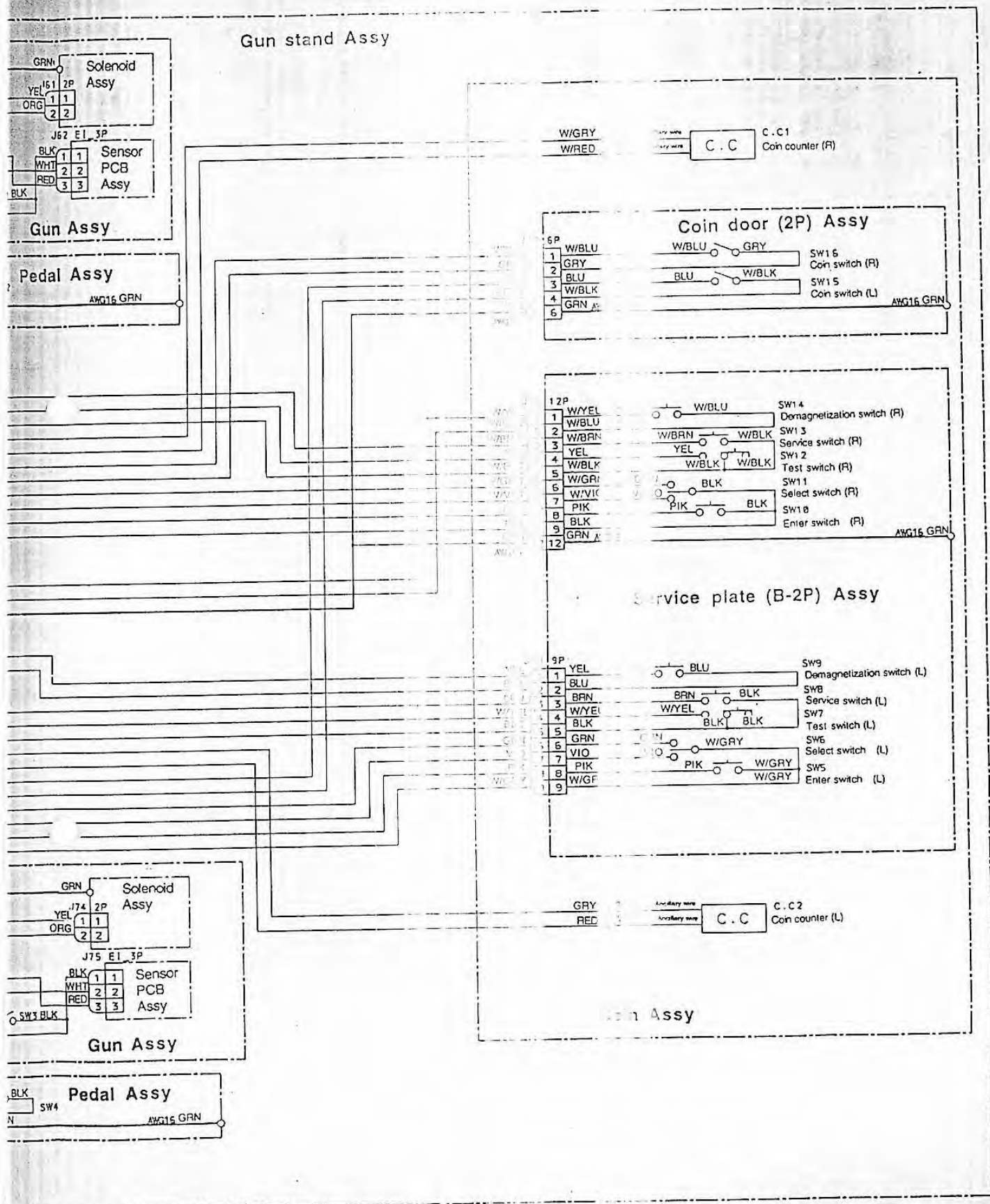

Tower Assy

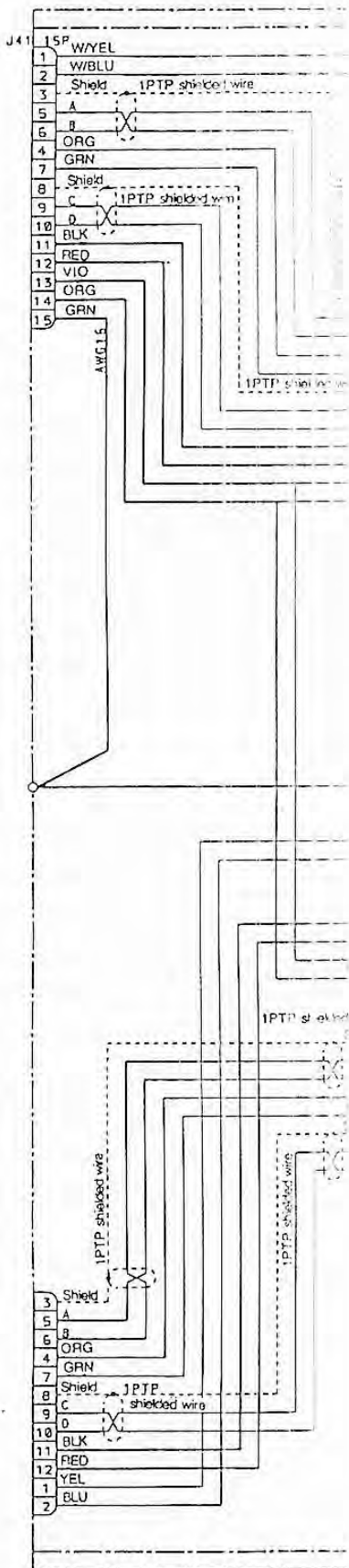

185
/0

- QND
- D+
- D-
- SENSE
- QND
- QND
- YQND
- SYNC
- QND
- +5V
- QND
- +24V

EL
U
AWG16

- E1
- 1
- 2
- 3
- 4
- 5
- 6
- 7
- 8
- 9
- 10
- 11
- 12

1/0

- E
- S

Tower

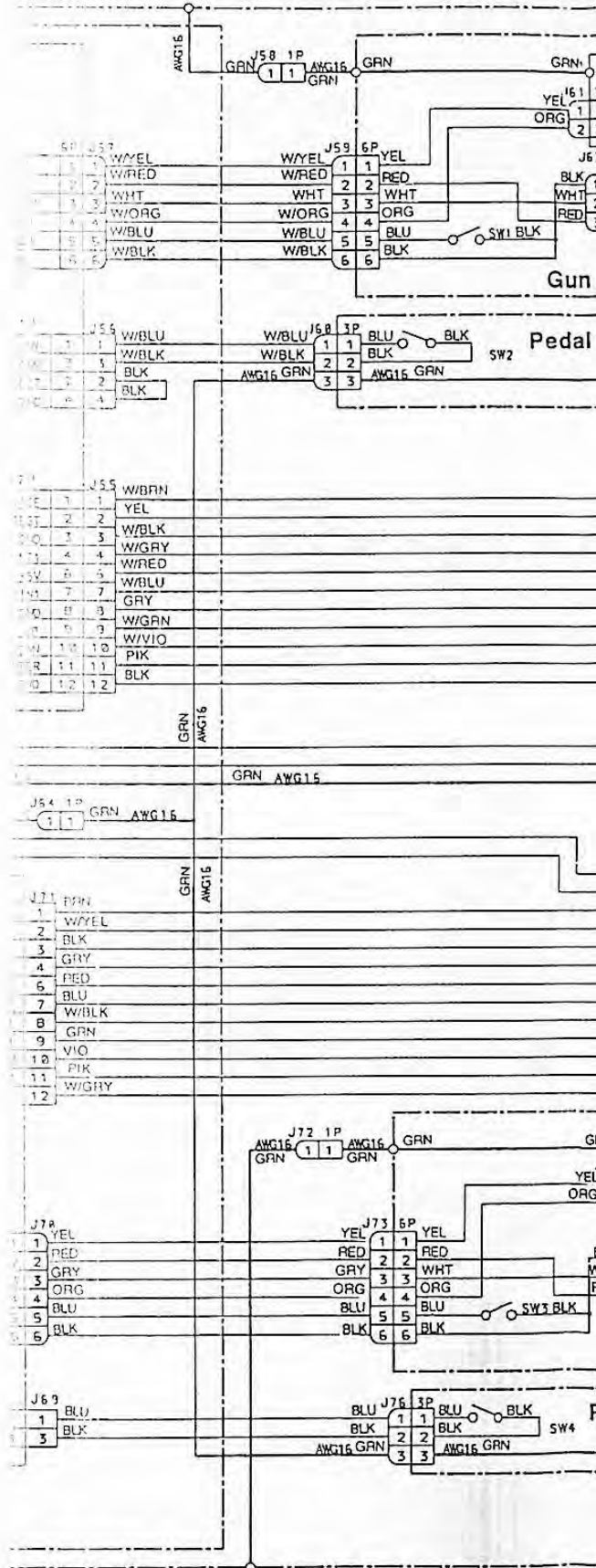

- Notes
1. Use contact for the plug connector and a pin contact for the cap connector.
 2. The connectors are of the miniature universal Mate-n-lock type.
 3. The thin lines represent wire AWG 24. Thick lines represent wire AWG 18.

11. Wiring Diagram

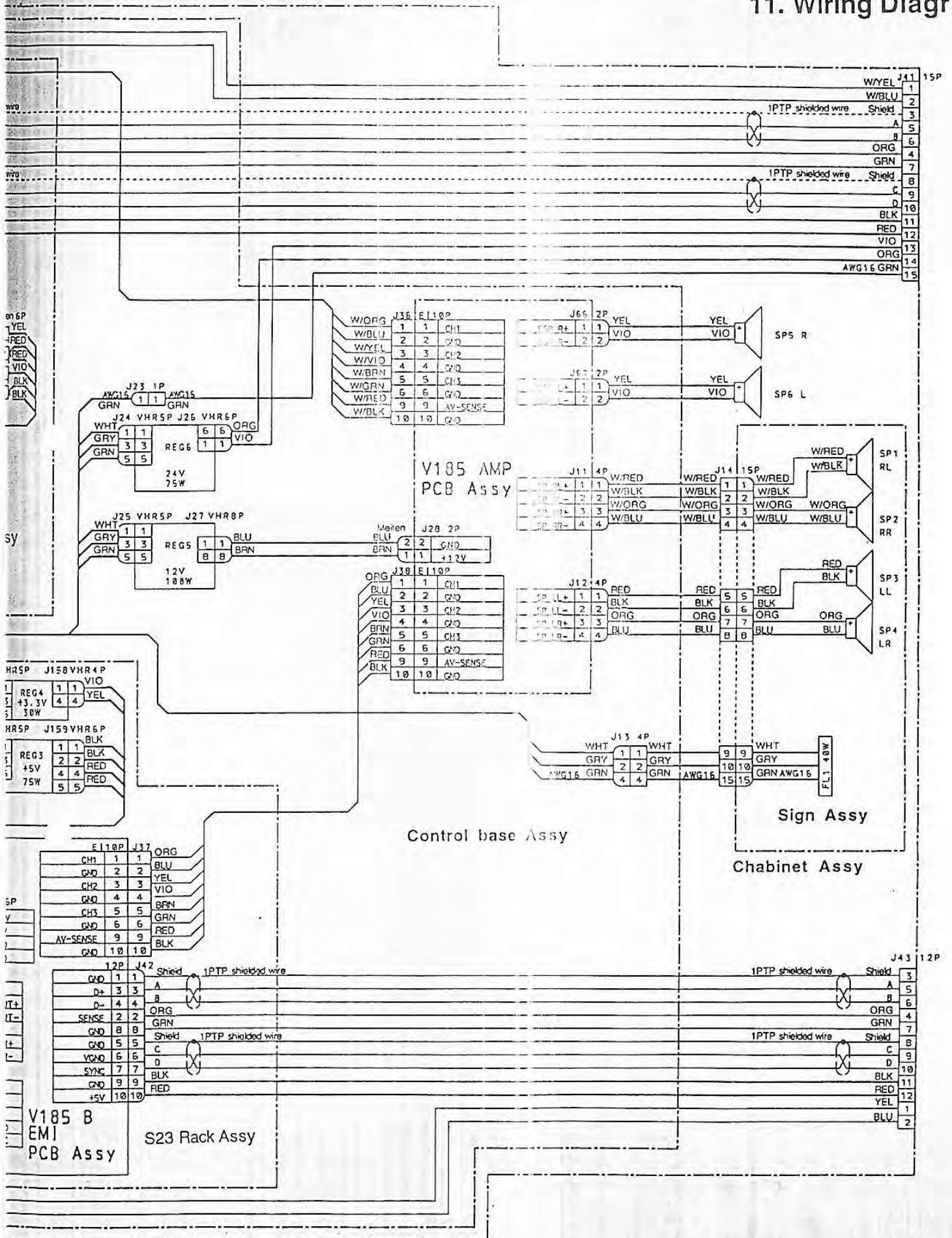

3p connector.
 pe.
 wire AWG 18.

Cabinet Assy

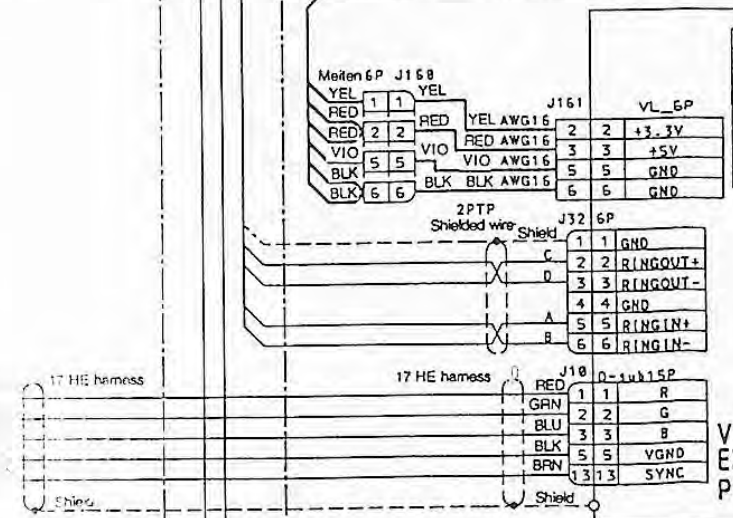
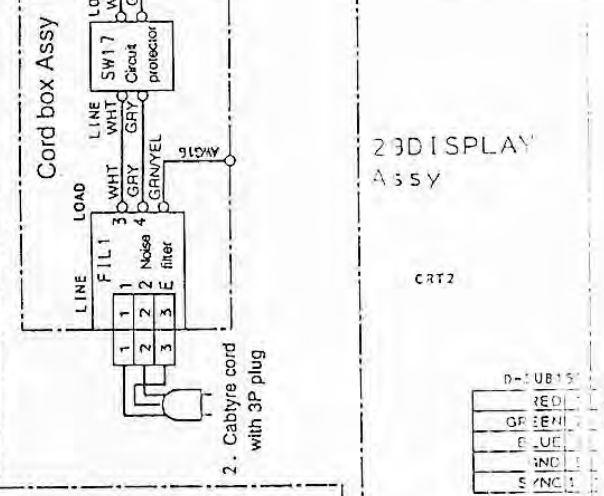
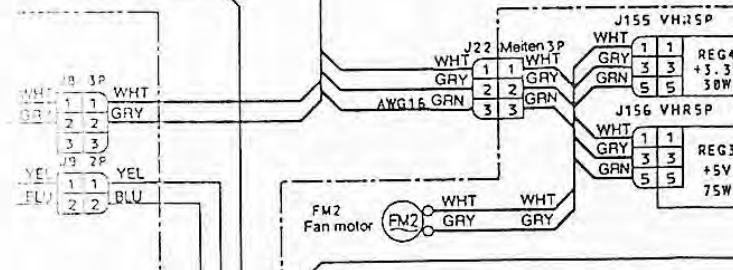
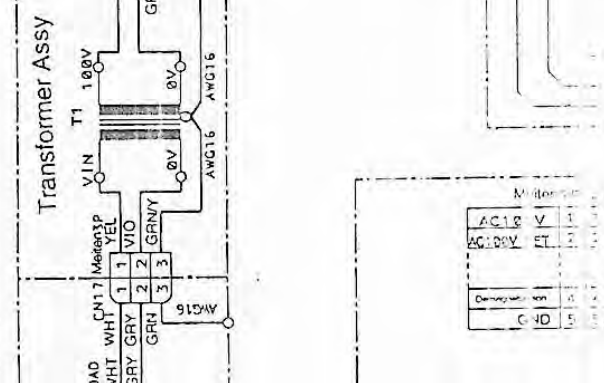
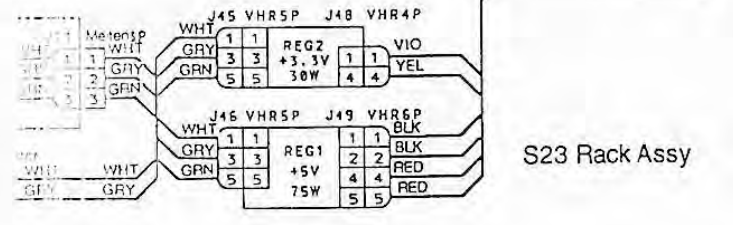
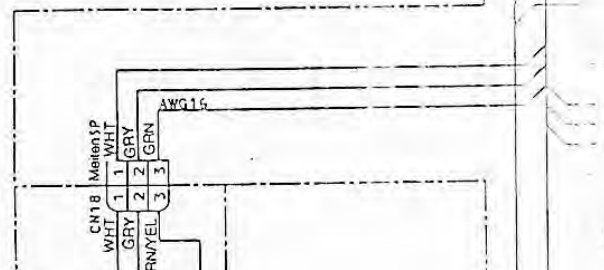
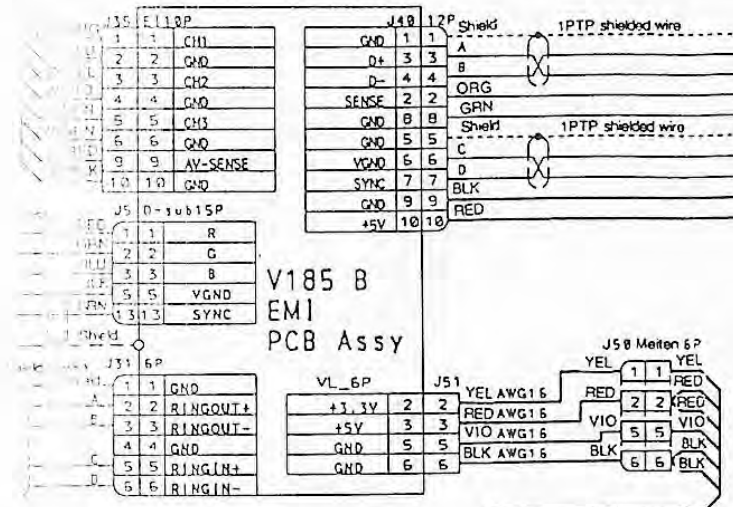
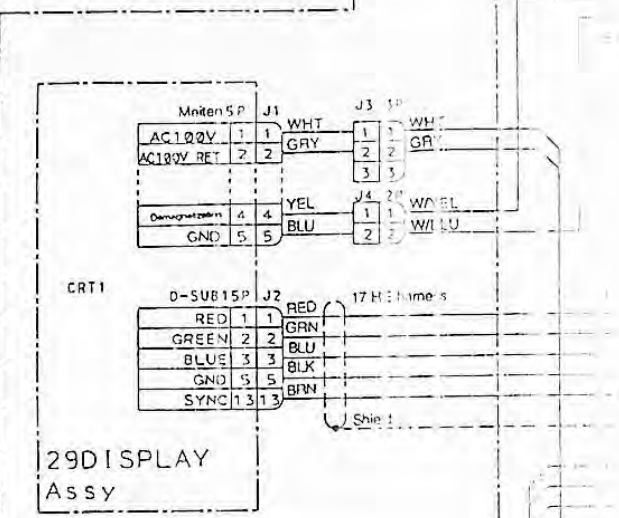

- Notes:
1. Use a socket contact for the plug connector and a pin contact for the cap conn.
 2. The unmarked connectors are of the miniature universal Mate-n-lock type.
 3. The unmarked fine lines represent wire AWG 24. Thick lines represent wire AWG 16.

WARRANTY

Seller warrants that its printed circuit boards and parts thereon are free from defects in materials and workmanship under normal use and service for a period of ninety (90) days from the date of shipment. Seller warrants that its video displays (in games supplied with video displays) are free from defects in material and workmanship under normal use and service for a period of thirty (30) days from the date of shipment. None of the Seller's other products or parts thereof are warranted. Seller's sole liability shall be, at its option, to repair, replace, or credit Buyer's account for such products which are returned to Seller during said warranty period, provided:

- a) Seller is promptly notified in writing upon discovery by Buyer that said products are defective.
- b) Such products are returned prepaid to Seller's plant; and
- c) Seller's examination of said products discloses to Seller's satisfaction that such alleged defects existed and were not caused by accident, misuse, neglect, alteration, improper repair, improper installation, or improper testing.

In no event shall Seller be liable for loss of profits, loss of use, incidental or consequential damages.

Except for any express warranty set forth in a written contract between Seller and Buyer which contract supersedes the terms herein, this warranty is in lieu of all other warranties expressed or implied, including the implied warranties of merchantability and fitness for a particular purpose, and all other obligations or liabilities on the Seller's part, and it neither assumes nor authorizes any other person to assume for the Seller any other liabilities in connection with the sale of products by Seller.

Namco America Inc. distributors are independent, being privately owned and operated. In their judgment they may sell parts or accessories other than Namco America Inc. parts or accessories. Namco America Inc. cannot be responsible for the quality, suitability or safety of any non-Namco America Inc. part or any modification including labor which is performed by such distributor.

SERVICE

If you have questions regarding any Namco America Inc. product or require technical support:

Contact Namco America Inc. Customer Service at:

1 (800) 326-4263 or FAX (408) 232-3060

Hours: 7:00 am - 5:00 pm PDT

Parts and repair services for Namco America Inc. products are available through your distributor.

namcoAmerica Inc.

150 Charcot Ave.

San Jose, CA 95131

(408) 383-3900

FAX: (408) 383-0128

Technical Assistance (USA)

(800) 326-4263

Fax: (408) 232-3060

<http://www.namco.com>

Reorder Number TS45-07702-00

REV. A