

SEGA®

POWER DRIFT

OWNER'S MANUAL



SEGA ENTERPRISES, LTD.

TABLE OF CONTENTS

INTRODUCTION OF THE OWNER'S MANUAL

1. HANDLING PRECAUTIONS	1
2. PREVENTION OF COUNTERFEITING AND CONVERSION	2
3. PRECAUTIONS CONCERNING THE PLACE OF INSTALLATION	3
4. INSTALLATION PRECAUTIONS AND MOVING THE MACHINE	4
5. PARTS NAME	5
6. DISASSEMBLING	6 ~ 8
7. CAUTIONS TO BE TAKEN WHEN TURNING THE POWER ON	9
8. AC UNIT	10
9. GAME POSITION (FORWARD/BACKWARD) ADJUSTMENTS	11 ~ 12
10. REMOVING AND ADJUSTING THE STEERING HANDLE UNIT	13 ~ 14
11. REMOVING THE SHIFT COVER	15
12. REMOVING AND ADJUSTING THE ACCELERATOR/BRAKE	16
13. REMOVING THE VIBRATION UNIT	17
14. REMOVING THE MOTOR UNIT	18
15. ADJUSTING AND REPLACING THE V BELT	19
16. REPLACING THE MOTOR BRUSHES	20
17. ROLLING ADJUSTMENT	21
18. BILLBOARD LAMP REPLACEMENT	22
19. ADJUSTING THE INFRARED SENSORS	23
20. REMOVING THE COIN CHUTE PANEL	24
21. TEST MODE	25 ~ 34
22. DESCRIPTION OF 26 INCH MONITOR	35
23. SERVICE SWITCHES	36
24. DIP SWITCH	37
25. SPECIFICATIONS FOR THE DIFFRENT TYPES OF MOTORS	38
26. EPROM / MASK ROM LOCATIONS	39
27. PARTS LIST	40 ~ 76
28. WIRING DIAGRAM	77 ~ 78

SPECIFICATIONS

- | | |
|----------------------|---|
| • INSTALLATION SPACE | : 2050 mm (80.7in) (L) × 1230 mm (48.4in) (W) |
| • HEIGHT | : 1680 mm (66.1in) |
| • WEIGHT | : 350 kg (772 lbs.) |
| • POWER | : 350 W |
| • C. R. T | : 26 INCH |

NOTE :

Descriptions herein contained may be subject to improvement changes without notice.

INTRODUCTION OF THE OWNER'S MANUAL

SEGA ENTERPRISES, LTD., supported by its high electronic technology of LSIs, microprocessors, etc. and a wealth of experience, has for more than 30 years been supplying various innovative and popular game machines to the world market. This OWNER'S manual is intended to provide detailed comments together with all the necessary information covering the operation in general of electronic assemblies, electromechanicals servicing control, spare parts, etc. as regards the POWER DRIFT a new SEGA product. The manual is intended for those who have knowledge of electricity and technical expertise especially in ICs, CRTs, microprocessors, etc. Carefully read so as to acquire sufficient knowledge before working on the machine. Should there be a malfunction, non-technical personnel should under no circumstance touch the interior system.

1. HANDLING PRECAUTIONS

When installing or inspecting, be very careful of the following points and pay attention to ensure that the player can enjoy the game safely.

- Be sure to turn the power off before working on the machine.
- To insert or pull out the plug quickly is dangerous.
- It is necessary to make sure that the power cord or the grounding wire is not exposed on the road, etc. in a manner so as to be dangerous. Make sure that grounding connections are made safely at the position where so specified.
- Do not use any fuse that does not meet the specified rating.
- Make complete connections for the IC board and other connectors. Insufficient insertion is very dangerous.

Also, for the IC board circuit inspections, only the logic tone is allowed. The use of a tester is not permitted, so be careful in this regard. After confirming that there are no irregularities, turn the power ON.

2. PREVENTION OF COUNTERFEITING AND CONVERSION

LABELLING

To prevent counterfeits and conversions, the following labels are put on all the SEGA products. When handling such goods, be sure to confirm the labels. They are used to prevent illegal acts such as the unauthorized copying of the products and the printed circuit boards thereof or carrying on business by manufacturing similar merchandise or by converting, selling or using such products or printed circuit boards.

ORIGINAL SEAL

The following seal is put on the machines manufactured by SEGA.



LICENSE SEAL

The following seal is put on the kits, such as the printed circuit boards, of SEGA products.



COPYRIGHT NOTICE

This SEGA product has the copyright notice as follows:

© SEGA 1988

This signifies that this work was disclosed in 1988 and is the property of SEGA ENTERPRISES, LTD.

3. PRECAUTIONS CONCERNING THE PLACE OF INSTALLATION

The POWER DRIFT is an indoor game machine. Absolutely do not install it outside. Even indoors, avoid installing in places mentioned below so as to ensure proper usage:

- Places subject to rain or water leakage, or condensation due to humidity.
- In the proximity of an indoor swimming pool and/or shower.
- Places subject to direct sunlight.
- Places subject to heat sources from heating units, etc., or hot air.
- Vicinity of highly inflammable/volatile chemicals or hazardous matter.
- Sloped surfaces.
- Vicinity of anti-disaster facilities such as fire exits and fire extinguishers.
- Places subject to any type of violent impact.
- Dusty places.

PRECAUTIONS FOR INSTALLATION

1. In order to ensure that the customers can enjoy the game safely, providing a guard fence in the periphery of the machine is recommended. Also, accurately perform BEAM SENSOR adjustments and connections. The GUARD FENCE (TX-0023) is an optional part.
2. Make sure that the power supply outlet is used exclusively for the POWER DRIFT. (The outlet's simultaneous use for other machine(s) may cause the breaker to break when the power consumption exceeds the maximum).
3. An extension cord used shall be of a 15A rated current or higher.

The machine's consumption current

Rated current : 2.8 A (100 V AC)

(standby)

Maximum : 10.5 A (100 V AC)

During game play : 2.8 ~ 12 A (100 V AC)

4. INSTALLATION PRECAUTIONS AND MOVING THE MACHINE

INSTALLATION PRECAUTIONS

The machine is equipped with 4 castors and 4 leg adjusters. When the installation position is determined, make sure that there is approximately a 5 mm gap between the floor level and the castors. An insufficient gap may cause the machine to move during game play and result in a dangerous situation.

MOVING THE MACHINE

The machine weighs approximately 350 kg. (772 lbs.), therefore, when moving it on the floor, lift the leg adjusters.

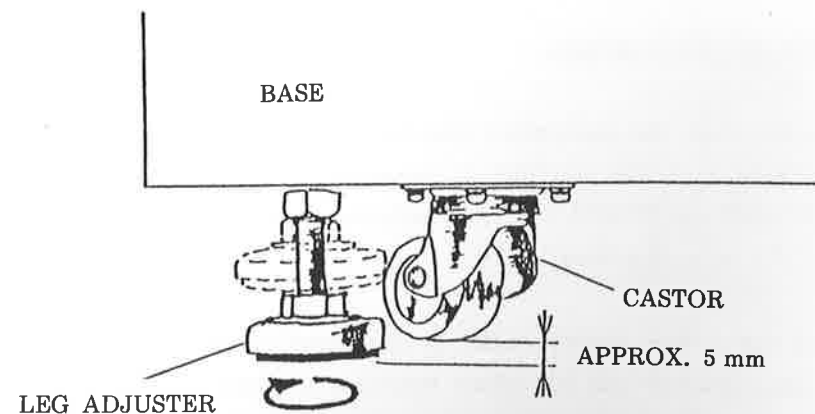

5. PARTS NAME

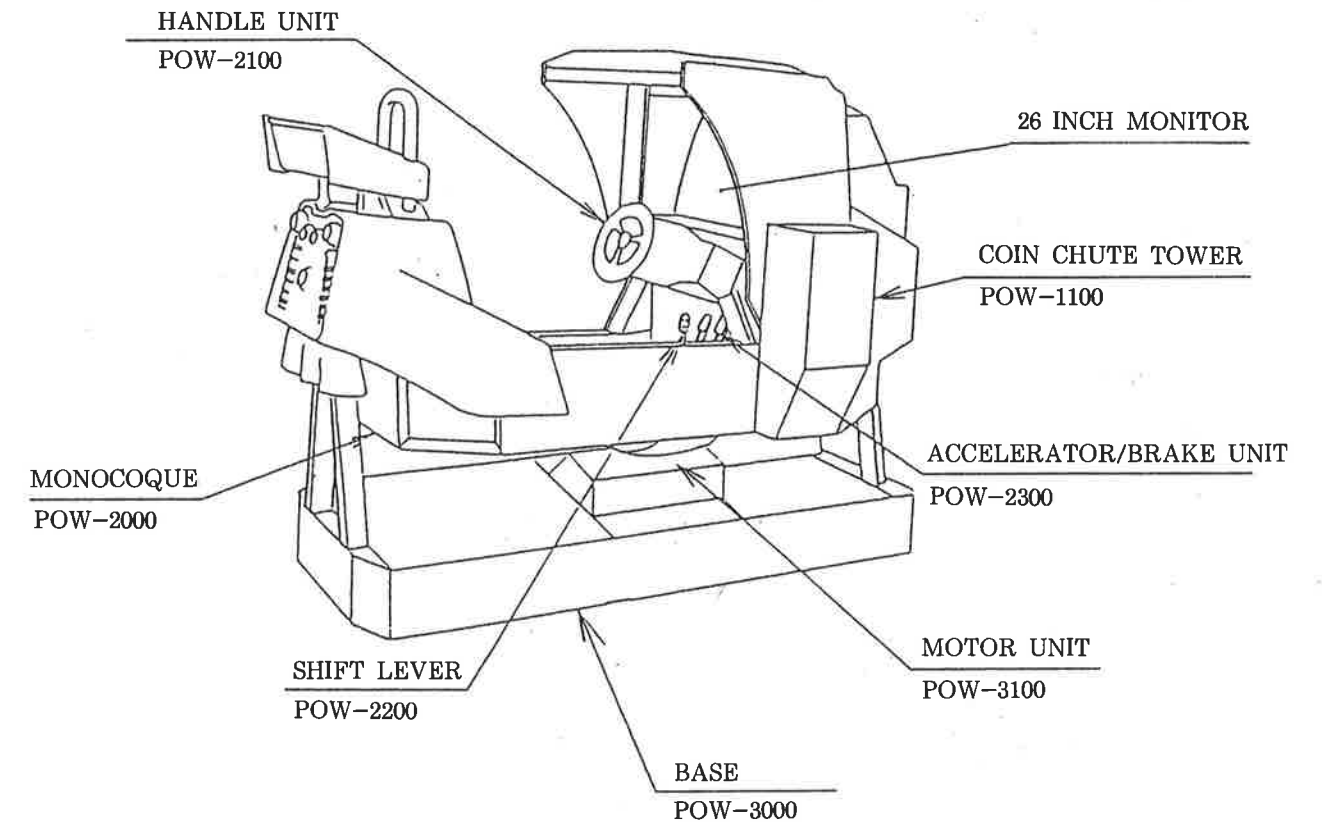

SPARE PARTS

- 220-5130 VOL. CONTROL B 5K Ω (HANDLE UNIT, ACCELERATOR/BRAKE UNIT, MONOCOQUE, ETC.)
- POW-2110 EXT. SPRING (HANDLE UNIT)
- 029-0202 HEX SKT H CAP SCR M6 x 20 (HANDLE UNIT)
- 601-5910 BRUSH FOR MOTOR or 601-6150 BRUSH FOR MOTOR

TOOLS

(TAMPERPROOF WRENCH)

- M4 540-0006-01
- M5 540-0007-01
- M6 540-0015-01

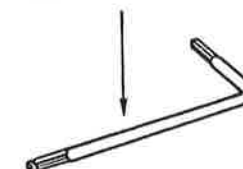

(TAMPERPROOF DRIVER)

- M4 540-0018
- M5 540-0017

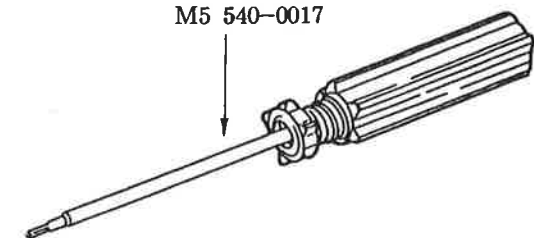

6. DISASSEMBLING

REMOVING THE BASE COVER

The BASE COVER can be removed in the following procedure:

Remove BASE COVER FRONT (POW-3005) by taking off the four M4 TAMPERPROOF SCREWS.

Remove BASE COVER CENTER (POW-3006) by taking off the eight M4 TAMPERPROOF SCREWS.

Remove BASE COVER REAR by using the 2 master keys.

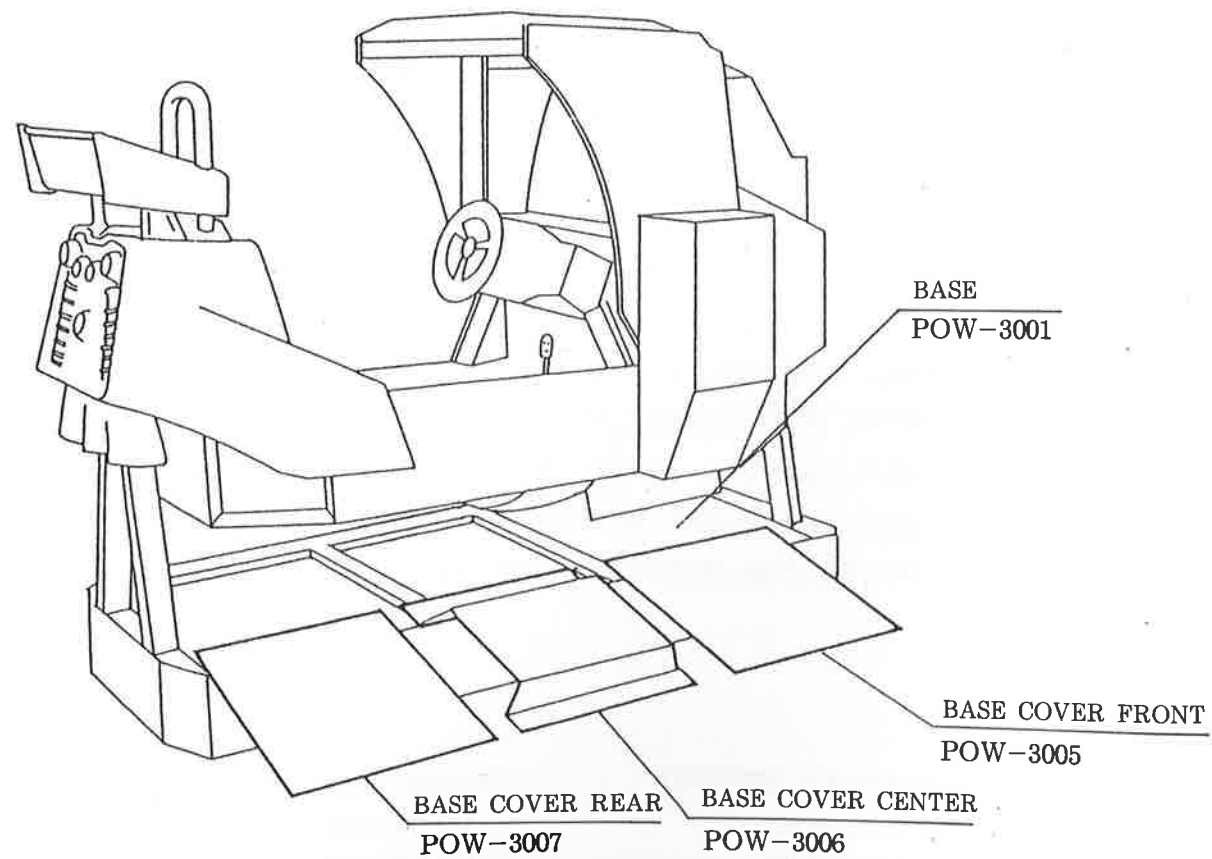

INSTALLING THE STEP

- * Take off the M4 TAMPERPROOF SCREWS and remove BASE COVER CENTER (POW-3006).
- * Install STEP BOX (POW-3004) from the BASE inside by using the M10 BOLTS.
- * After installation, adjust the LEG ADJUSTER.

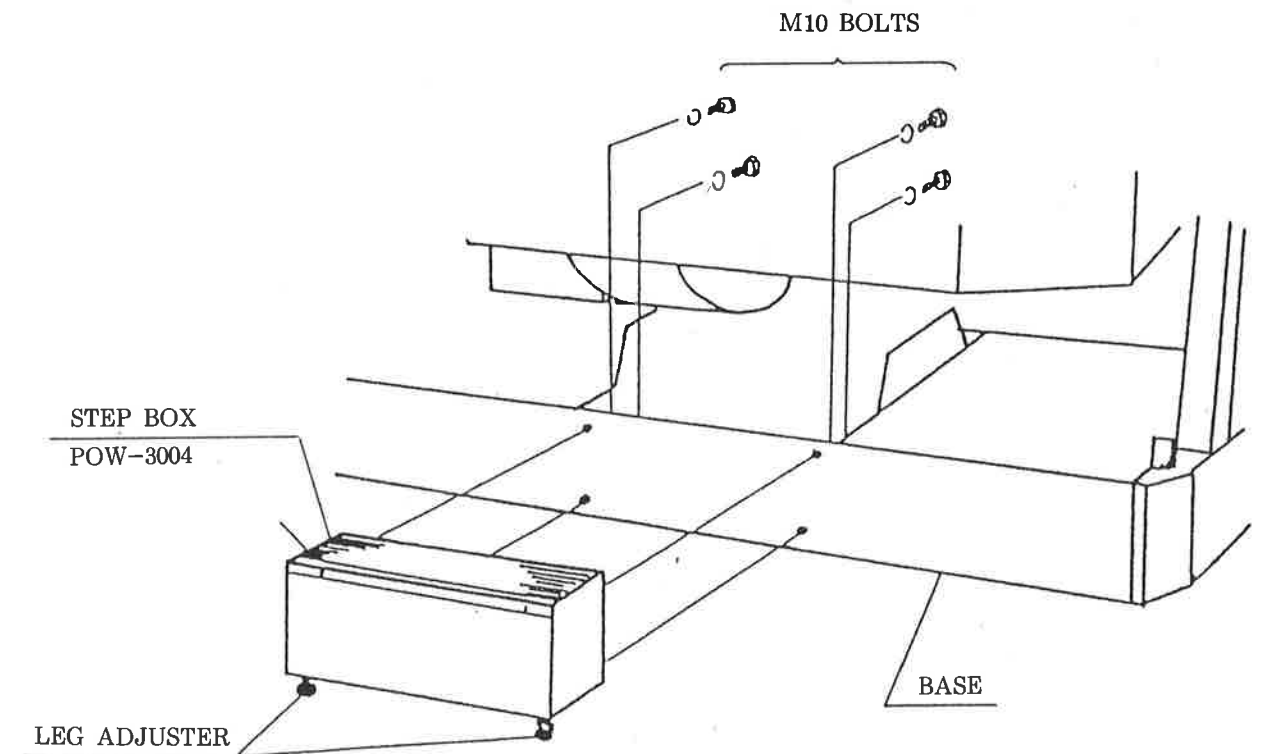

DISASSEMBLING THE COIN CHUTE TOWER

Disassembling the COIN CHUTE TOWER in the following procedure will enable the machine to pass through such narrow places with a width of as little as 90 cm.:

* Take off the M4 TAMPERPROOF SCREWS, remove WIRE COVER B (POW-0009) which is beside the COIN CHUTE TOWER, and take off all the CONNECTORS of CONNECTOR BRACKET C (POW-2024).

o By using the two supplied keys, open the COIN CHUTE DOOR and CASHBOX DOOR, take off the inside M6 BOLT and the M8 NUTS, and remove the COIN CHUTE TOWER.

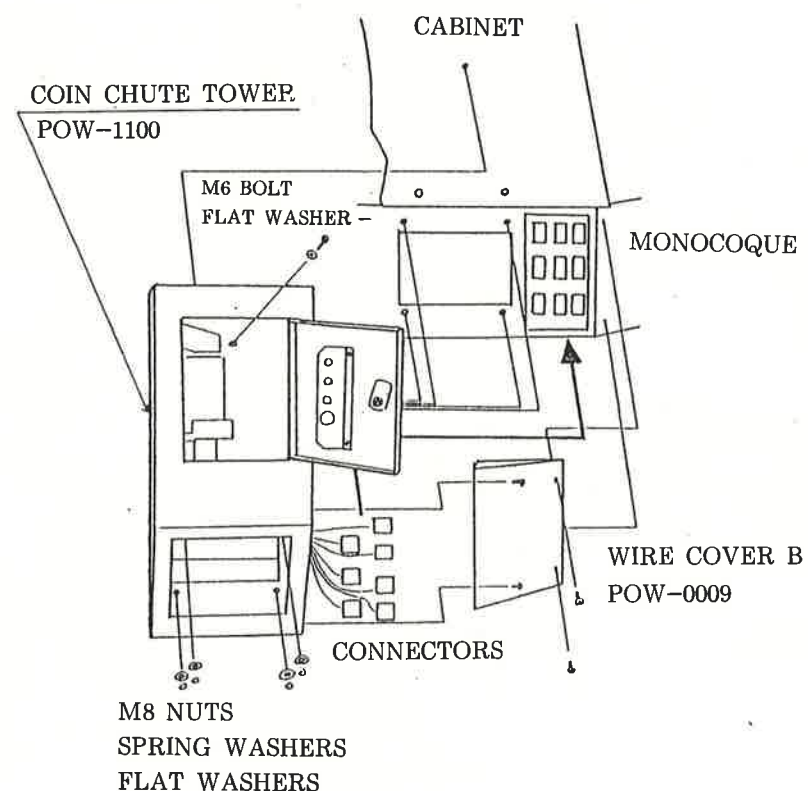

PRECAUTIONS

When installing the COIN CHUTE TOWER, make sure that the color of each of the CONNECTORS is identical with that of the corresponding ones (erroneous wiring not only causes the machine to malfunction, but also is very dangerous, therefore pay particular attention to this point).

7. CAUTIONS TO BE TAKEN WHEN TURNING THE POWER ON

Refrain as much as possible from turning the power ON simultaneously for more than one machine. A drastic decrease in the power supply voltage may cause the machine not to start up properly. When turning the power ON, make sure that there is no obstacles in the machine's mobile range. The cabinet will then perform the function of centering and will be in a state to accept coins.

ACCEPTING THE COINS

The COIN CHUTE TOWER is installed on the cabinet's mobile part (POW-2000).

Therefore, in order to prevent the COIN CHUTE from malfunctioning due to the cabinet's movements, the machine is equipped with a COIN BLOCKER.

The COIN BLOCKER accepts coins only when the cabinet is level against the floor and rejects coins when it is inclined at an angle which exceeds a certain degree.

Also note that when the cabinet's angle detecting V.R. value is not correct, coins may not accurately be inserted even if the COIN BLOCKER is in a state to be able to accept them.

8. AC UNIT

MAIN SWITCH

Turning the MAIN SW ON results in a state of STANDBY.

15A FUSE

Subjecting the machine to an excessive load causes the fuse to blow and the movement of the parts to stop. Replace the fuse after removing the cause.

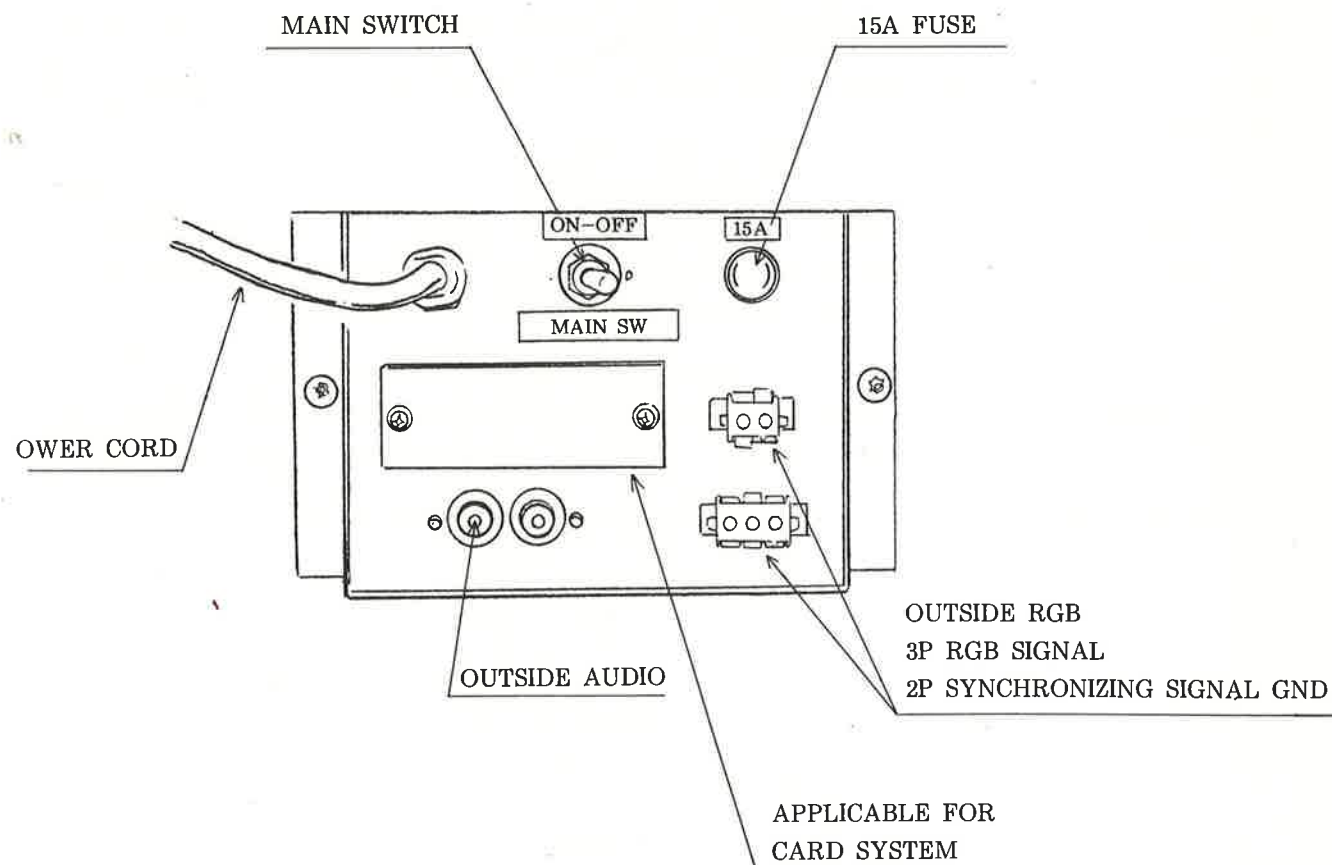

9. GAME POSITION (FORWARD/BACKWARD) ADJUSTMENTS

Adjust the game position by moving the HANDLE and PEDAL forward and backward.

Steering Handle Position Adjustment

- * Take off the M4 TAMPERPROOF SCREW and remove the EMBLEM (HL-2010). Take off the three M6 CAP SCREWS and remove the STEERING HANDLE (KR-1121X).
- * Pull out the COUPLING SPACER (POW-2056), and the STEERING HANDLE will be positioned 20 mm backward (at this time, replace the M6 CAP SCREWS with the spare ones which are shorter).
- * Take off the MOUNT SCREW L (POW-2050), remove the steering BOSS (POW-2004), pull out the BOSS SPACER 20 (POW-2006), and the STEERING HANDLE will be positioned an additional 20 mm backward (at this time, use only one of the two EXTENDERS 20 (POW-2036) which are contained in the STEERING BOSS. Also, replace the MOUNT SCREW with the spare part MOUNT SCREW S (POW-2051).

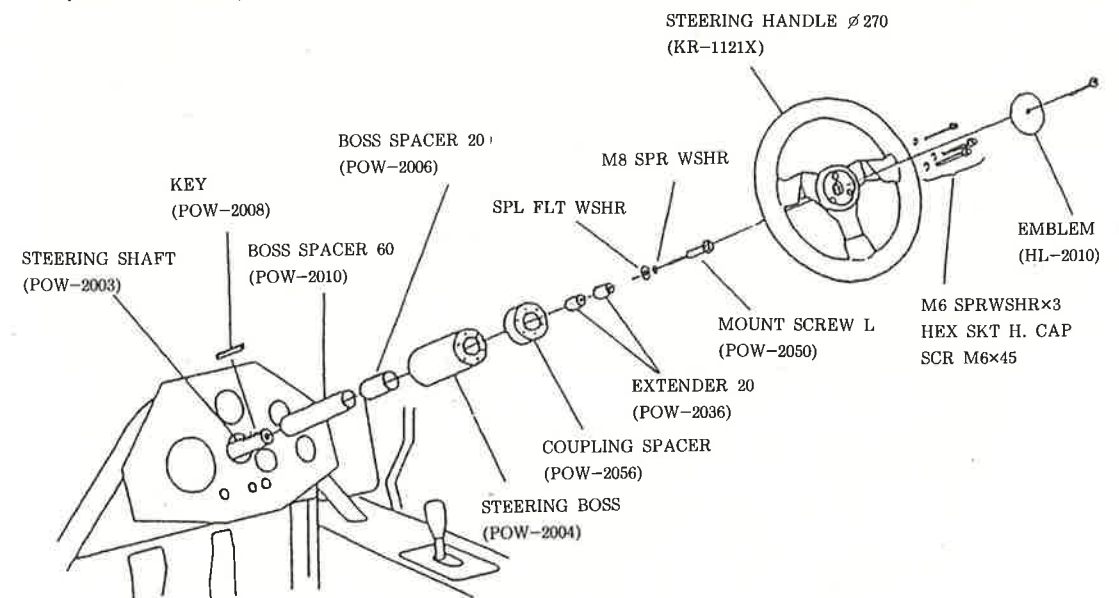

- CAUTION -

The STEERING HANDLE portion tends to be subjected to great shock and thus the screws will easily become loose, therefore, be sure to securely tighten the screws.

Pedal Position Adjustment

- * Peel off the BLIND PLATE (POW-2058) behind the PEDAL (peel off one per step).
- * Take off the M4 TAMPERPROOF SCREWS, remove PEDAL COVER A (POW-2032), take off the M8 BOLT, and the pedal position can be adjusted in 4 steps backward/forward.

- CAUTION -

When changing the pedal position, be careful so as not to catch the wiring.

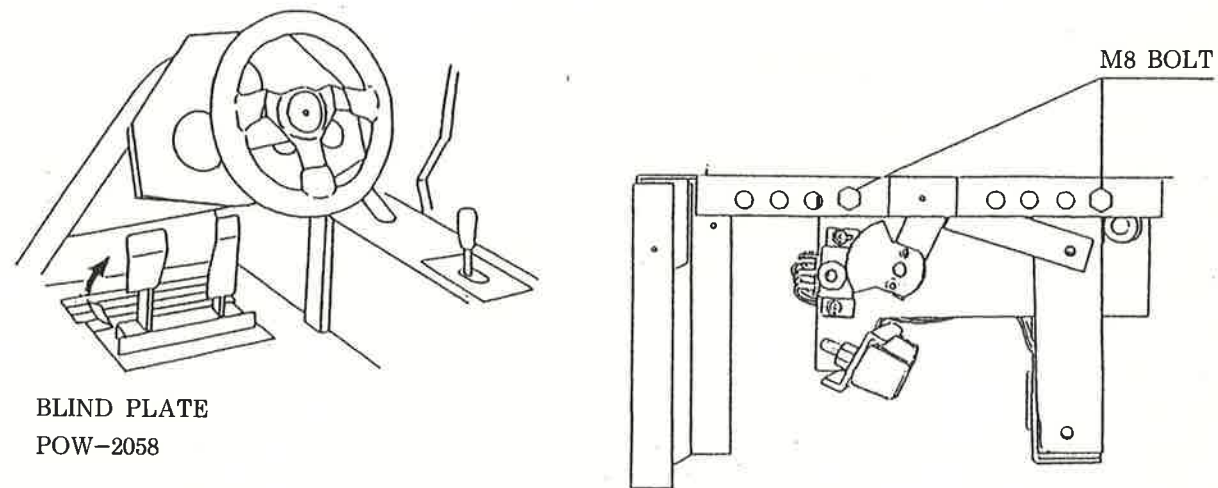

- * Take off the M4 TAMPERPROOF SCREW, remove the FOOTREST EXTENDER (POW-2037), and the PEDAL/FOOTREST positions can be adjusted in 2 steps.

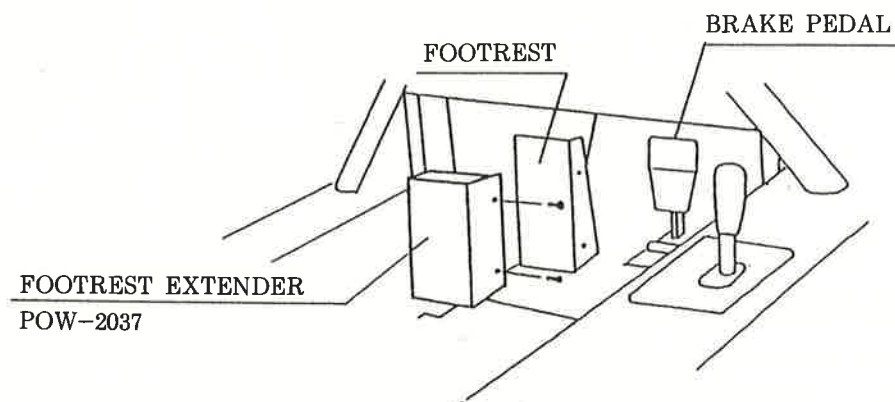

10. REMOVING AND ADJUSTING THE STEERING HANDLE UNIT

When performing the spring replacements and the STEERING HANDLE's centering V.R. adjustments, remove the COVER (POW-2019) by taking off the 4 TAMPERPROOF SCREWS (M4 x 10).

V.R. Adjustments

Adjust the V.R. numerical values in the test mode's INPUT TEST screen.

- ① Loosen SCREW A of the V.R. BRACKET (POW-2111), turn GEAR A and make sure that the on-screen numerical value becomes approximately 80H. When loosening the screw, adjust the gear backlash.
- ② Then loosen the 2 WING BOLTS (M4 x 10), turn GEAR B and make fine adjustments to 80H+1.

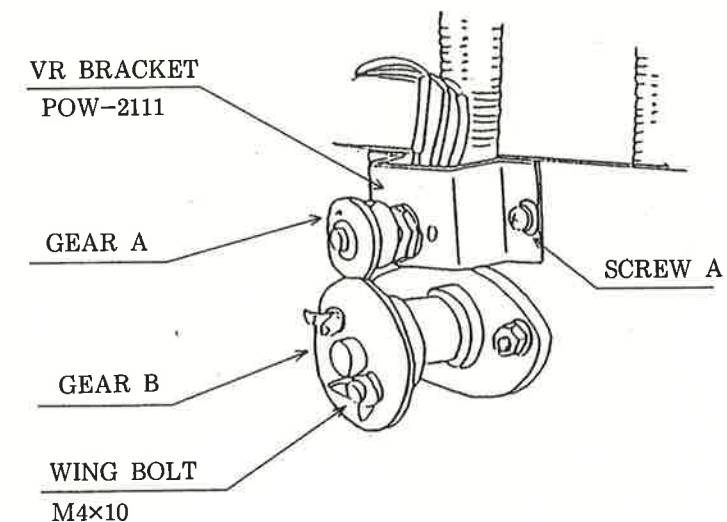
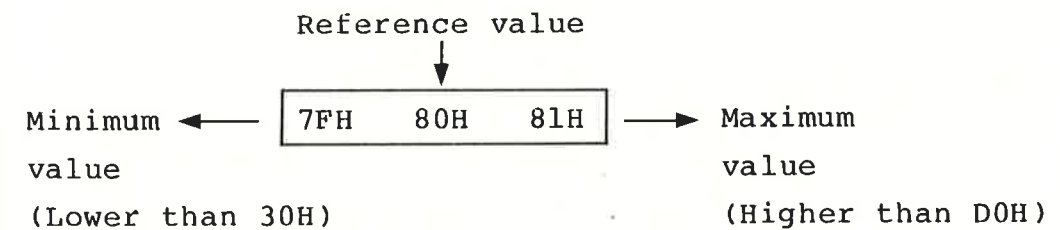

REMOVING THE HANDLE UNIT

Take off the 4 HEXAGON BOLTS (M6 x 20) from the cabinet's front side bottom and remove the HANDLE UNIT.

When assembling it, follow the procedure opposite to the above. At this time, pay attention to the STEERING CENTER POSITION and simultaneously adjust the backlash.

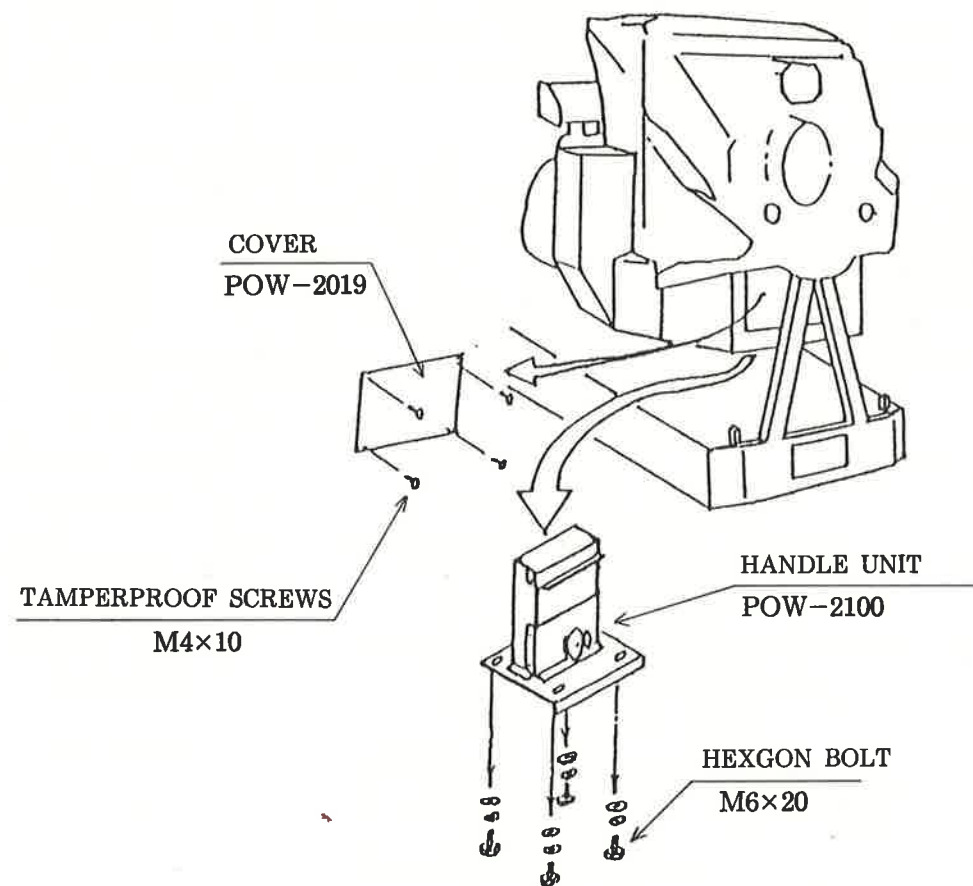

11. REMOVING THE SHIFT COVER

Take off the 4 TAMPERPROOF SCREWS and the DESIGN PLATE (POW-2049).

By using a hexagon wrench (2.5 mm), take off the 4 thin head screws and remove the SHIFT LEVER UNIT.

When assembling it, follow the procedure opposite to the above. At this time, pay attention to the SLIDE PLATE (POW-2211) (put the SLIDE PLATE in the indented portion of the SHIFT LEVER).

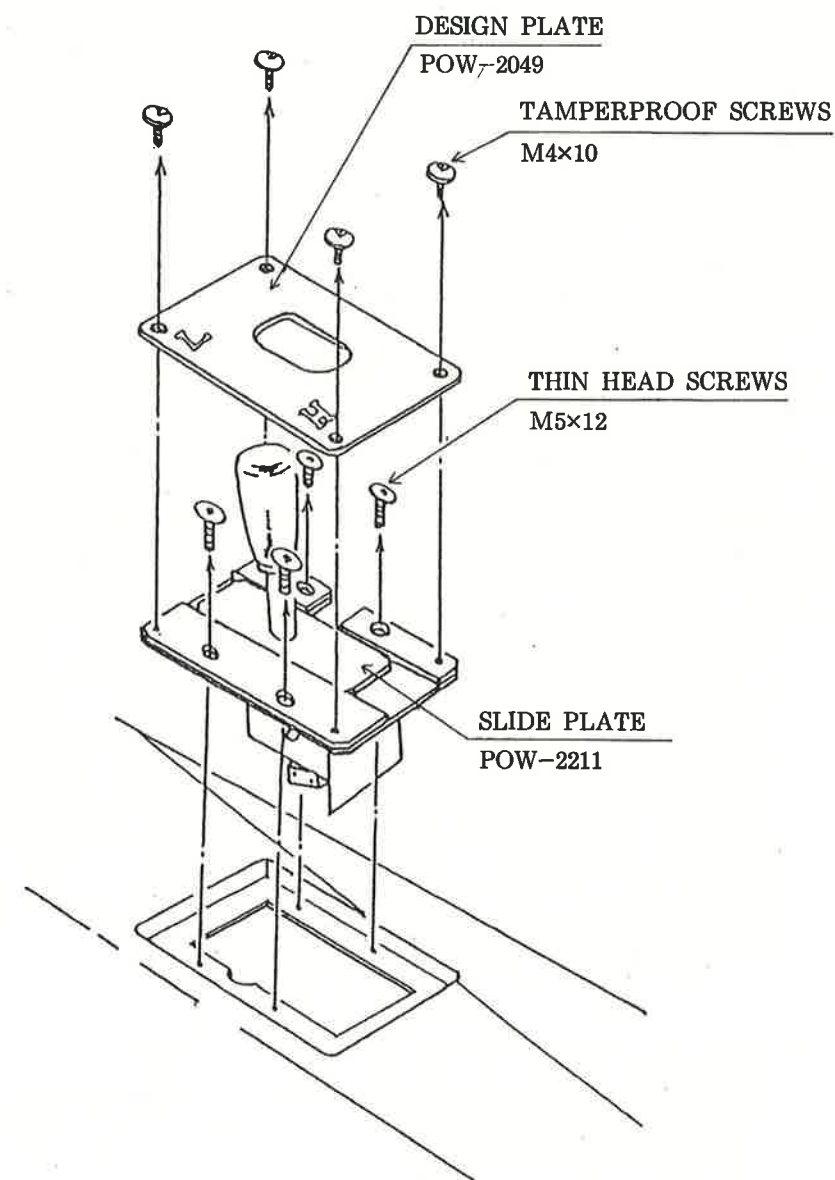

12. REMOVING AND ADJUSTING THE ACCELERATOR/BRAKE

When adjusting the ACCELERATOR/BRAKE, take off the 5 TAMPERPROOF SCREWS (M4 x 10) of the PEDAL COVER (POW-2032) which is on the underside of the cabinet. Also, the ACCELERATOR/BRAKE can be removed from the cabinet by taking off the 4 BOLTS (M8 x 25).

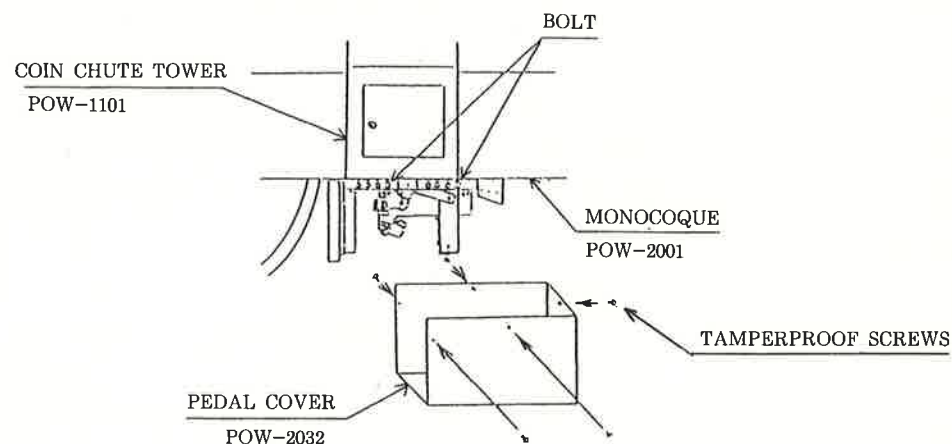

Adjusting the Accelerator/Brake

Make adjustments of the Accelerator/Brake by using the following procedure:

Perform the V.R. numerical adjustments in the test mode's INPUT TEST screen.

- ① Loosen SCREW A of VR BRACKET (POW-2111), turn GEAR A and make sure that the on-screen numerical value becomes approximately 20H. When fastening the screw, adjust the gear backlash.
- ② Then, loosen SCREW B, turn GEAR B and make fine adjustments to 20H+4.

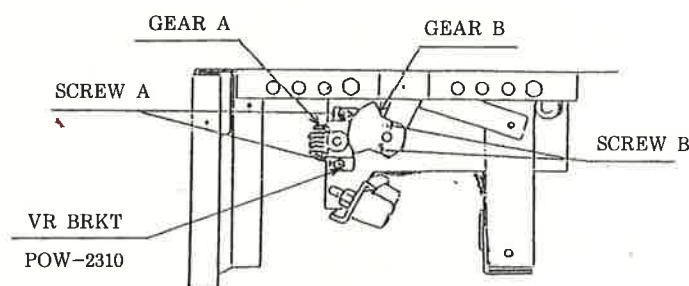

ACCELERATOR	Reference value									Maximum
Minimum	1CH	1DH	1EH	1FH	20H	21H	22H	23H	24H	(C0)
(20)										
BRAKE	Allowable adjustment range									(C0)
(20)										

13. REMOVING THE VIBRATION UNIT

The VIBRATION UNIT is installed on the underside of the MONOCOQUE.

Take off the four M4 TAMPERPROOF SCREWS, remove the VIBRATOR COVER (POW-2044), take off the four M6 SCREWS which secure the unit and slightly move it, disconnect the 2 CONNECTORS, and then remove the unit.

- DANGER -

Before removing the VIBRATION UNIT, be sure to turn the power OFF and confirm that it is in a stationary status.

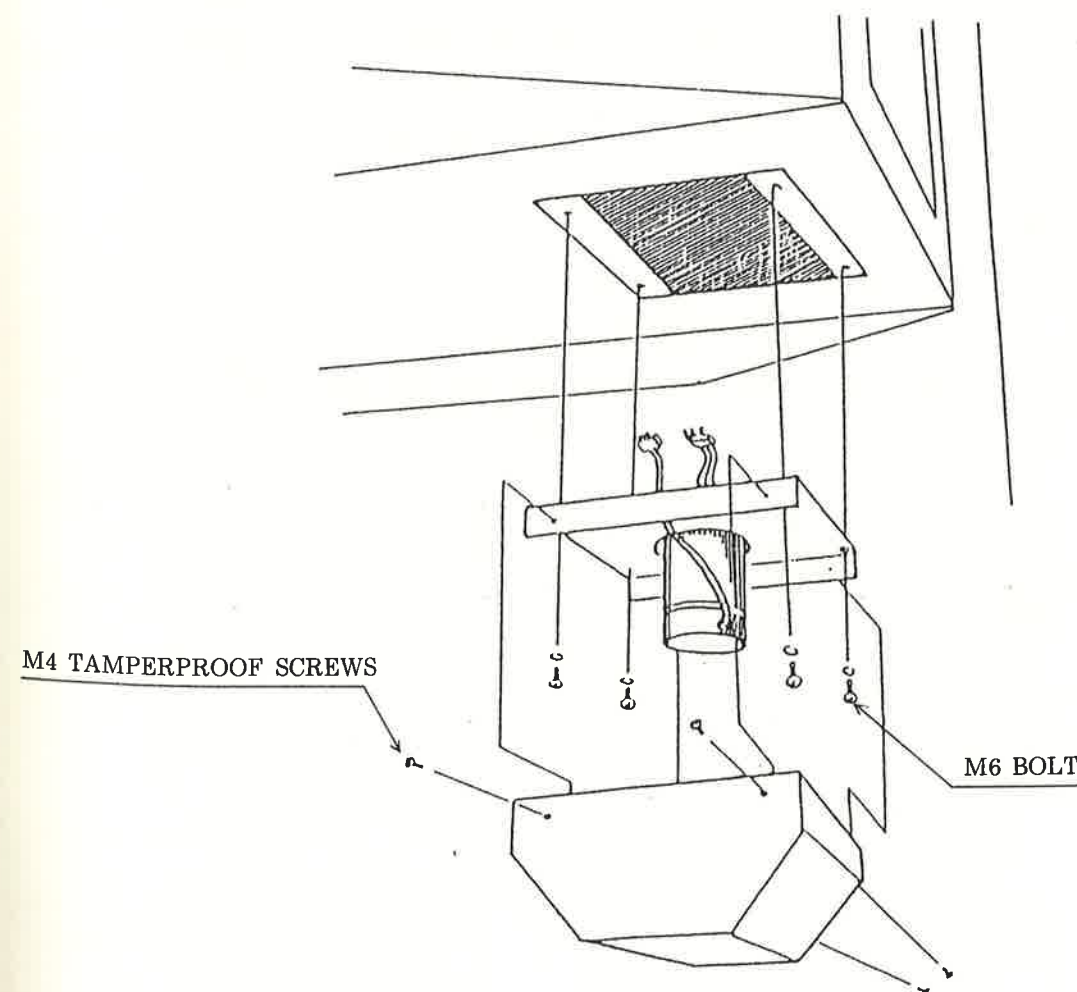

14. REMOVING THE MOTOR UNIT

Remove the MOTOR UNIT in the following procedure:

- * Take off the M4 TAMPERPROOF SCREW and remove BASE COVER CENTER (POW-3006).
- * Disconnect the motor's 2 CONNECTORS.
- * Fasten the supplied BOLT (M10 x 90) in the hole beside the tire in a manner so that the tire is lifted up approximately 7 - 8 mm from the frame.

- CAUTION -

When the tire is raised, the cabinet will, by its dead load, incline to the right. Therefore, pay attention to this point.

- * Take off the M10 BOLTS which secure the bearing that supports the motor unit.
- * Raise the unit and pull it forward.

- DANGER -

When removing the motor unit, be sure to turn the power OFF.

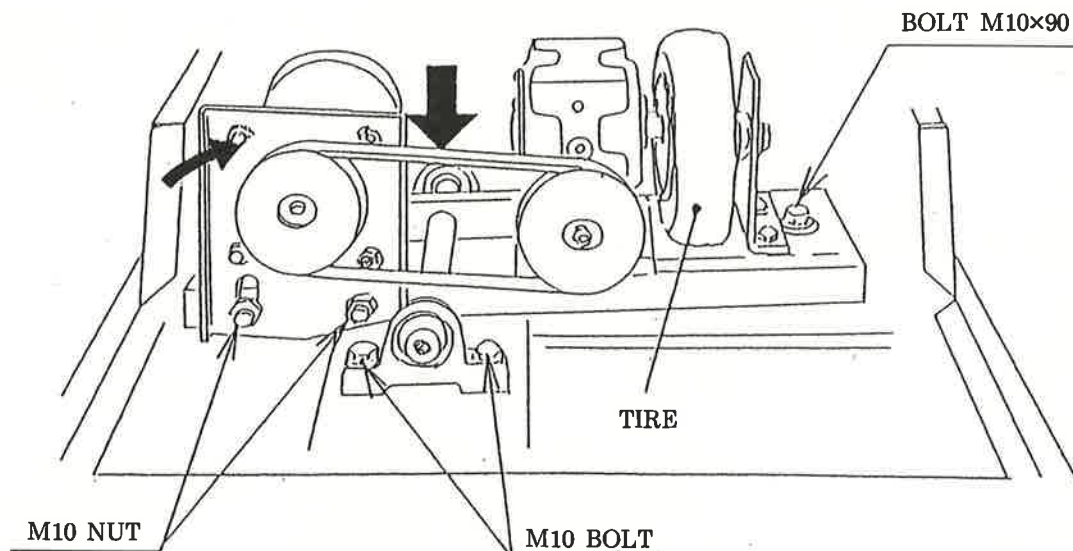

15. ADJUSTING AND REPLACING THE V BELT

When adjusting and replacing the V BELT, loosen the M10 NUTS which secure the MOTOR BRACKET and move the MOTOR BRACKET in the direction of the arrow. Adjust the belt tension by pressing its central portion with your finger in a manner so that there will be a slack of approximately 10 mm.

16. REPLACING THE MOTOR BRUSHES

- (1) Remove the caps by using a driver, etc.
- (2) Take out the brush and replace it.

CAUTION Replace the two brushes simultaneously.

There are two different types of motors. Depending on the one used, the brush to be utilized differs. Confirm the parts number indicated on the motor and be sure to use the appropriate brush.

MOTOR	BRUSH
350 - 5133	601 - 5910
350 - 5134	601 - 6150

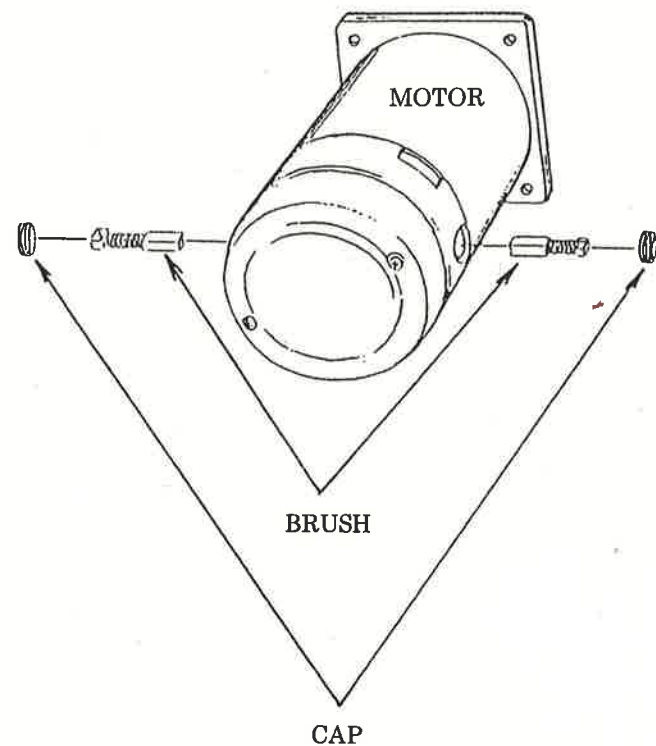

17. ROLLING ADJUSTMENT

Adjust the rolling V.R. in the BANK MOTOR TEST of the TEST MODE screen's MOTOR TEST ITEMS.

- * Move the steering handle to the right/left in a manner so that the cabinet is in a level position.
- * Take off the M4 TAMPERPROOF SCREWS and remove MASK CLEAR (POW-2014).
- * First, make sure that the cabinet is in a level position, loosen SCREW A, move the V.R. BRACKET in the direction of the arrow in a manner so that GEAR A and B can move freely.
- * Manually turn GEAR A and while adjusting the on-screen numerical value to approximately 80H, move the V.R. BRACKET and adjust the backlash.
- * When the on-screen numerical value deviates from 80H, loosen SCREW B, turn GEAR B in the direction of the arrow and make fine adjustments in a manner so that the numerical value becomes 80H(+2H).

- CAUTION -

When the numerical value deviates, the cabinet will stay inclined and cause the coins to become stuck. Therefore, be sure to make accurate adjustments.

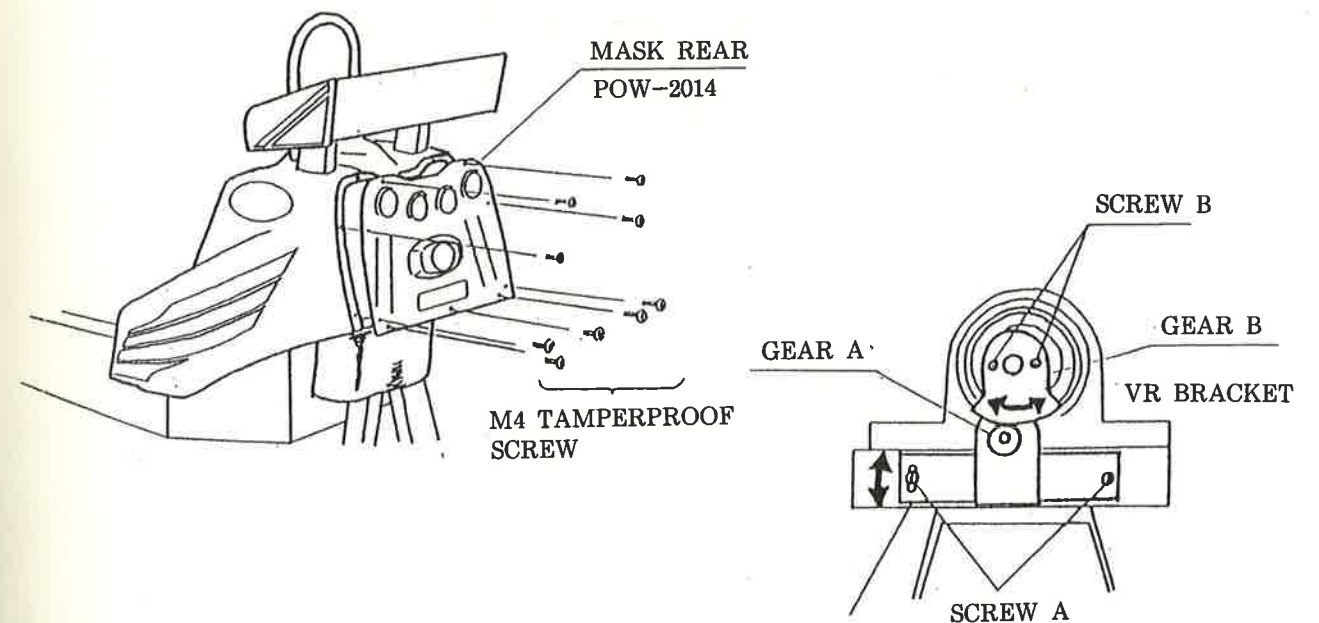

18. BILLBOARD LAMP REPLACEMENT

Take off the six M4 TAMPERPROOF SCREWS, remove the BILLBOARD'S DESIGN PLATE (POW-2402) and replace the BILLBOARD LAMP (use a 15W fluorescent lamp).

- CAUTION -

When replacing the BILLBOARD LAMP, be sure to turn the power "OFF."

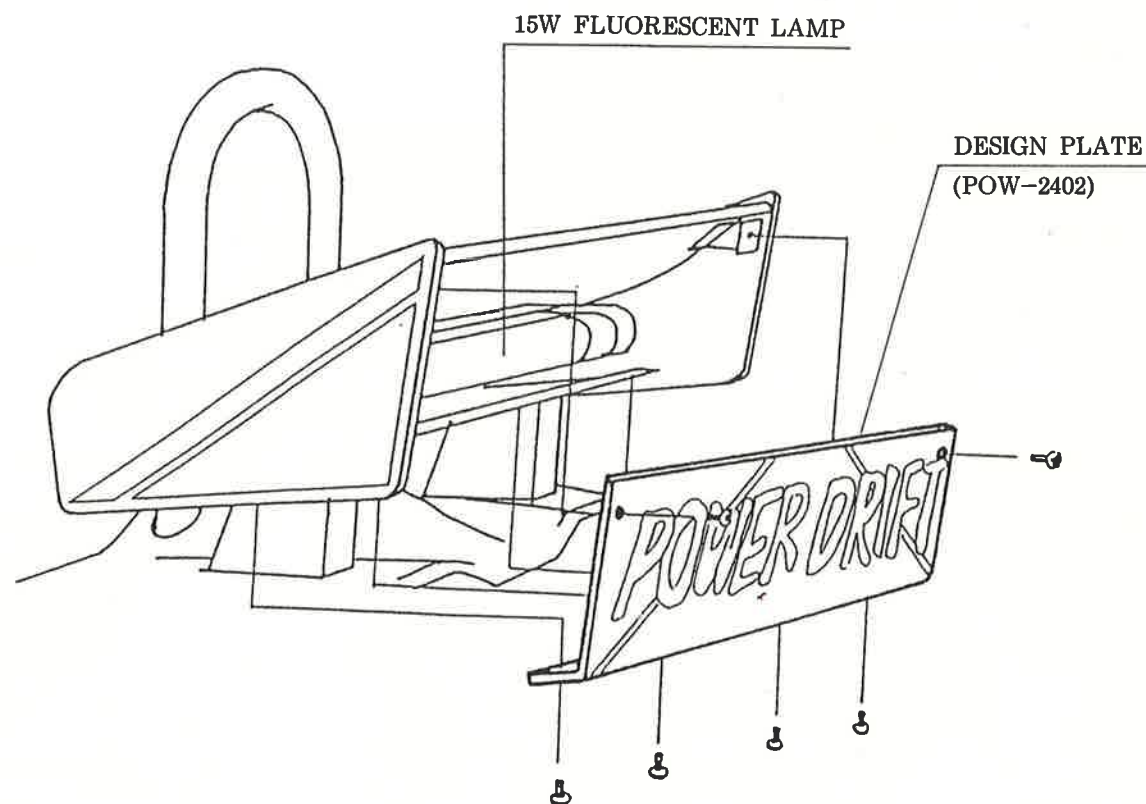

19. ADJUSTING THE INFRARED SENSORS

If any obstacles are in between the sensors, the cabinet stops operating for safety purposes. However, it also stops similarly in the case where the sensor's direction is not correct. Therefore, if the cabinet does not operate even when there is no obstacles in between the sensors, and the red LED lamp within the light receiving sensor continues to light up, the sensor's direction may not be correct. Make adjustments in the following procedure:

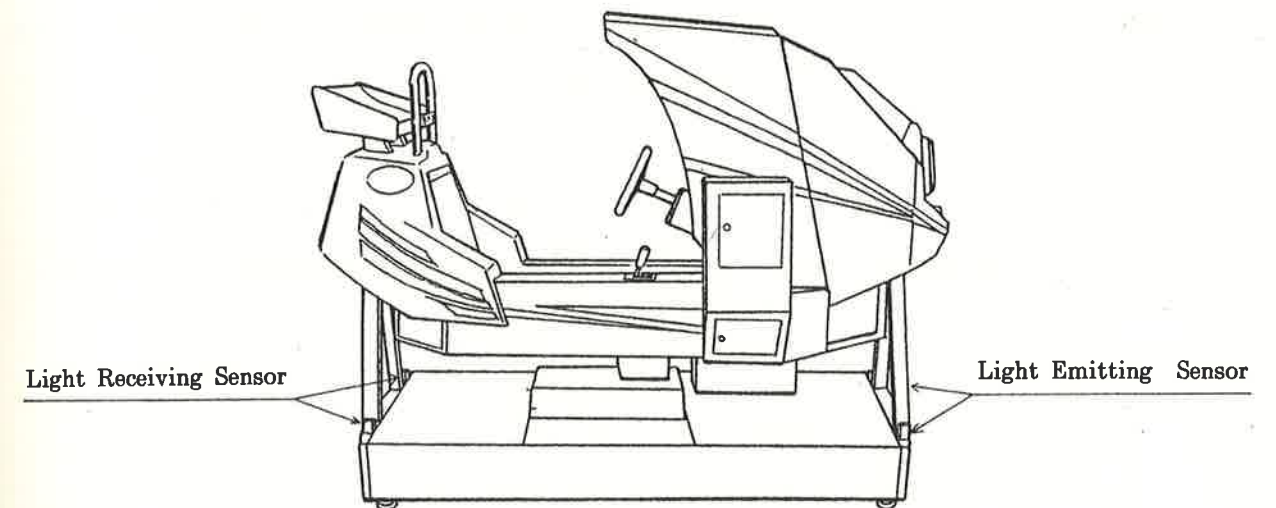

By loosening SCREW A and SCREW B, the UP/DOWN adjustment can be made.

Visually make sure that the sensor's light emitting side and light receiving side faces each other, and make adjustments until the red LED within the light receiving side sensor goes off.

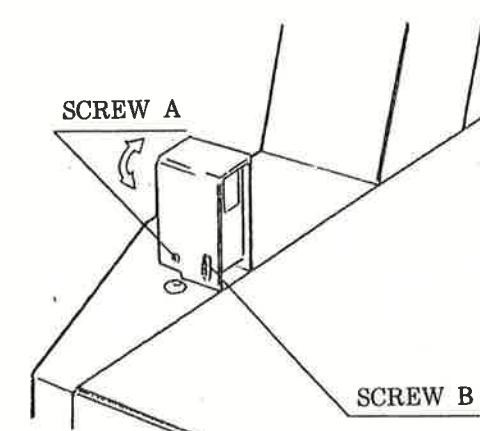

20. REMOVING THE COIN CHUTE PANEL

First, take off WIRE COVER B (POW-0009) which is beside the COIN CHUTE TOWER and disconnect the CONNECTORS (refer to DISASSEMBLING THE COIN CHUTE TOWER).

Open the COIN CHUTE DOOR (POW-1103) and take off the two screws (M4 x 8) which secure the COIN CHUTE PANEL.

Pull the COIN CHUTE PANEL (POW-1102) in the direction of the arrow and remove it towards you. When assembling it, follow the procedure opposite to disassembling.

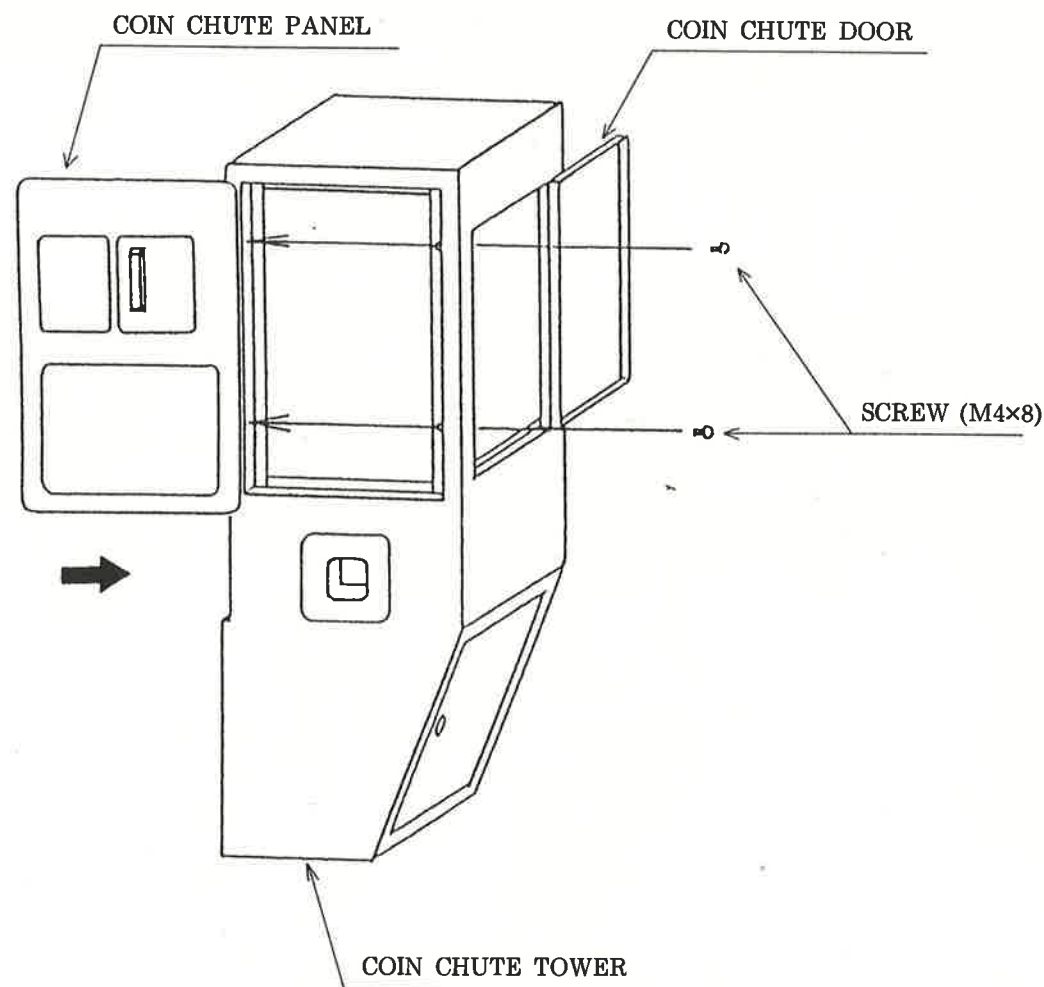

21. TEST MODE

This test mode mainly checks whether the game board correctly operates or if there are any defects, makes monitor color adjustments, and performs sound adjustments.

1. SELECTION OF TEST ITEMS

(1) Push the TEST SW and the following test item menu will be displayed:

```

DIAGNOSTIC VER. 1.00

INDIVIDUAL
MEMORY TEST
INPUT TEST
OUTPUT TEST/
MOTOR TEST
SOUND TEST
C. R. T TEST
DIP SWITCH ASSIGNMENT
BOOKKEEPING
BACKUP RAM CLEAR
※ EXIT
    
```

TEST ITEMS	DESCRIPTION
1. INDIVIDUAL	INDIVIDUAL/CONTINUE mode change.
2. MEMORY TEST	Tests the game board's memory IC's.
3. INPUT TEST	Checks the numerical value of each switch, steering handle, etc.
4. OUTPUT TEST	Checks the "ON" and "OFF" of the START SW LAMP and COIN SOLENOID.
5. MOTOR TEST	Checks the BANK MOTOR and VIBRATION MOTOR.

- 6. SOUND TEST Checks the SOUND ROM and POWER AMPLIFIER.
- 7. C.R.T. TEST Checks the monitor adjustment color bar display.
- 8. DIP SWITCH ASSIGNMENT Displays the DIP SW setting status.
- 9. BOOKKEEPING Displays the records of the number of game plays, game time, etc.
- 10. BACKUP RAM CLEAR ... Clears the records of the number of game plays, game time, etc.
- 11. EXIT Returns to the ordinary game screen.

(2) Turning the steering handle to the right/left will cause the * mark to move upward/down.

Move the desired test item and push the TEST SW.

(3) When the tests are finished, move the * mark to EXIT and push the TEST SW.

2. DESCRIPTION OF EACH TEST ITEM

(1) INDIVIDUAL

With the * mark positioned at INDIVIDUAL, pushing the TEST SW or START BUTTON changes the mode from INDIVIDUAL to CONTINUE. Similarly, with the * mark positioned at CONTINUE, pushing the TEST SW or START BUTTON changes the mode from CONTINUE to INDIVIDUAL.

In the CONTINUE MODE, when a test item is finished, the next test item automatically starts, thus making it convenient when performing all the tests continuously.

(2) MEMORY TEST

This test checks whether the memory IC's on the game board are correct or not.

The indication of "GOOD" means the IC No. is OK. If a memory IC is incorrect, the IC No. will be indicated as "BAD."

```

DIAGNOSTIC VER. 1.00

MEMORY TEST
IC. 24 GOOD IC. 26 GOOD IC. 56 GOOD.....
.....

```

(3) INPUT TEST

Checks the operation of each switch, and the V.R. numerical value of the steering handle, accelerator and brake.

```

DIAGNOSTIC VER. 1.00

INPUT TEST
COIN #1 OFF START OFF ①
COIN #2 OFF SERVICE OFF

LOW GEAR ②

HANDLE RIGHT LEFT 80H ③
ACCEL 20H ④
BRAKE 20H ④

```

- ① Operate each switch. The "ON" indication means that the corresponding SW is OK.
- ② When the shift lever is in a low position, "LOW GEAR" will be indicated and similarly when in a high position, "HIGH GEAR."
- ③ The steering test is OK if the numerical value increases to DOH or higher when it is turned to the right and decreases to 30H or lower when it is turned to the left, and becomes 80H+1 when taking your hand off the steering handle.
- ④ The accelerator/brake test is OK if the numerical value increases to COH or higher when it is applied and becomes 20H+1 when it is not applied.

(4) OUTPUT TEST

Checks the operation of the START LAMP and the OPEN/CLOSE of the coin solenoid which is used to lock in a coin.

```

DIAGNOSTIC VER. 1.00

OUTPUT TEST  *

START LAMP   ON
COIN SOLENOID OPEN
  
```

In accordance with the on-screen display, the ON/OFF of the START LAMP and the OPEN/CLOSE of the SOLENOID will take place in one second cycles, and if not, it is considered to be malfunctioning.

(5) MOTOR TEST

Check the operation of the BANK MOTOR and VIBRATION MOTOR by manually moving them. The test also allows for their self-diagnosis.

1. MOTOR TEST MENU

* To start a desired test, bring the * mark to the test item and push the START BUTTON. When the test is finished, push the START button again.

Note: During the test operation, the motor may suddenly move, therefore, pay careful attention to this point.

```

MOTOR TEST MENU

① BANK MOTOR TEST
② VIBRATION MOTOR TEST
* ③ MOTOR SELF TEST

WARNING! MOVING RIGHT LEFT

PUSH START BUTTON!
  
```

- ① BANK MOTOR TEST Checks the operation of the motor whose function it is to bank the cabinet by using the steering handle. Also, checks the operation of the limit switch and the BANK V.R. numerical value.
- ② VIBRATION MOTOR TEST ... Checks the operation of the VIBRATION MOTOR TEST by using the accelerator.
- ③ MOTOR SELF-TEST A comprehensive self-diagnosis of the motor.

2. BANK MOTOR TEST

Corresponding to the operation of the steering handle, the cabinet moves to the right/left.

BANK MOTOR TEST

MOVE HANDLE RIGHT LEFT
MOTOR VOLUME **H ①
BANK MOTOR ACTIVE

② LIMIT SW RIGHT OFF ③ SAFTY SENSOR RIGHT OFF
LIMIT SW LEFT OFF SAFTY SENSOR LEFT OFF

PUSH TEST BUTTON

- ① The test is OK if the numerical value is 80H+1 when the cabinet position is level.
- ② The test is OK if "ON" is indicated for the LIMIT SW RIGHT/LIMIT SW LEFT when the cabinet fully banks to the right/left.
- ③ When the base's infrared sensor is obstructed, the "ON" indication will be shown.

3. VIBRATION MOTOR TEST

When the accelerator is applied, the motor speed increases.

VIBRATION MOTOR TEST

STEP ON THE ACCELERATOR

VIBRATION LEVEL 0

VIBRATION MOTOR ACTIVE

PUSH START BUTTON

4. MOTOR SELF-TEST

performs the motor's comprehensive self-diagnosis test. This causes the cabinet to move, therefore, keep away from it until the self-test is finished. When the self-test is finished and the results are satisfactory, the following will be displayed:

MOTOR SELF TEST

WARNING! MOVING RIGHT LEFT

MOTOR SELF TEST END

MOTOR SELF TEST OK

PUSH START BUTTON

If there are any malfunctions, "MOTOR SELF-TEST TROUBLE" will be indicated and the following error will be shown below said TROUBLE indication:

1. MOTOR LOCK The motor does not function causing an overcurrent to occur.
2. MOTOR NOT MOVE The motor does not operate because the electric current is not applied.
3. MOTOR SPEED SLOW The motor speed is slower than that specified.
4. ENCODER TROUBLE The encoder which measures the motor speed is malfunctioning.
5. VOLUME ADJ ERROR Incorrect adjustment of BANK V.R.
6. LIMIT SW TROUBLE Incorrect limit switch adjustment.
7. VIBRATION MOTOR TROUBLE The VIBRATION MOTOR is malfunctioning.

(6) SOUND TEST

Only the sound can be manually outputted. Checks sound ROM, sound circuit and the operation of the power amplifier.

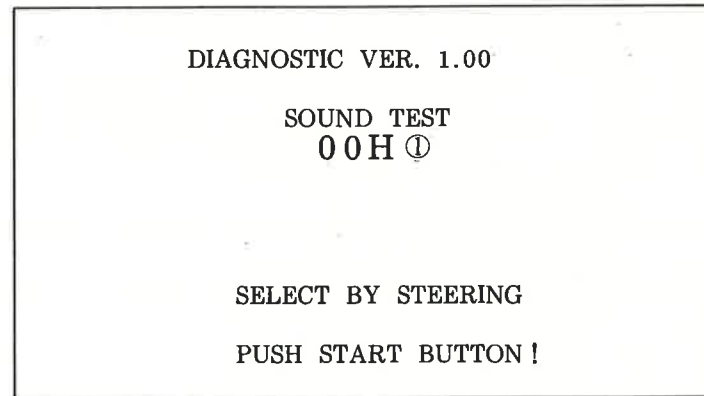

① Turning the steering handle to the right/left results in increasing/decreasing the numerical value of the sound No. Stop the steering handle at the desired number, push the START button, and that number's sound will be emitted. For the sound numbers and the description thereof, refer to the following table:

Sound No.	Description
00H - 3FH	Engine sound
61H - 8DH	Effects
90H - 97H	B · G · M
99H - 9DH	FM effects
A0H - C3H	VOICE
FFH	ALL SOUNDS OFF

(7) C.R.T. TEST

The monitor adjustment color bar is indicated.

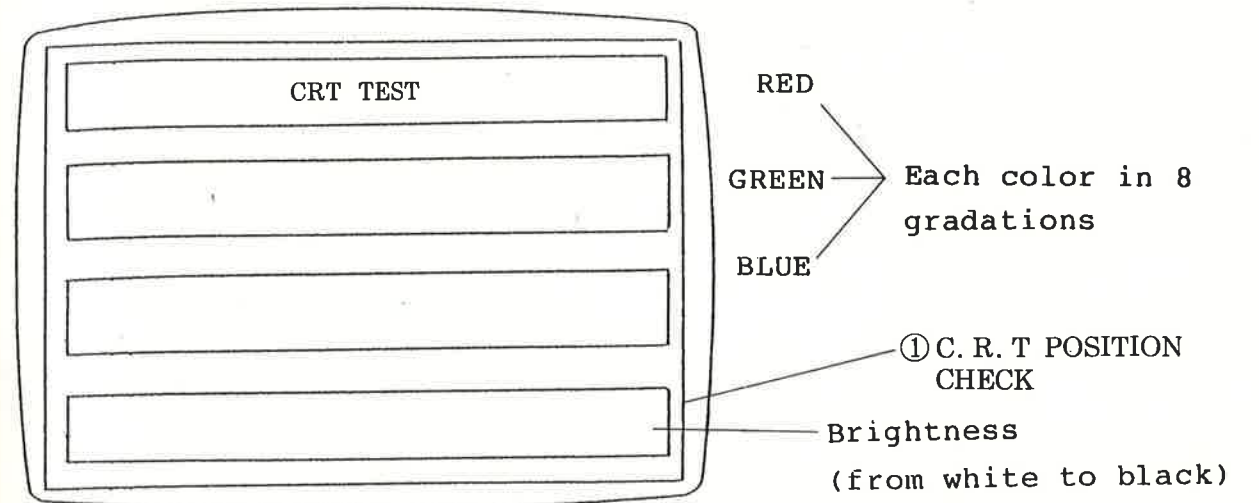

① Adjust the screen's position and size by performing the C.R.T. POSITION CHECK.

(8) DIP SWITCH ASSIGNMENT

Displays the present setting status of DIP SWITCH A & B. For the function of each switch, refer to 24. DIP SWITCHES.

DIAGNOSTIC VER. 1.00	
DIP SWITCH ASSIGNMENT	
	1 2 3 4 5 6 7 8
DIP SW A.	OFF OFF OFF OFF OFF OFF OFF OFF
DIP SW B.	OFF OFF ON OFF OFF OFF OFF OFF
A 1234	COIN SW #1
A 5678	COIN SW #2
B 12	CABINET TYPE
B 3	ADVERTISE SOUND
B 4	EVER OFF
B 5	INITIAL CREDIT
B 6	CONTINUE GAME
B 78	GAME DEFFICALTY
	1 COIN 1 CREDIT
	1 COIN 1 CREDIT
	MOVING
	ON
	2 CREDIT
	YES
	NORMAL

(9) BOOKKEEPING

Displays the records of the number of game plays, game time, etc. Push the START button to proceed to the next screen.

```

DIAGNOSTIC VER. 1.00

BOOK KEEPING

COIN CHUTE #1    **①
COIN CHUTE #2    **②
COIN CREDITS     **③
SERVICE CREDITS **④
TOTAL CREDITS    ***⑤

TOTAL TIME **H **M **S⑥

PUSH START BUTTON
    
```

```

DIAGNOSTIC VER. 1.00

NUMBER OF GAMES ***⑦
CONTINUE        ***⑧

AVE. SCORE      *****⑦
TOP SCORE       *****⑩
LOW SCORE       *****⑪

** GAME TIME **
TOTAL           **H **M *S⑫
AVERAGE        **H **M *S⑬
LONGEST         **H **M *S⑭

PUSH START BUTTON
    
```

(10) BACK UP RAM CLEAR

```

DIAGNOSTIC VER. 1.00

BACK UP RAM CLEAR

* NO
  YES

SELECT BY STEERING

PUSH TEST BUTTON
    
```

Description of Numbers

- ① Number of coins put in COIN CHUTE 1
- ② Number of coins put in COIN CHUTE 2
- ③ Total credits of COIN CHUTE 1 & 2
- ④ Service switch credits
- ⑤ Total credits of ③ and ④
- ⑥ Total time during which the power was "ON"
- ⑦ Number of game plays (including CONTINUE)
- ⑧ Number of CONTINUE plays out of ⑦ above
- ⑨ Average score
- ⑩ High score
- ⑪ Lowest score
- ⑫ Time during which game was played (out of ⑥ above)
- ⑬ Average game time
- ⑭ Longest game time

All the BOOKKEEPING contents can be cleared. When doing so, bring the * mark to YES and push the TEST button. When not clearing, bring the * mark to NO and push the TEST button.

22. DESCRIPTION OF 26 INCH MONITOR

26 INCH MONITOR (NANAO)
(200-5112-15)

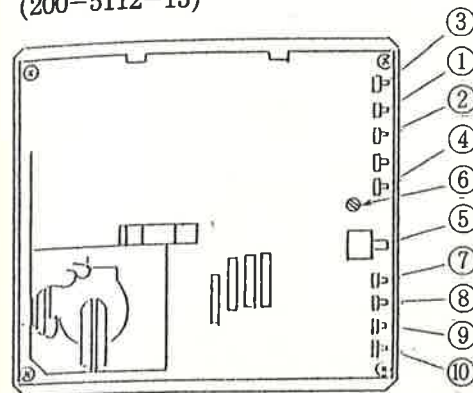

26 INCH MONITOR (SANWA)
(200-5125-15)

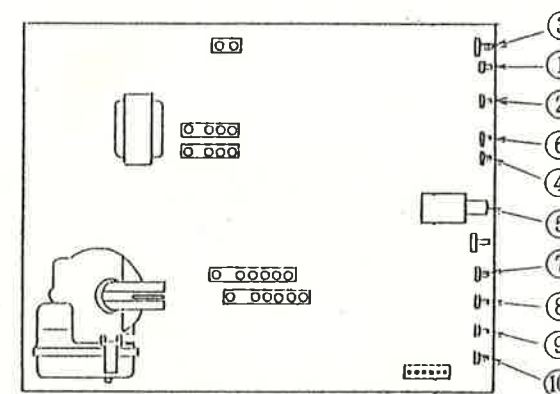

- ① V. HOLD (Vertical synchronizing adjustment)
Allows the on-screen image's vertical distortion to be adjusted.
- ② V. SIZE (Vertical size adjustment)
Adjusts the screens vertical size.
- ③ V. POSI (Vertical position adjustment)
Adjusts the image's vertical position.
- ④ H. HOLD (Horizontal synchronizing adjustment)
Makes adjustments when correcting horizontal distortions.
- ⑤ H. SIZE (Horizontal size adjustment)
Makes adjustments when the horizontal size is too wide or too narrow. When adjusting, use a hexagon driver.
- ⑥ H. POSITION (Horizontal position adjustment)
Allows the image's horizontal position to be adjusted.
- ⑦ BRIGHT
Allows the image's brightness to be adjusted.
- ⑧ B. GAIN
Allows blue color contrast to be adjusted.
- ⑨ G. GAIN
Allows green color contrast to be adjusted.
- ⑩ R. GAIN
Allows red color contrast to be adjusted.

23. SERVICE SWITCHES

Open the COIN CHUTE DOOR, and the following SERVICE SWITCHES' layout will appear:

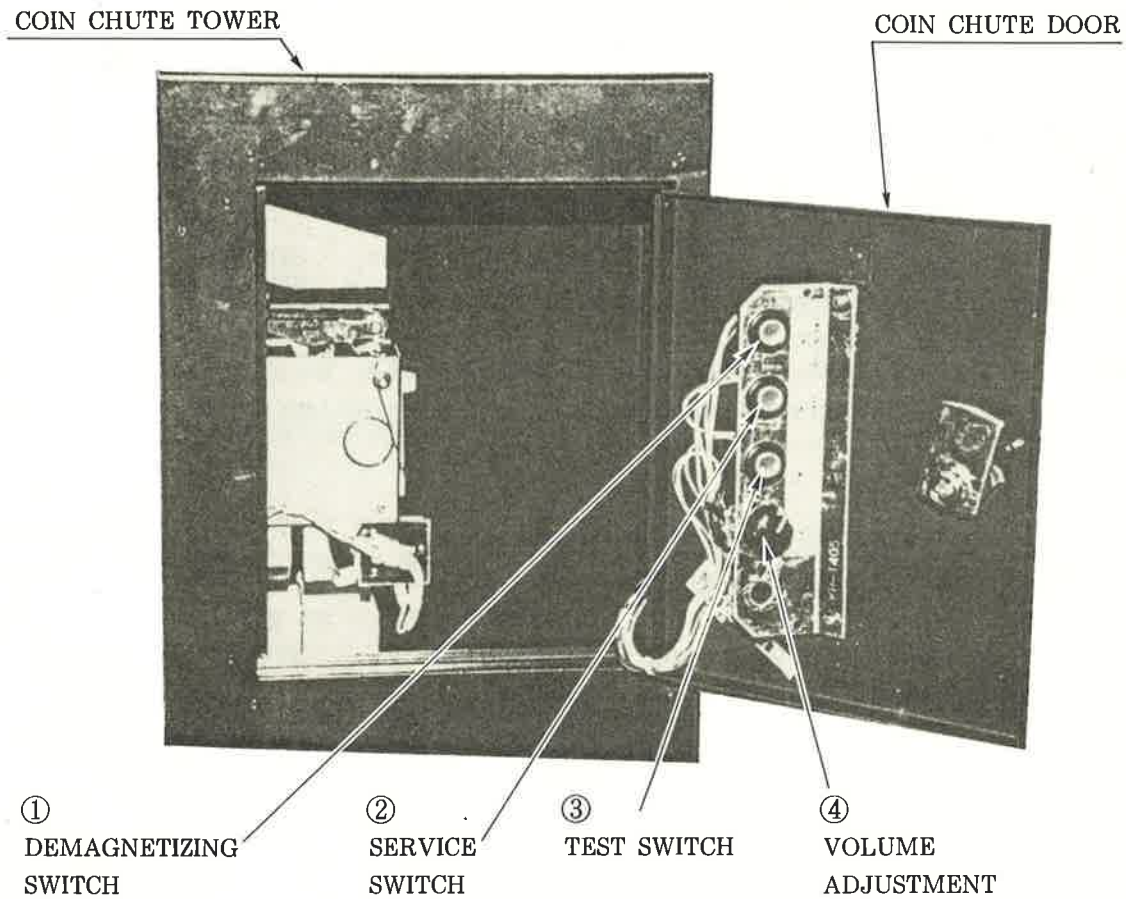

INSTRUCTIONS

- ① DEMAGNETIZING SWITCH Used for removing the on-screen color unevenness.
- ② SERVICE SWITCH Used for the purpose of servicing and increasing the credits without registering on the meter (this allows you to check the game).
- ③ TEST SWITCH For the operation of this switch, see SELF-TEST.
- ④ VOLUME ADJUSTMENT Used for adjusting the volume of the speaker.

24. DIP SWITCH

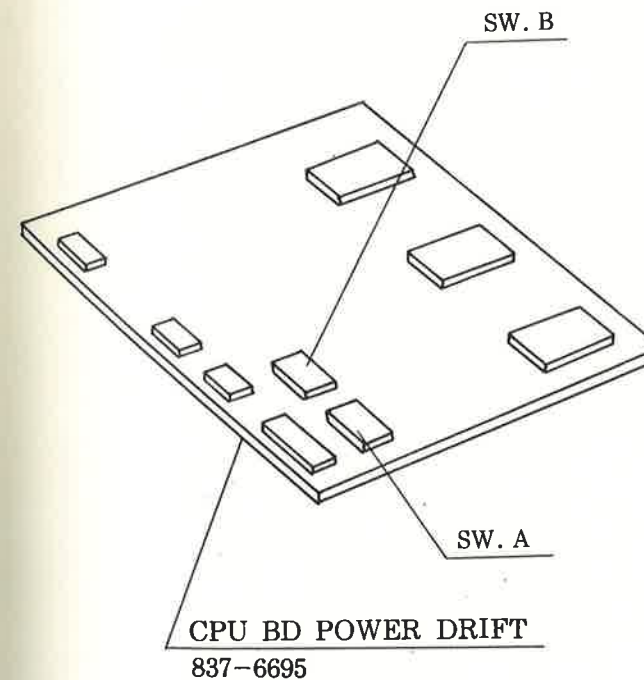
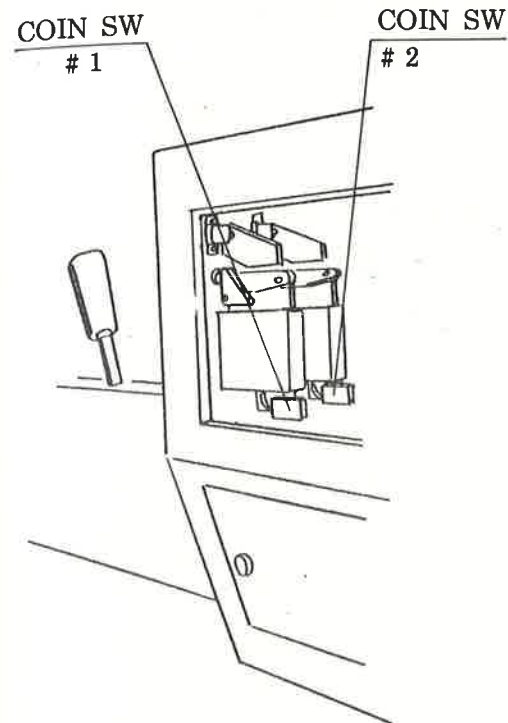

COIN/CREDIT OPTION SWITCH SETTING DIP SWITCH A

DIP SWITCH A								GAME PRICE SETTING.	
1	2	3	4	5	6	7	8	1 COIN	1 CREDIT
OFF	OFF	OFF	OFF	OFF	OFF	OFF	OFF	1 COIN	1 CREDIT
ON	OFF	OFF	OFF	ON	OFF	OFF	OFF	1 COIN	2 CREDITS
OFF	ON	OFF	OFF	OFF	ON	OFF	OFF	1 COIN	3 CREDITS
ON	ON	OFF	OFF	ON	ON	OFF	OFF	5 COINS	1 CREDIT
OFF	OFF	ON	OFF	OFF	OFF	ON	OFF	6 COINS	1 CREDIT
ON	OFF	ON	OFF	ON	OFF	ON	OFF	1 COIN	6 CREDITS
OFF	ON	ON	OFF	OFF	ON	ON	OFF	2 COINS	1 CREDIT
ON	ON	ON	OFF	ON	ON	ON	OFF	3 COINS	1 CREDIT
OFF	OFF	OFF	ON	OFF	OFF	OFF	ON	4 COINS	1 CREDIT
ON	OFF	OFF	ON	ON	OFF	OFF	ON	2 COINS	3 CREDITS
OFF	ON	OFF	ON	OFF	ON	OFF	ON	6 COINS	4 CREDITS
ON	ON	OFF	ON	ON	ON	OFF	ON	4 COINS	3 CREDITS
OFF	OFF	ON	ON	OFF	OFF	ON	ON	5 COINS	6 CREDITS
ON	OFF	ON	ON	ON	OFF	ON	ON	4 COINS	5 CREDITS
OFF	ON	ON	ON	OFF	ON	ON	ON	2 COINS	3 CREDITS
ON	ON	ON	ON	ON	ON	ON	ON	NO USE	
COIN SW #1				COIN SW #2					

GAME DIFFICULTY SWITCH SETTING DIP SWITCH B

DIP SWITCH B								GAME OPTION SETTING	
1	2	3	4	5	6	7	8		
OFF	OFF							*CABINET TYPE, MOVING	
ON	OFF							UP RIGHT	
OFF	ON							MINI UP RIGHT	
ON	ON							NO USE	
		OFF						*ADVERTISE SOUND, OFF	
		ON						ON	
			OFF					*EVER OFF.	
				OFF				*INITIAL CREDIT, 2 CREDIT	
				ON				1 CREDIT	
					OFF			*CONTINUE GAME, YES	
					ON			NO	
						OFF	OFF	*GAME DIFFICULTY, NORMAL	
						ON	OFF	EASY	
						OFF	ON	HARD	
						ON	ON	HARDEST	

* When DIP SWITCH B. 5 is set to "ON", also set DIP SWITCH B. 6 to "ON" as a rule.

.... Setting at the time of shipment

25. SPECIFICATIONS FOR THE DIFFERENT TYPES OF MOTORS

There are two types of BANK MOTORS, i.e., (350-5108) and (350-5134).

These two types of motors can be utilized by setting the DRIVE BOARD (839-0213) DIP SWITCHES in a manner as shown. If the setting is incorrect, the motor may not sufficiently function, therefore be sure to follow the setting below:

MOTOR PARTS No.	DRIVE BOARD (839-0213) DIP SWITCHes			
	1	2	3	4
350 - 5133	OFF	OFF	OFF	OFF
350 - 5134	ON	OFF	OFF	OFF

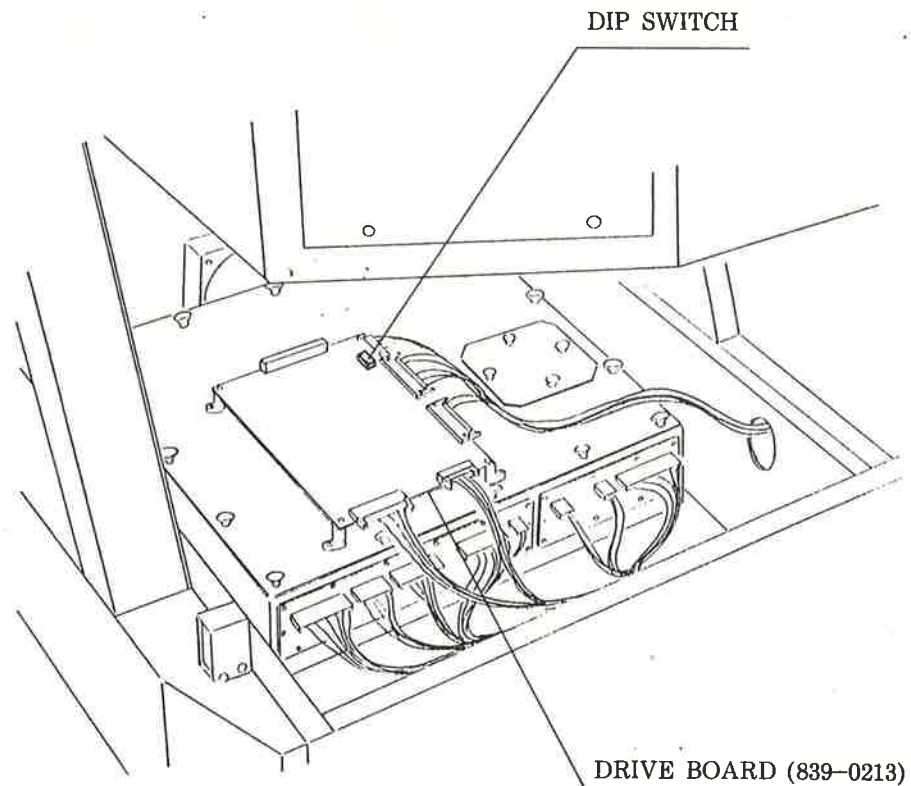

26. EPROM / MASK ROM LOCATIONS

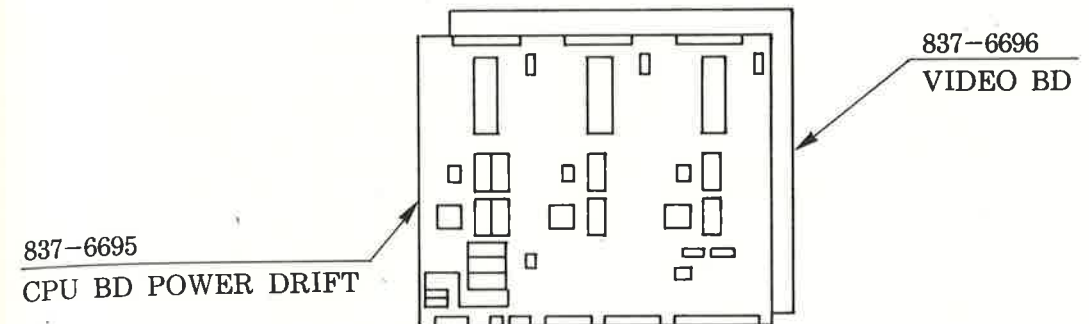

CPU BD POWER DRIFT 837-6695

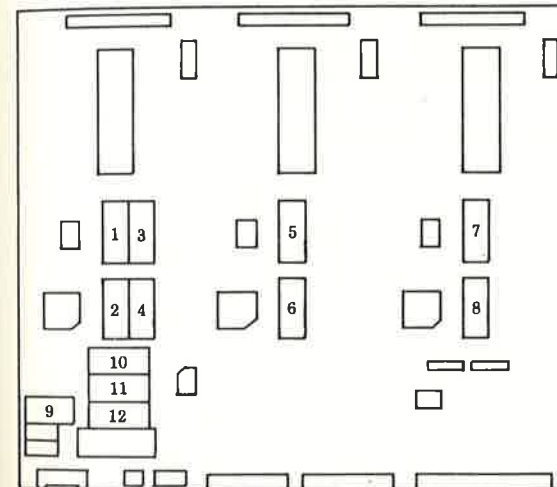

VIDEO BD POWER DRIFT 837-6696

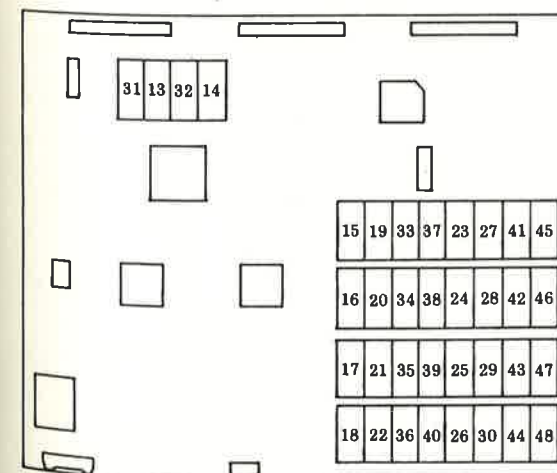

834-6697		GAME BD POWER DRIFT	
837-6695		CPU BD POWER DRIFT	
IC LOCATION	NUMBER	MAIN WORK	
1	IC 24	EPR-11745	PROGRAM
2	IC 25	EPR-11746	
3	IC 26	EPR-11747	
4	IC 27	EPR-11748	
5	IC 53	EPR-11749A	
6	IC 54	EPR-11750A	
7	IC 80	EPR-11751	
8	IC 81	EPR-11752	
9	IC 102	EPR-11753	SOUND PROGRAM
10	IC 107	EPR-11892	(2M EPROM)
11	IC 106	EPR-11893	SOUND DATA
12	IC 105	EPR-11894	
837-6696		VIDEO BD POWER DRIFT	
13	IC 16	EPR-11789	LINE OBJ
14	IC 14	EPR-11791	
15	IC 67	EPR-11757	
16	IC 75	EPR-11758	
17	IC 86	EPR-11759	
18	IC 114	EPR-11760	
19	IC 66	EPR-11761	
20	IC 74	EPR-11762	
21	IC 85	EPR-11763	
22	IC 113	EPR-11764	
23	IC 63	EPR-11773	OBJECT
24	IC 71	EPR-11774	
25	IC 82	EPR-11775	
26	IC 110	EPR-11776	
27	IC 62	EPR-11777	
28	IC 70	EPR-11778	
29	IC 81	EPR-11779	
30	IC 109	EPR-11780	
31	IC 17	EPR-11790	
32	IC 15	EPR-11792	
33	IC 65	EPR-11765	OBJECT
34	IC 73	EPR-11766	
35	IC 84	EPR-11767	
36	IC 112	EPR-11768	
37	IC 64	EPR-11769	
38	IC 72	EPR-11770	
39	IC 83	EPR-11771	
40	IC 111	EPR-11772	
41	IC 61	EPR-11781	
42	IC 69	EPR-11782	
43	IC 80	EPR-11783	
44	IC 108	EPR-11784	
45	IC 60	EPR-11785	
46	IC 68	EPR-11786	
47	IC 79	EPR-11787	
48	IC 107	EPR-11788	

27. PARTS LIST

① TOP ASSY SEGA POWER DRIFT DELUXE (POW-0000) (D-1/2)

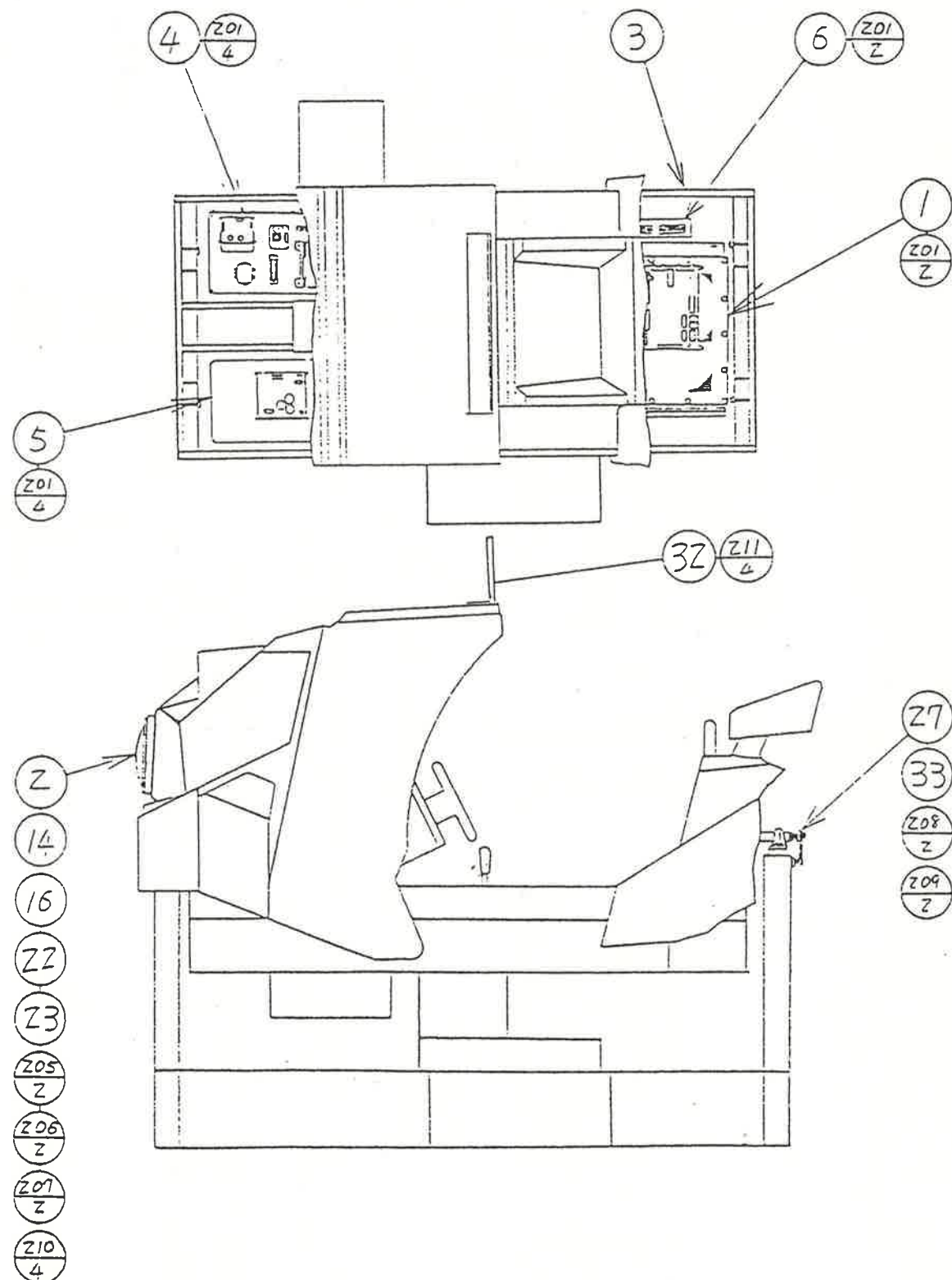

① TOP ASSY SEGA POWER DRIFT DELUXE (POW-0000) (D-2/2)

ITEM NO.	PART NO.	DESCRIPTION
1	POW-0004	ASSY GAME BD UNIT
2	POW-2000	ASSY MONOCOQUE
3	POW-3000	ASSY BASE
4	POW-4000	ASSY PWR SPLY
5	POW-4100	ASSY DRIVE SPLY
6	POW-4200	ASSY TERMINAL BASE
7	SGB-1035X	KEY BAG
8	SGM-2675	POLYETHYLENE BAG 240×370
9	SGM-3743	POLYETHYLENE COVER
10	984	SCHEMATIC DIAGRAM SEGA POWER DRIFT
11	420-5891-04	OWNERS MANUAL POWER DRIFT DELUXE ENG
15	220-5254	KEY MASTER FOR 220-5253
16	117-5039	PLATE ELEC SPEC
17	420-5881	DSPL MANUAL 26' 200-5112 ENG
	420-5882	DSPL MANUAL 26' 200-5125 ENG
18	421-6594	STICKER SERIAL NO. INFO
19	421-6709	STICKER SERVICE INSTR ENG.
20	421-6671	STICKER DANGER HIGH VOLTAGE
21	421-7309	ADJUST INSTR SHEET POWER DRIFT
22	421-5800-81	ORIGINAL SEAL POWER DRIFT
23	422-0254-01	PLAY INSTR SH POWER DRIFT
24	421-6241	STICKER DAINGER ENG.
25	421-7010-01	STICKER CAUTION ENG.
26	421-7012-01	INSTR SHEET FOR BOLT ENG.
27	601-6005	ADJUST GEAR
29	540-0017	DRIVER FOR TAMP PRF SCR M5
	540-0007-01	WRENCH FOR TAMP PRF SCR DUAL TYPE M5
30	540-0018	DRIVER FOR TAMP PRF SCR M4
	540-0006-01	WRENCH FOR TAMP PRF SCR DUAL TYPE M4
31	540-0015-01	WRENCH FOR TAMP PRF SCR DUAL TYPE M6
32	POW-0012-01	DISPLAY PLATE POWER DRIFT ENG.
33	POW-0014	ADJUST RING
201	000-0420-F	M SCR PH W/F M4×20
205	050-0016	HEX NUT M16
206	069-0042	FLT WSHR M16
207	069-0060	SPR WSHR M16
208	000-0408-FS	M SCR PH W/FS M4×8
209	028-0021	SET SCR PH SPECIAL M4×16
210	047-0001	RIVET OPEN TYPE (TAP/D(41)) BS 3.2×4.4
211	005-3113-F	W SCR RH W/F 3.1×13

② ASSY GAME BD UNIT (POW-0004)

(D-1/2)

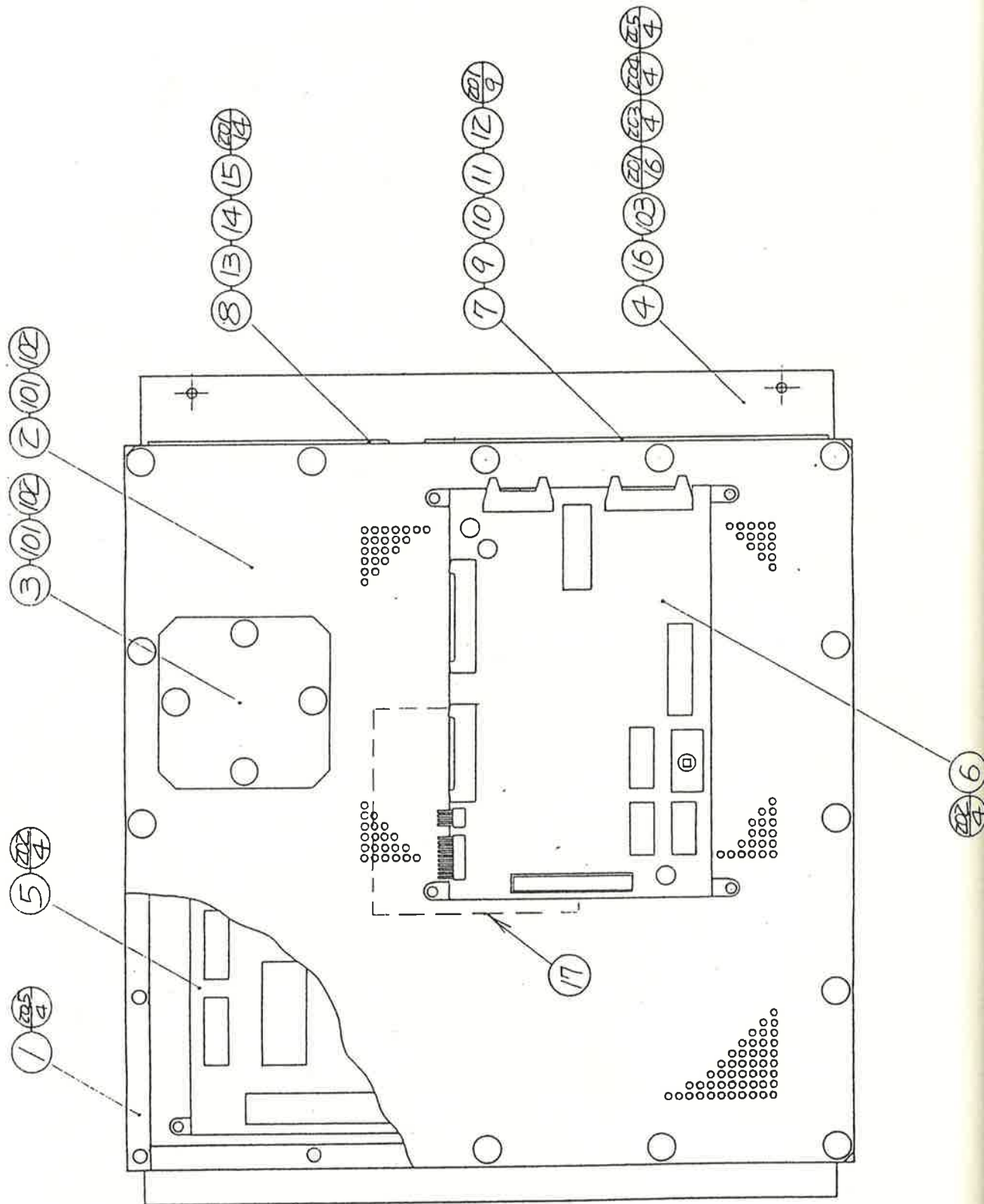

② ASSY GAME BD UNIT (POW-0004)

(D-2/2)

ITEM NO.	PART NO.	DESCRIPTION
1	POW-0005	SHIELD CASE
2	POW-0006	SHIELD CASE LID
3	POW-0007	DIP SWITCH LID
4	POW-0008	SHIELD CASE TRAY
5	834-6697-03	GAME BD POWER DRIFT EXPORT
6	839-0213	DRIVE BD POWER DRIFT
7	839-0211	FILTER BD A POWER DRIFT
8	839-0212	FILTER BD B POWER DRIFT
9	600-5740-21	CONN JST 20P & AMP 10P×2
10	600-5740-22	CONN JST 15P, 18P & AMP 50P
11	600-5740-23	CONN JST 12P & AMP 20P
12	600-5740-24	CONN JST 4P, 6P
13	600-5740-25	CONN JST 4P, 5P
14	600-5740-26	CONN JST 25P & FLAT 26P
15	600-5740-27	CONN JST 6P×2
16	POW-0013	RUBBER BRACKET
17	POW-0015	PAD
101	280-5079	NYLATCH/GROMMET
102	280-5080	NYLATCH PLUNGER
103	601-6195	RUBBER DUMPER
201	010-0308-F	S-TITE SCR PH M3×10
202	029-0023	S-TITE SCR FH M3×8
203	000-0412-FS	M SCR PH W/FS M4×12
204	000-0425	M SCR PH M4×25
205	051-0004	FLG NUT M4

③ ASSY MONOCOQUE (POW-2000)

(D-1/3)

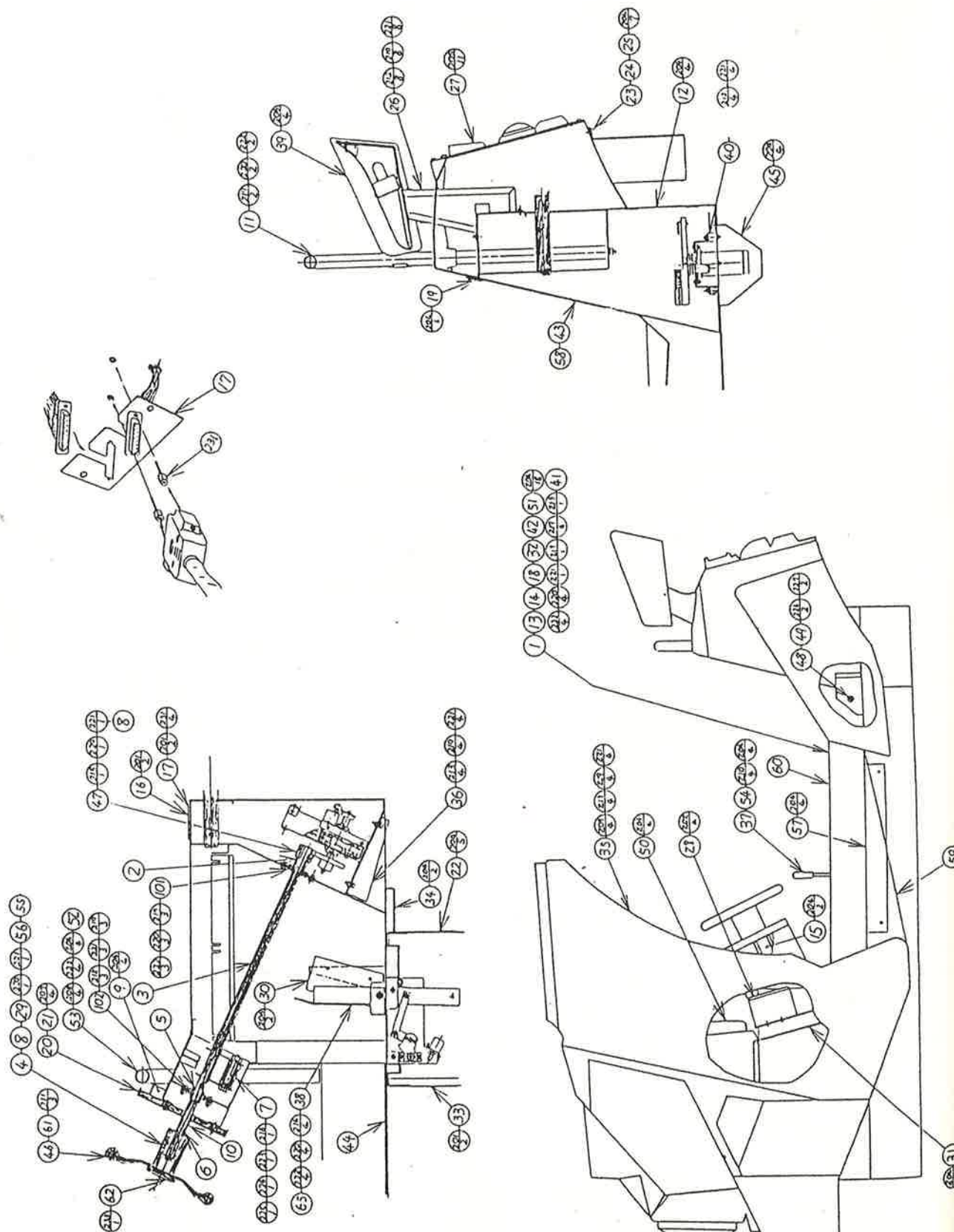

③ ASSY MONOCOQUE (POW-2000)

(D-2/3)

ITEM NO.	PART NO.	DESCRIPTION
1	POW-2001	MONOCOQUE
2	POW-2002	GEAR SPACER
3	POW-2003X	STEERING SHAFT
4	POW-2004	STEERING BOSS
5	POW-2005	STEERING SPACER
6	POW-2006	BOSS SPACER 20
7	POW-2007	STP. RUBBER
8	POW-2008	KEY
9	POW-2009	METER BACK COVER
10	POW-2010	BOSS SPACER 60
11	POW-2017	REAR ROLL BAR
12	POW-2018X	REAR LID
13	POW-2019	FRONT LID
14	POW-2020	RIGHT LID
15	POW-2021	WIRE COVER A
16	POW-2022	CONNECTOR BRKT A
17	POW-2023	CONNECTOR BRKT B
18	POW-2024	CONNECTOR BRKT C
19	POW-2025	EDGE BRKT L
20	POW-2027	ASSY DASH PANEL
21	POW-2031	DASH PANEL SPACER
22	POW-2032	PEDAL COVER A
23	POW-2033	GUARD SHEET
24	POW-2034	PROTECTOR BRACKET A
25	POW-2035	PROTECTOR BRACKET B
26	POW-2011	WING BASE
27	POW-2012	ASSY BODY REAR
28	POW-2015	ASSY SP BOX
29	POW-2036	EXTENDER 20
30	POW-2037	FOOT REST EXTENDER
31	POW-2038	SP. WIRE COVER
32	POW-2039	LEFT LID
33	POW-2040	PEDAL COVER B
34	POW-2041	WIRE COVER C
35	POW-1000	ASSY CABINET
36	POW-2100	ASSY HANDLING
37	POW-2200	ASSY TRANSMISSION
38	POW-2300	ASSY ACCEL & BRAKE
39	POW-2400	ASSY WING
40	POW-2500	ASSY VIBRATOR
41	POW-1100	ASSY COINCHUTE TOWER
42	POW-0009	WIRE COVER B
43	POW-2042X	SEAT COVER
44	POW-2043	FLOOR MAT
45	POW-2044	VIBRATOR COVER
46	KR-1121X	STEELING HANDLE ϕ 270
47	KR-1127	GEAR B
48	RH-1104	SEAT BELT
49	RH-1118	SHOULDER SCREW
50	POW-0001	ASSY CLR DSPL 26 TYPE
51	POW-2045	BOTTOM PLATE
52	POW-2046	ASSY SW PLATE
53	POW-2048	FRONT ROLL BAR
54	POW-2049	DESIGN SHIFT PLATE
55	POW-2050	MOUNT SCREW L

③ ASSY MONOCOQUE (POW-2000)

(D-3/3)

ITEM NO.	PART NO.	DESCRIPTION
56	POW-2051	MOUNT SCREW S
57	POW-2052	STEP GUARD
58	POW-2053	SEAT CUSHION
59	POW-2054	STICKER MONOCOQUE L
60	POW-2055	STICKER MONOCOQUE R
61	POW-2056	COUPLING SPACER
62	HL-2010	EMBLEM PLATE
63	POW-2057	METER BACK PANEL B
64	KR-1122	KEY A
65	POW-2058	BLIND PLATE
	090-0003	DOUBLU FACE TAPE CLOTH 20mm×15M/ROLL
101	100-5030	BEARING ϕ 20
102	100-5080	BEARING ϕ 17
104	509-5244	SW MICRO TYPE
201	000-0410-FS	M SCR PH W/SF M4×10
202	000-0510-FS	M SCR PH W/FS M5×10
203	000-0520-FS	M SCR PH W/FS M5×20
204	008-0410	TMP PRF SCR TH M4×10
205	008-0416	TMP PRF SCR TH M4×16
206	008-0510	TMP PRF SCR TH M5×10
207	029-0192	TMP PRF SCR TH CROME M5×20
208	029-0078	TMP PRF SCR BH M6×16
209	029-0079	TMP PRF SCR TH M6×35
210	029-0202	THIN HEAD SCR HEX SKT M5×12
211	029-0203	HEX SKT H CAP SCR BLK M6×40
212	030-0620	HEX BLT M6×20
213	030-0630	HEX BLT M6×30
214	030-0820	HEX BLT M8×20
215	030-0610	HEX BLT M6×10
216	039-0054	HEX BLT M12×90
217	050-0008	HEX NUT M8
218	050-0006	HEX NUT M6
219	060-0006	FLT WSHR M6
220	060-0008	FLT WSHR M8
221	061-0006	SPR WSHR M6
222	061-0008	SPR WSHR M8
223	059-0017	HEX NUT M12
224	061-0012	SPR WSHR M12
225	069-0020	FLT WSHR M12
226	050-0010	HEX NUT M10
27	061-0010	SPR WSHR M10
228	069-0028	FLT WSHR BLK 6.2-15×1.2
229	069-0083	FLT WSHR 6.4-24×1.6
231	211-5304	CONN SCR
232	008-0425	TMP PRF SCR TH M4×25
233	008-0440	TMP PRF SCR TH M4×40

④ ASSY BODY REAR (POW-2012)

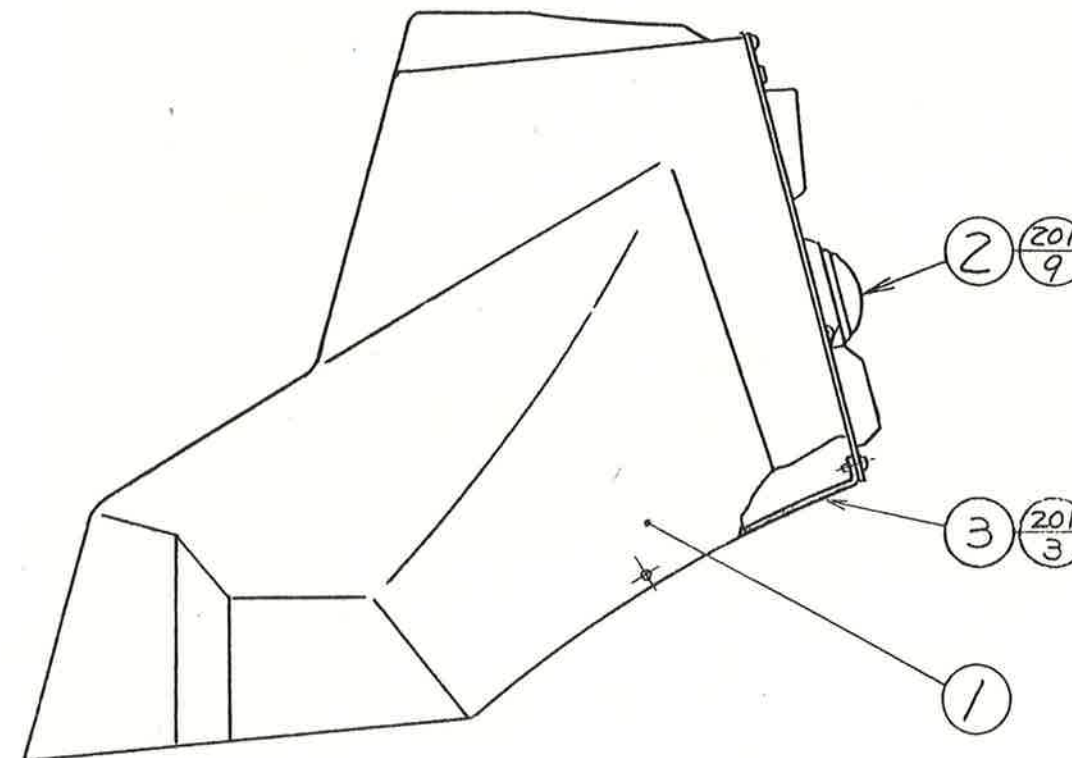

ITEM NO.	PART NO.	DESCRIPTION
1	POW-2013	BODY REAR W/O MASK
2	POW-2014	MASK REAR
3	POW-2026	REAR PLATE
201	008-0412	TMP PRF SCR TH M4×12

⑤ ASSY DASH PANEL (POW-2027)

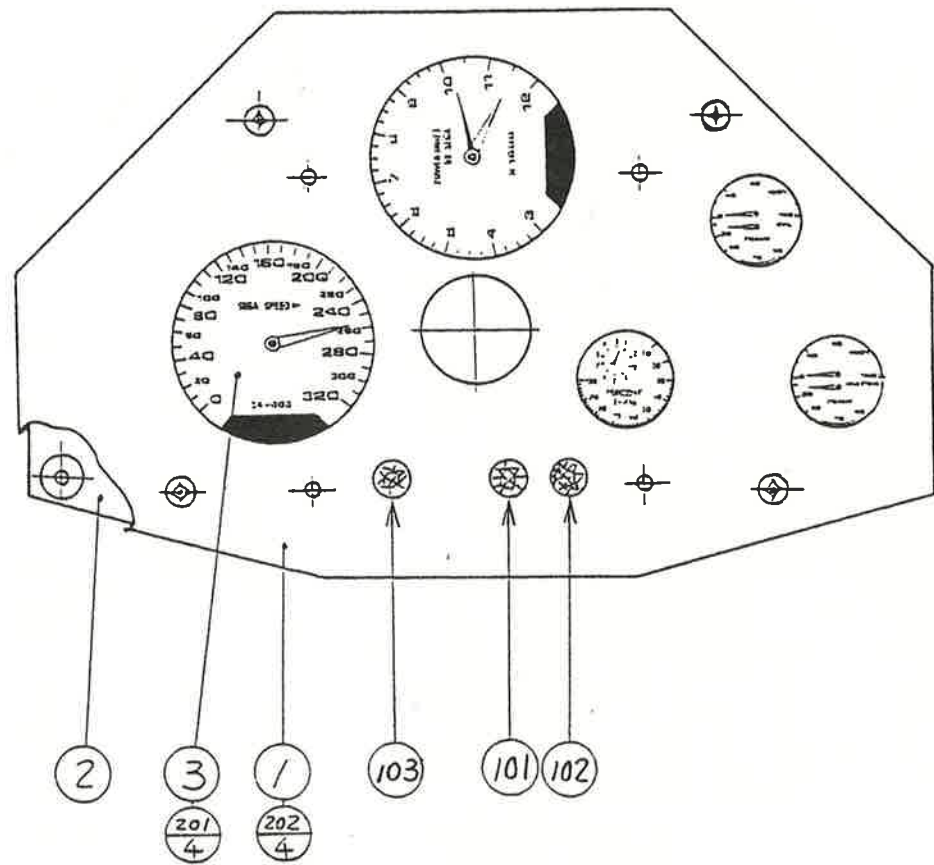

ITEM NO.	PART NO.	DESCRIPTION
1	POW-2028	DASH PANEL
2	POW-2029	BACK PANEL
3	POW-2030	DESIGN PANEL
101	390-5240-03	NEON
102	390-5240-02	NEON
103	390-5240-01	NEON
201	000-0414-F	M SCR PH W/F M4×14
202	029-0152	TMP PRF SCR TH CROME M5×12

⑥ ASSY SP BOX (POW-2015)

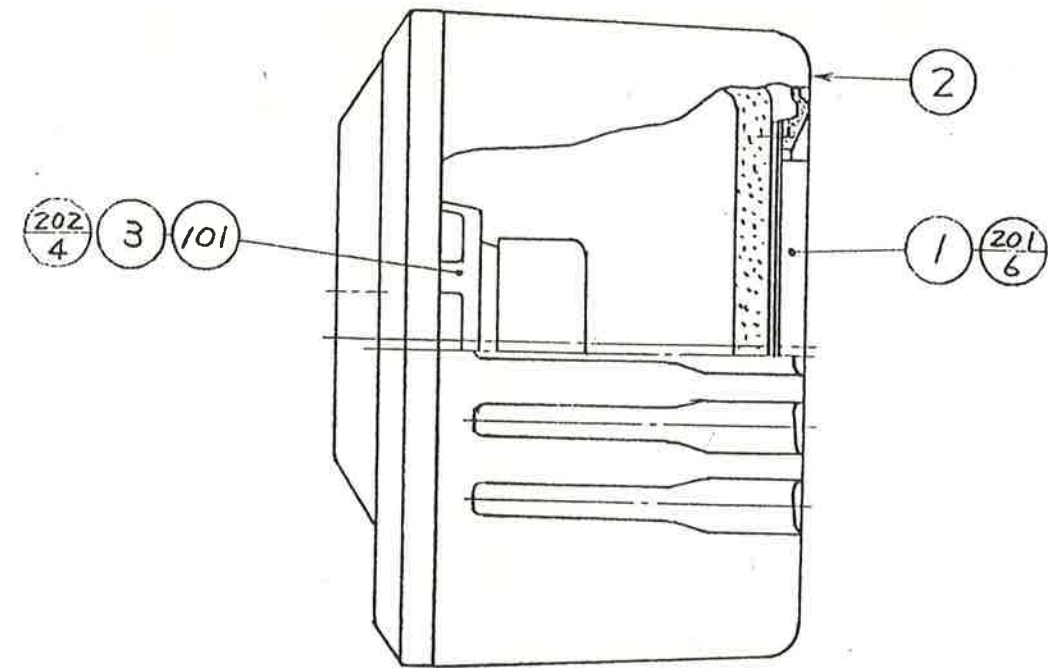

ITEM NO.	PART NO.	DESCRIPTION
1	POW-2016	REAR PLATE
2	253-5313	BOX SP
3	280-5127	SPACER FOR SP
101	130-5029	SPEAKER 10cm 8 OHM 15W W/SHIELD
201	000-0310-F	M SCR PH W/F M3×10
202	012-0408	TAP SCR PH M4×8

⑦ ASSY CABINET (POW-1000)

(D-1/2)

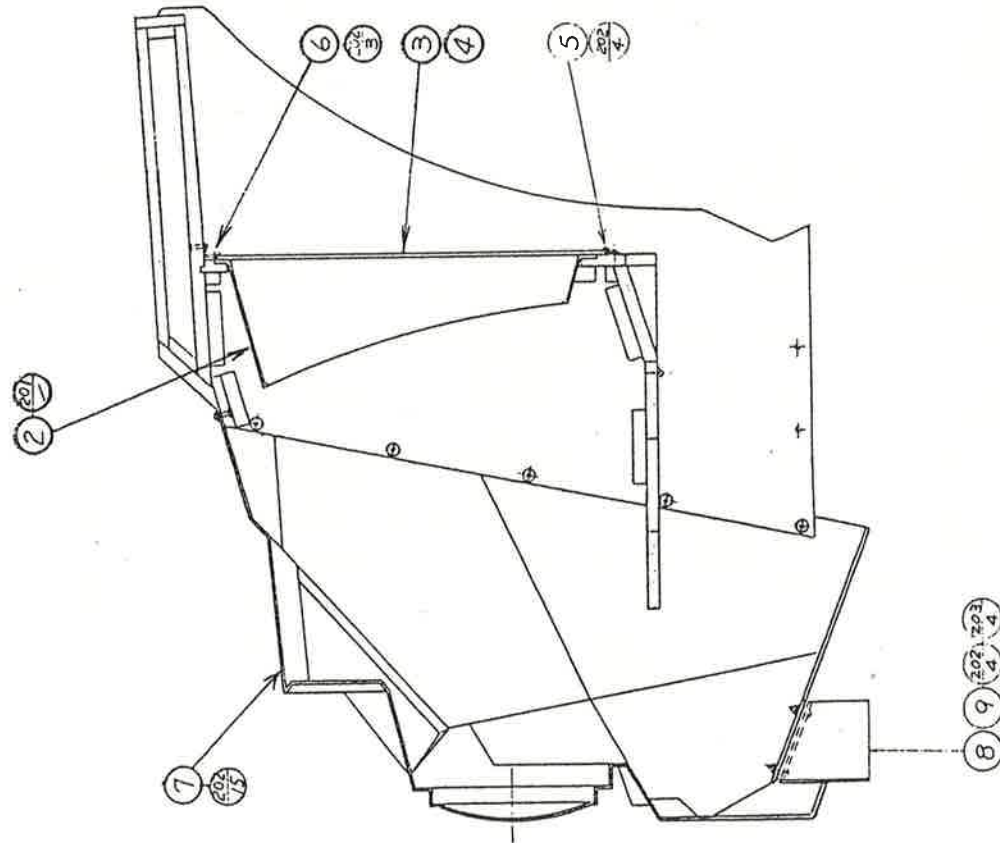
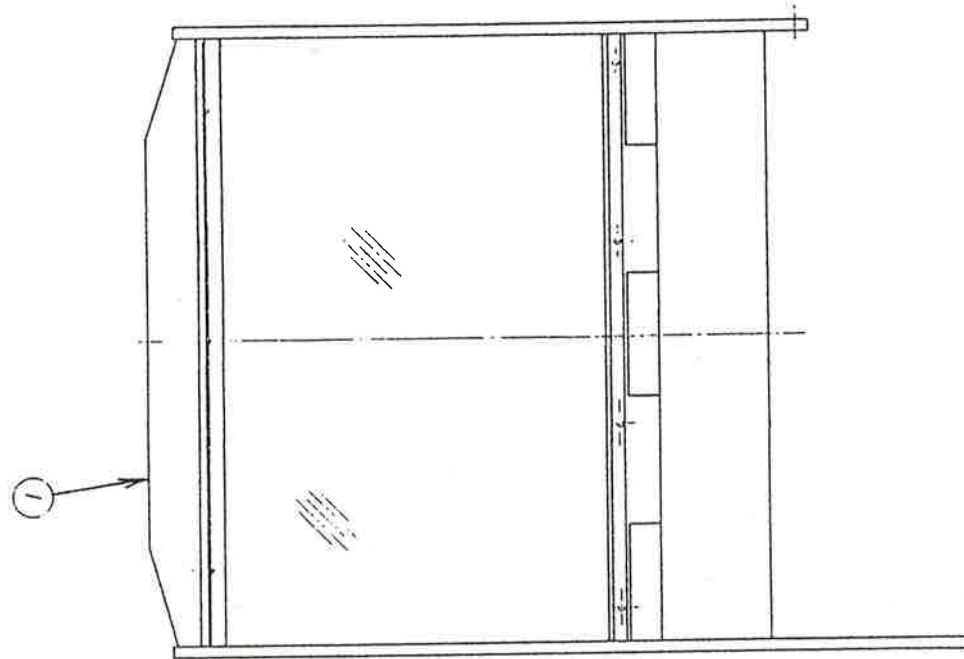

⑦ ASSY CABINET (POW-1000)

(D-2/2)

ITEM NO.	PART NO.	DESCRIPTION
1	POW-1001	ASSY SUB CABINET
2	POW-1003	TV MASK 26 TYPE
3	POW-1004	WINDOW GLASS
4	POW-1005	RUBBER PACKING A
5	POW-1007	SUPPORTER LOWER
6	POW-1008	SUPPORTER UPPER
7	POW-1010	ASSY BONNET
8	POW-1013	GUARD SHEET
9	POW-1014	SUPPORTER
201	090-0003	DOUBLE FACE TAP CLOTH 20mm×15M/ROLL
202	008-0416	TMP PRF SCR TH M4×16
203	051-0004	FLG NUT M4

⑧ ASSY HANDLING (POW-2100)

(D-1/2)

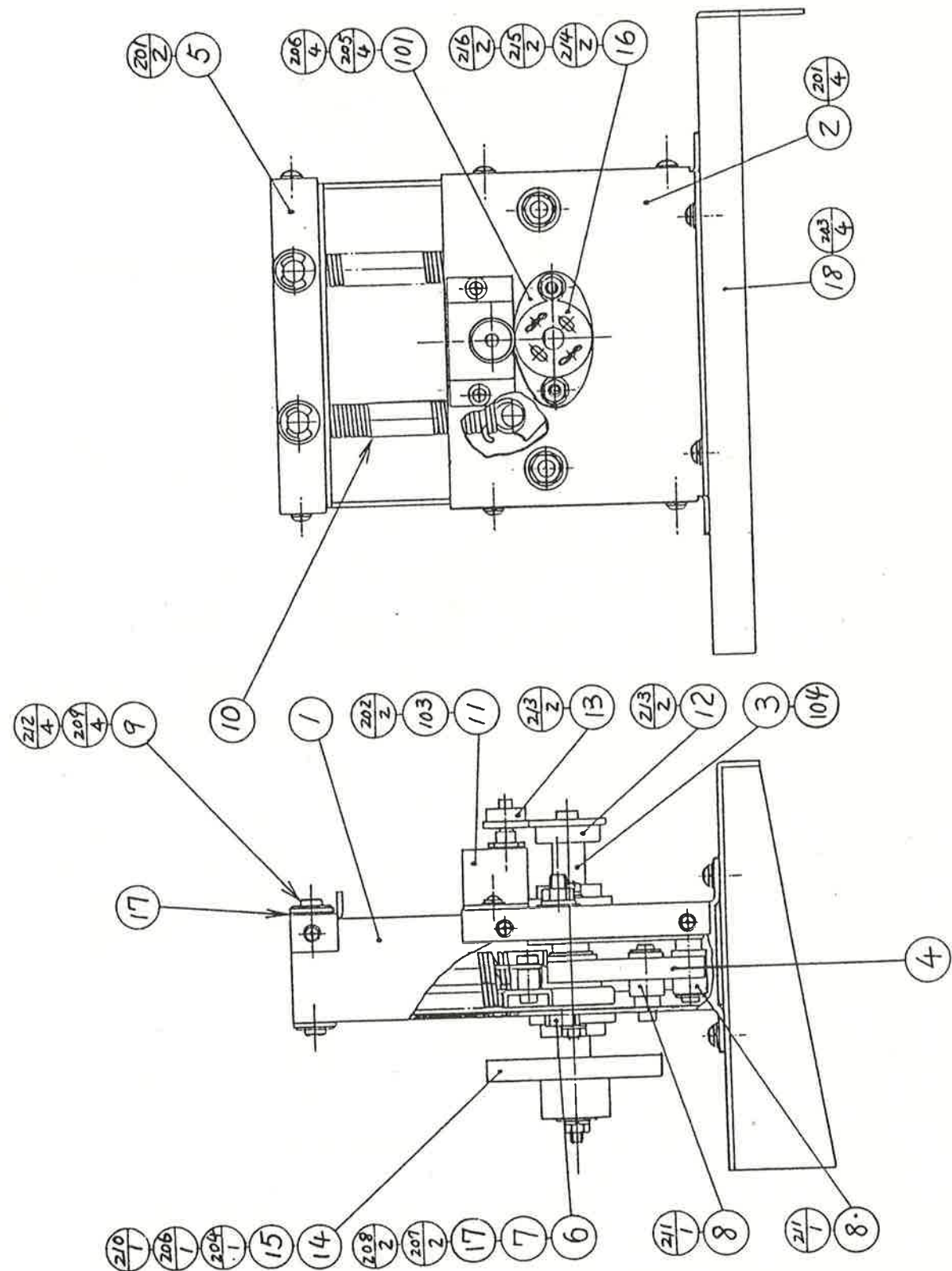

⑧ ASSY HANDLING (POW-2100)

(D-2/2)

ITEM NO.	PART NO.	DESCRIPTION
1	POW-2101	HANDLING BRKT A
2	POW-2102	HANDLING BRKT B
3	POW-2103	SWING ARM SHAFT
4	POW-2104	CENTERING BRKT
5	POW-2105	S HOLDER BRKT
6	POW-2106	STOPPER SCREW
7	POW-2107	STOPPER RUBBER
8	POW-2108	ROLLER
9	POW-2109	S HOLD SHAFT
10	POW-2110	EXT SPRING
11	POW-2111	VR BRKT
12	POW-2112	ADJUST RING
13	KR-1129	GEAR D
14	POW-2113	KEY
15	KR-1126	GEAR A
16	601-6172	GEAR 48
17	POW-2114	RUBBER
18	POW-2115	HANDLING BASE BRKT
101	100-5079	BEARING ϕ 15
103	220-5130	VOL CONT B-5K OHM
104	280-5130	THRUST WSHR ϕ 15.3
201	000-0510-FS	M SCR W/FS M5 \times 10
202	000-0410-FS	M SCR PH W/FS M4 \times 10
203	000-0514-FS	M SCR PH W/FS M5 \times 14
204	061-0006	SPR WSHR M6
205	060-0006	FLT WSHR M6
206	054-0006	U NUT M6
207	060-0008	FLT WSHR M8
208	050-0008	HEX NUT M8
209	060-0010	FLT WSHR M10
210	069-0002	FLT WSHR 6.5-19 \times 1.2
211	065-0007	E RING 7mm
212	065-0009	E RING 9mm
213	028-0014	SET SCR HEX SKT CP UNBR M4 \times 4
214	032-0410	WNG BLT M4 \times 10
215	060-0004	FLT WSHR M4
216	061-0004	SPR WSHR M4

⑨ ASSY TRANSMISSION (POW-2200)

(D-1/2)

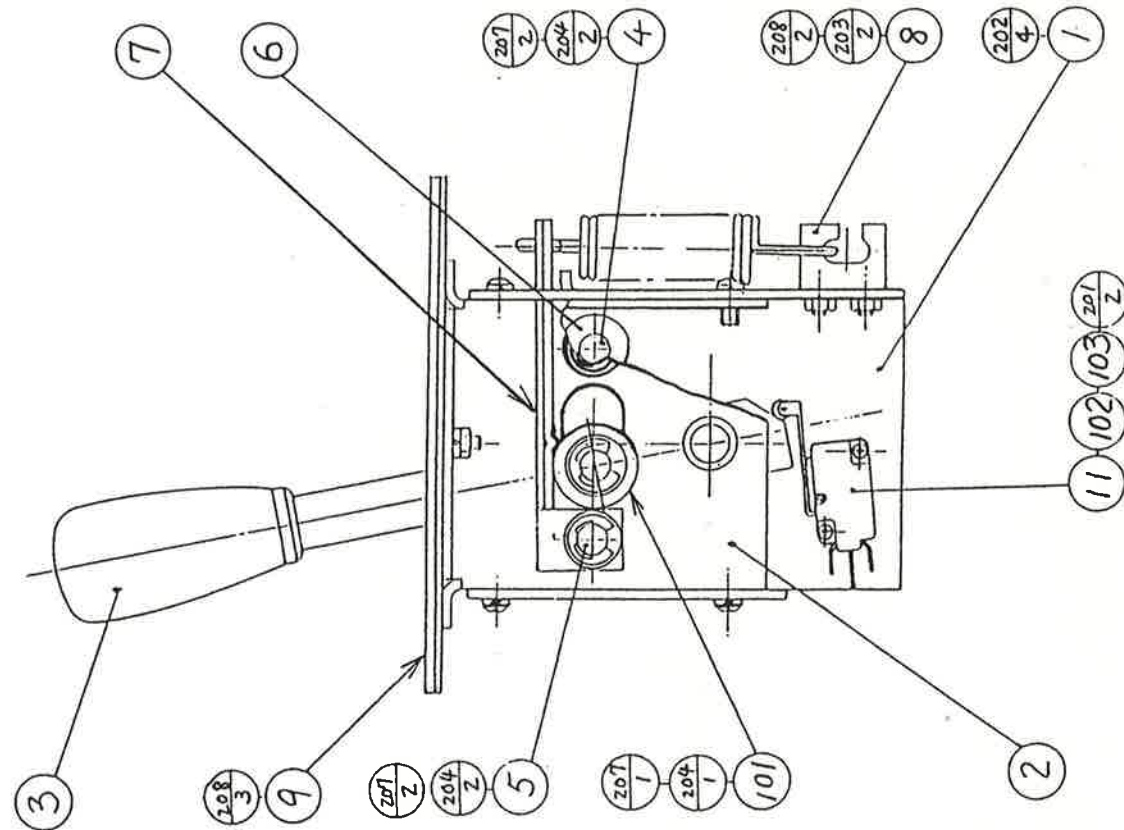
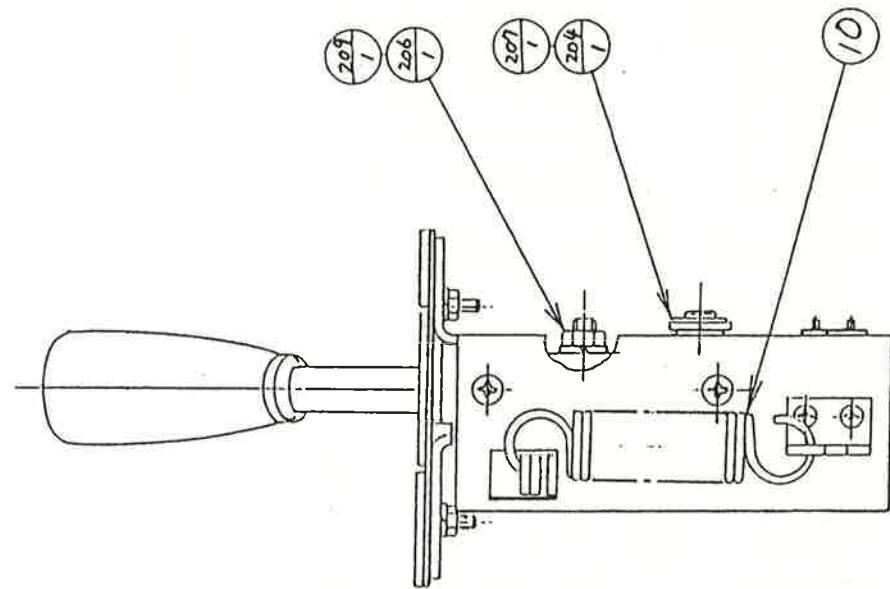

⑨ ASSY TRANSMISSION (POW-2200)

(D-2/2)

ITEM NO.	PART NO.	DESCRIPTION
1	POW-2201	TRANSMISSION CASE A
2	POW-2202	TRANSMISSION CASE B
3	POW-2213	SUB ASSY SHIFT LEVER
4	POW-2204	STOPPER SHAFT A
5	POW-2205	STOPPER SHAFT B
6	POW-2206	STOPPER RUBBER
7	POW-2207	CAM,
8	POW-2208	HOOK
9	POW-2209	SLIDE BASE BRKT
10	POW-2210	EXT SPRING
11	310-0012	PAPER INSULATOR
101	100-5018	BALL BEARING $\phi 8$
102	509-5088	SW MICRO TYPE
103	117-0141	LOCK PLATE
201	000-0320-FS	M SCR PH W/FS M3x20
202	000-0510-S	M SCR W/S M5x10
203	000-0416-S	M SCR W/S M4x16
204	065-0007	E RING 7mm
206	061-0006	SPR WSHR M6
207	060-0008	FLT WSHR M8
208	054-0004	U NUT M4
209	054-0006	U NUT M6

⑩ ASSY ACCEL & BRAKE (POW-2300)

(D-1/2)

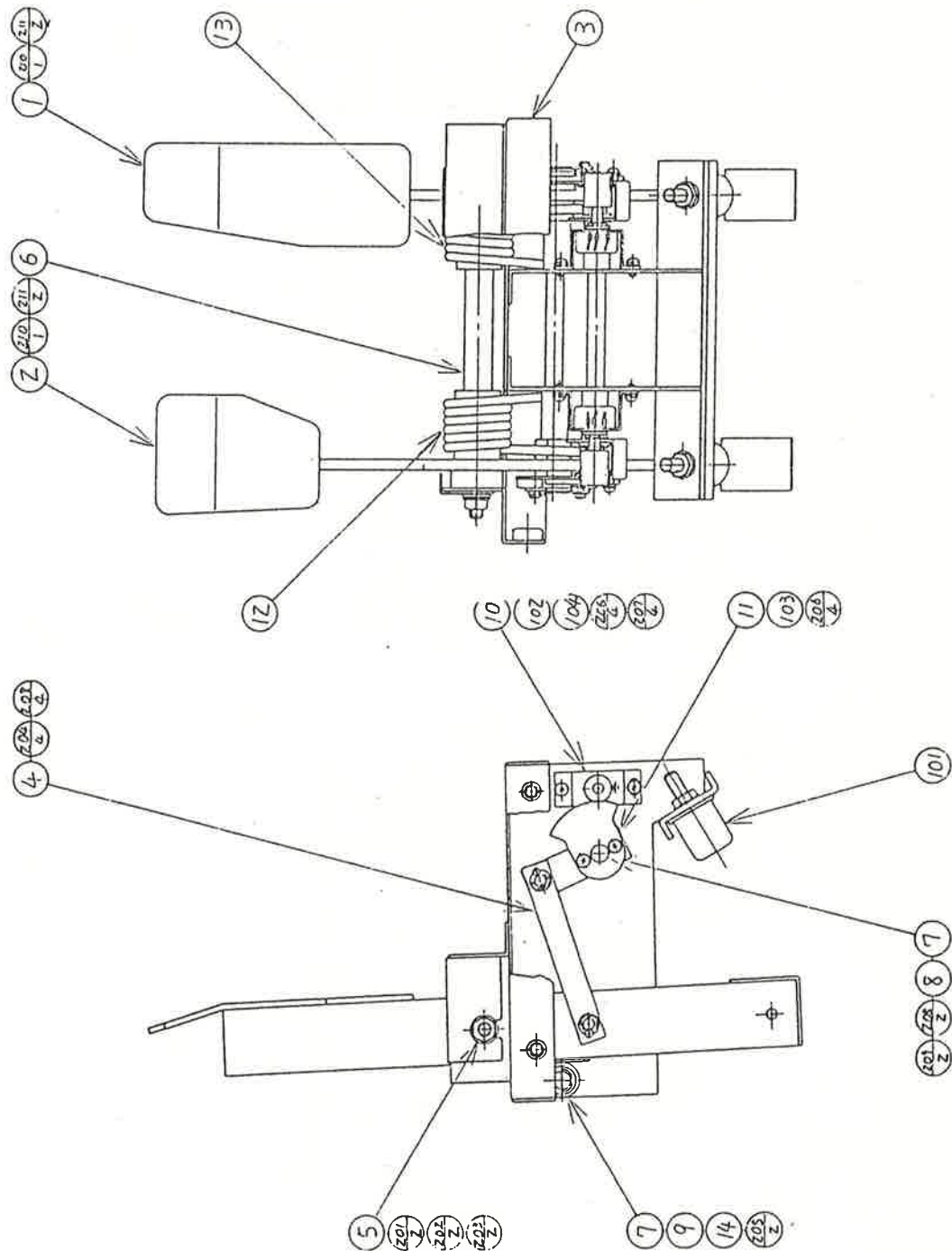

⑩ ASSY ACCEL & BRAKE (POW-2300)

(D-2/2)

ITEM NO.	PART NO.	DESCRIPTION
1	POW-2301X	ACCELERATOR PEDAL
2	POW-2302X	BRAKE PEDAL
3	POW-2303	PEDAL BRKT
4	POW-2304	LINK
5	POW-2305	SHAFT BRAKE ACCEL
6	POW-2306	COLLAR A
7	POW-2307	COLLAR B
8	POW-2308	SHAFT GEAR
9	POW-2309	SHAFT STOPPER
10	POW-2310	VR BRKT
11	POW-2311	GEAR HOLDER
12	POW-2312	TORSION SPRING A
13	POW-2313	TORSION SPRING B
14	POW-2314	BUMPER
15	POW-2315	PEDAL COVER
101	601-6167	STOPPER KI-30
102	601-5943	GEAR 20 ϕ 15
103	601-6005	ADJUST GEAR
104	220-5130	VOL CONT B-5K OHM
201	050-0008	HEX NUT M8
202	061-0008	SPR WSHR M8
203	060-0008	FLT WSHR M8
204	045-0005	COT PIN 2x15
205	065-0008	E RING 8mm
206	000-0408-FS	M SCR W/FS M4x8
207	028-0001	SET SCR HEX SKT CP UNBR M3x4
208	060-0006	FLT WSHR M6
209	060-0010	FLT WSHR M10
210	000-0510-S	M SCR PH W/S M5x10
211	069-0001	FLT WSHR 5.5-20x1.6

⑪ ASSY WING (POW-2400)

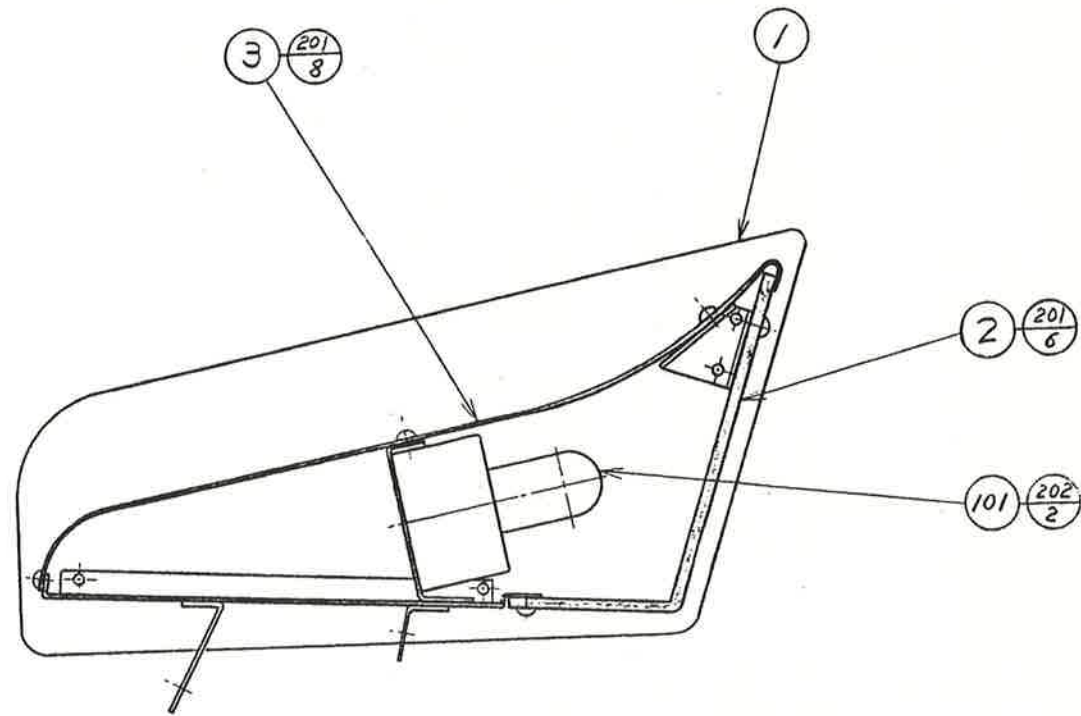

ITEM NO.	PART NO.	DESCRIPTION
1	POW-2401	ASSY WING & BASE
2	POW-2402	DESIGN PLATE REAR
3	POW-2403	WING HORIZONTAL
101	390-5108-02	ASSY FL LIGHT 15W 50HZ MELLOW LOOK
201	008-0408	TMP PRF SCR TH M4x8
202	010-0406-F	S-TITE SCR PH W/F M4x6

⑫ ASSY VIBRATOR (POW-2500)

(D-1/2)

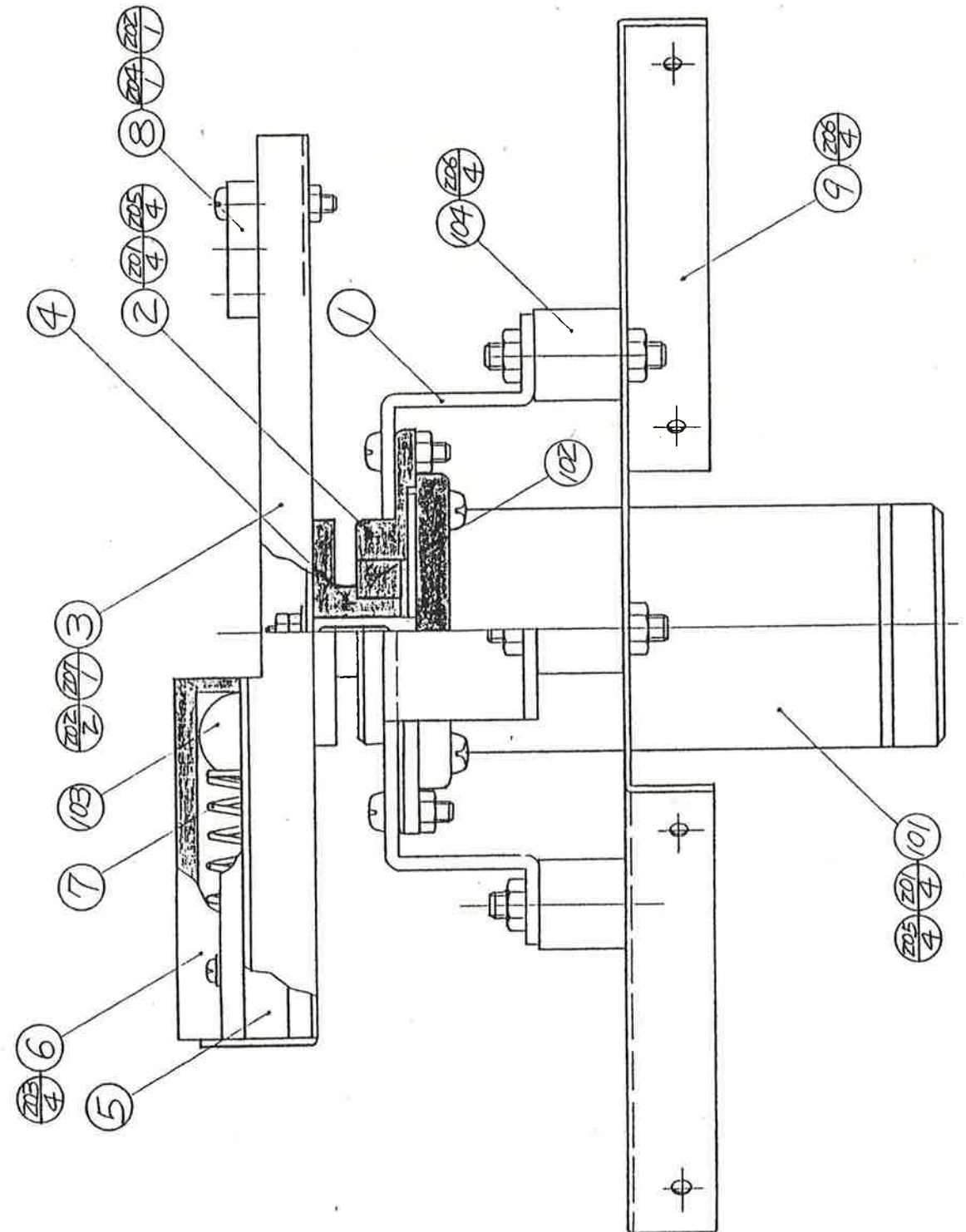

⑫ ASSY VIBRATOR (POW-2500)

(D-2/2)

ITEM NO.	PART NO.	DESCRIPTION
1	POW-2501	MOTOR BASE
2	POW-2502	BOSS
3	POW-2503	BALANCE BLADE
4	POW-2504	BLADE HOLDER
5	POW-2505	SLIDER LOWER
6	POW-2506	SLIDER UPPER
7	POW-2507	COMP SPRING
8	POW-2508	BALANCE WEIGHT
9	POW-2509	MOUNT PLATE
101	350-5140	MOTOR DC 70V W/ENCODER
102	100-5070	BEERING ϕ 15
103	101-5012	STEEL BALL ϕ 20
104	601-6174	RUBBER DUMPER
201	000-0520	M SCR PH M5 \times 20
202	050-0004	HEX NUT M4
203	000-0310-FS	M SCR PH W/FS M3 \times 10
204	000-0425-FS	M SCR PH W/FS M4 \times 25
205	054-0005	U NUT M5
206	054-0006	U NUT M6
207	060-0004	FLT WSHR M4

⑬ ASSY COIN CHUTE TOWER (POW-1100)

(D-1/2)

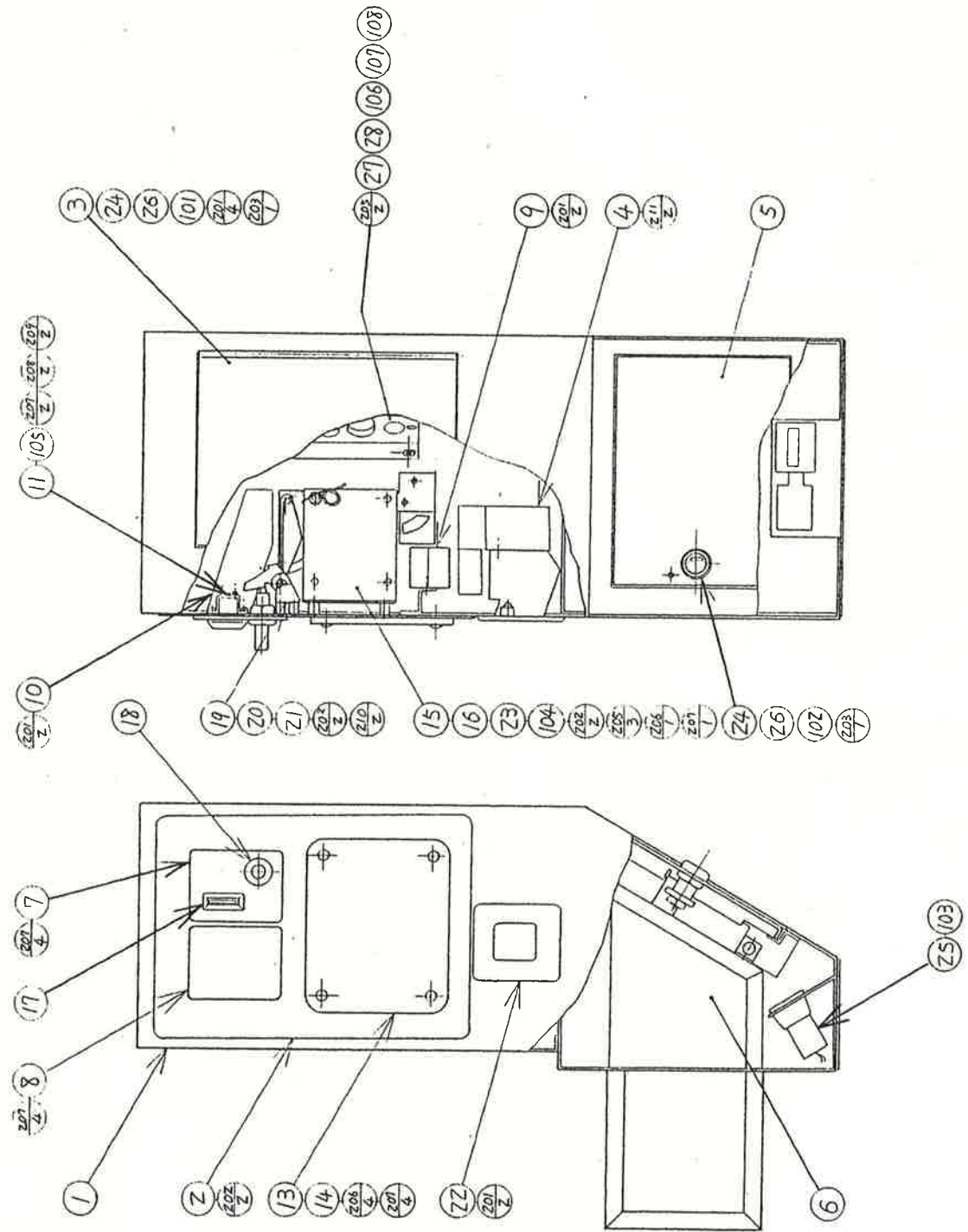

13

ASSY COIN CHUTE TOWER (POW-1100)

(D-2/2)

ITEM NO.	PART NO.	DESCRIPTION
1	POW-1101	COIN CHUTE TOWER
2	POW-1102	COIN CHUTE PANEL
3	POW-1103	COIN CHUTE DOOR
4	POW-1104	LOWER COIN CHUTE
5	POW-1105	DOOR CASH BOX
6	POW-1106	CASH BOX
7	POW-1107	COIN ENTRY PLATE
8	POW-1108	BLIND PLATE
9	POW-1109	REJECT COIN CHUTE
10	YZ-1205	COIN ENTRY CHUTE
11	YZ-1212	BLOCKER BRKT
13	POW-1110	DENOMINATION PLATE
14	MX-1103	DENOMINATION SHEET
15	HN-3002	COIN CHUTE BRKT BASE
16	220-5086	COIN CHUTE BRKT
17	220-5167	COIN ENTRY
18	240-0097	ASSY REJECT BUTTON
19	112-0002	LEVER REJECT
20	105-0015	BRKT REJECT LEVER
21	123-0035	SHAFT
22	220-5205	REJECT CUP & FLAP DOOR ASSY
23	109-0045	HOLDER KEY TURBO UPR
24	DP-1167	TNG LKG
25	421-6591	STICKER COIN METER
26	421-6682	STICKER SERVICE INSTRUCTION
27	KR-1405	SW BRACKET
28	421-6511	STICKER SW
29	MX-1103-04	DENOMINATION SHEET 1 GAME
101	220-5253	MAGNETIC LOCK MASTER W/O KEY
102	220-5046-91	MAGNETIC LOCK W/KEY
103	220-5064	MAG CNTR 6DIG DC 5V
104	220-5208	COIN CHUTE REJR
105	124-5020	SOL 2WAY LACH DC 24V
106	509-5028	SW PB 1M
107	601-0042	KNOB 22mm
108	220-5179	VOL CONT B-5K OHM
201	000-0306-SF	M SCR PH W/SF M3x6
202	000-0408-SF	M SCR PH W/SF M4x8
203	000-0430	M SCR PH M4x30
204	010-0406-F	S-TITE SCR PH W/F M4x6
205	010-0410-F	S-TITE SCR PH W/F M4x10
206	031-0410-B	CRG BLT BLK M4x10
207	051-0004	FLG NUT M4
208	029-0188	M SCR PH M2.6x4
209	069-0078	SPR WSHR M2.6
210	069-0057	E WSHR 3.2mm
211	029-0046	TAP SCR PH W/F M3x8

14

ASSY CLR DSPL 26 TYPE (POW-0001)

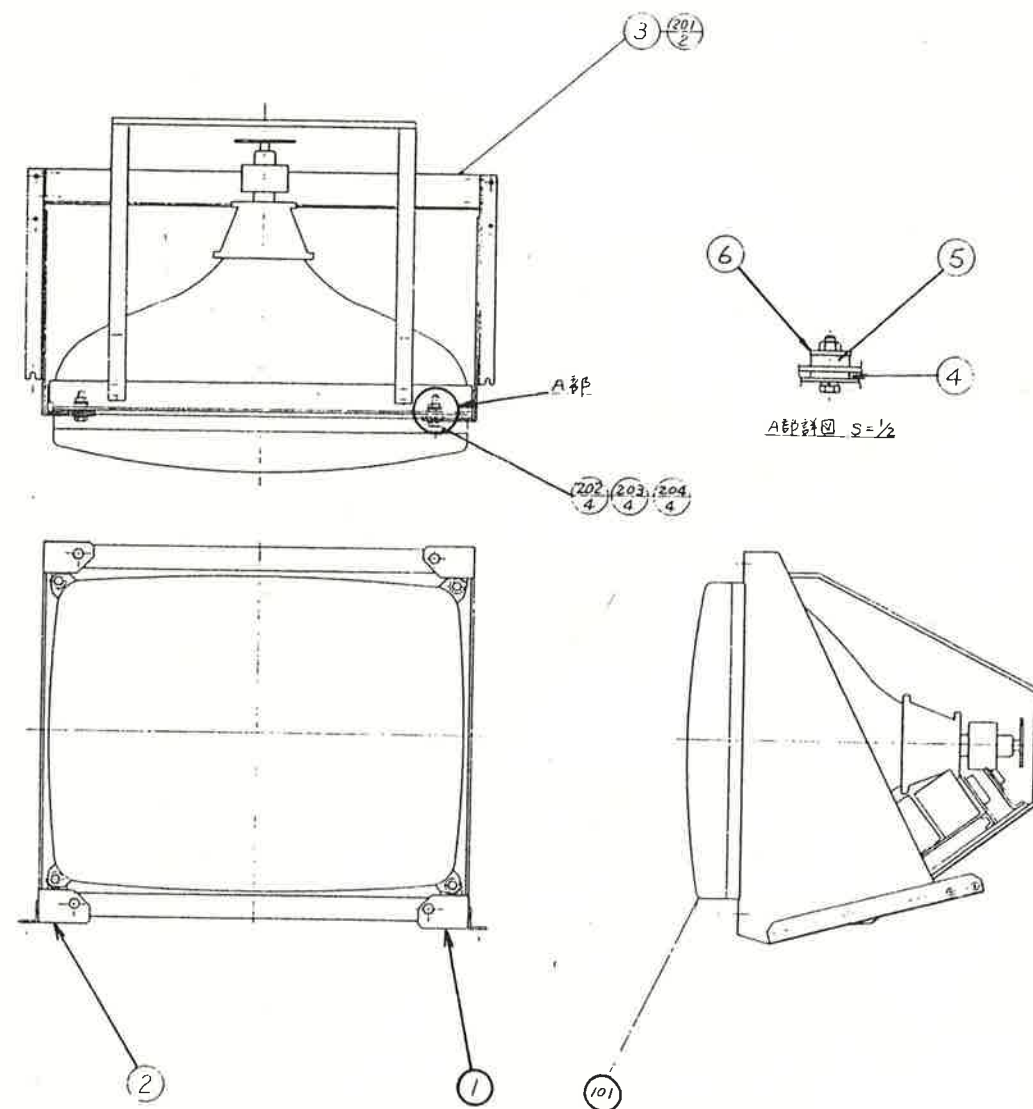

ITEM NO.	PART NO.	DESCRIPTION
1	POW-0002	BRACKET MONITOR 26' LEFT
2	POW-0003	BRACKET MONITOR 26' RIGHT
3	KR-0008	BRACKET
4	280-5112	BUSH FOR TV
5	280-5113	COLLAR FOR TV
6	280-5114	SPACER 6.4-25x2
101	200-5125-15	ASSY CLR DSPL 26 TYPE 15K 100V
	200-5112-15	ASSY CLR DSPL 26 TYPE 15K 100V
201	010-0408-F	S-TITE SCR PH W/F M4x8
202	030-0630	HEX BOLT M6x30
203	061-0006	SPR WSHR M6
204	050-0006	HEX NUT M6

⑮ ASSY SW PLATE (POW-2046)

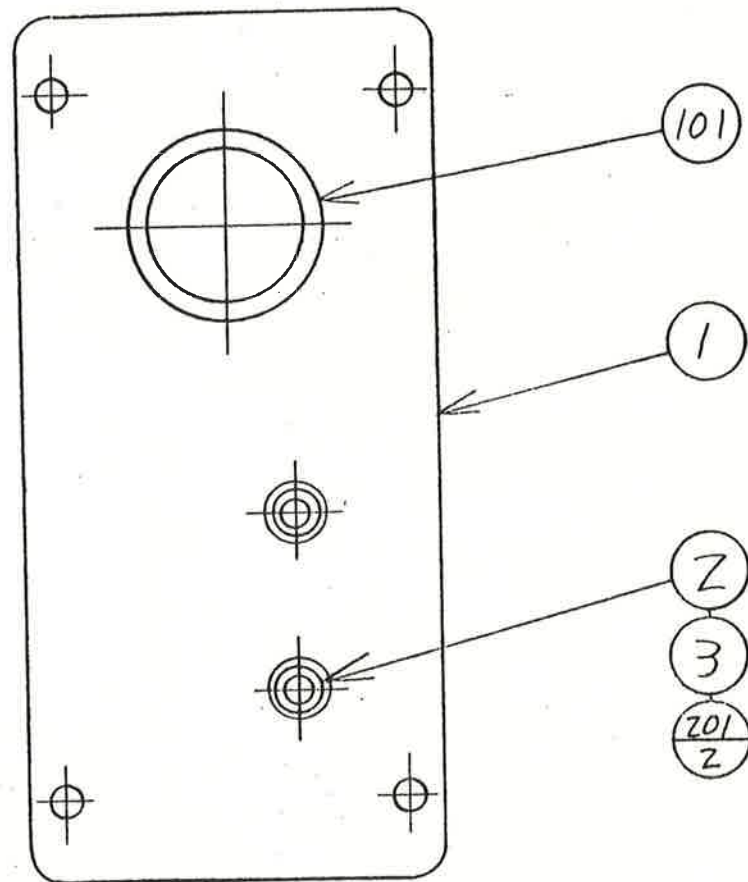

ITEM NO.	PART NO.	DESCRIPTION
1	POW-2047	SW PLATE
2	839-0098	MINI JACK BOARD
3	280-0479	SPACER TUBE 6
4	421-7314	STICKER START
5	421-7315	STICKER EARPHONE
101	509-5218	PUSH BTN SW IT YELLOW W/LAMP
201	000-0312-FS	M SCR PH W/FS M3x12

⑯ ASSY BASE (POW-3000)

(D-1/3)

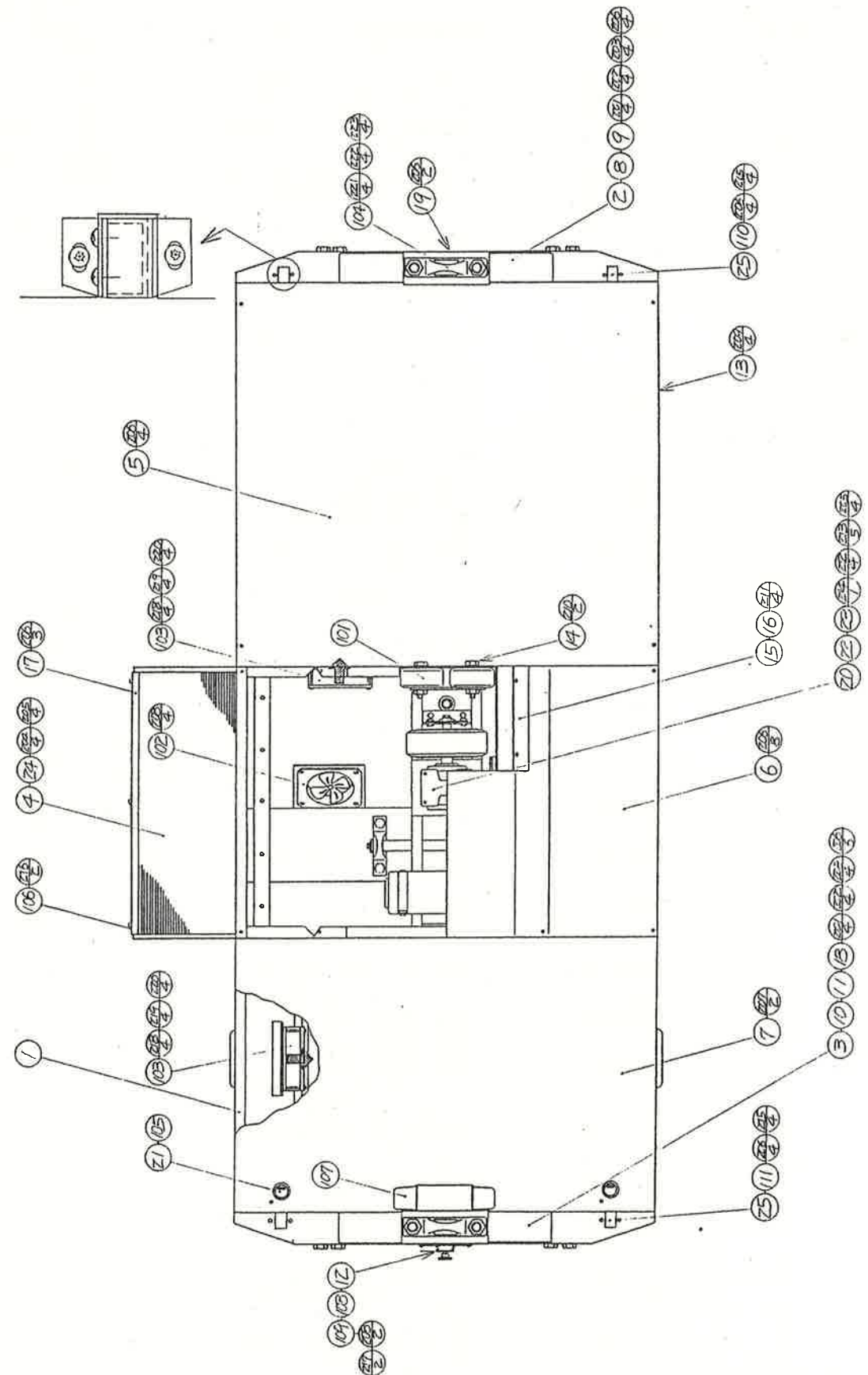

16

ASSY BASE (POW-3000)

(D-2/3)

ITEM NO.	PART NO.	DESCRIPTION
1	POW-3001	BASE
2	POW-3002	PILLAR FRONT
3	POW-3003	PILLAR REAR
4	POW-3004	STEP BOX
5	POW-3005	BASE COVER FRONT
6	POW-3006	BASE COVER CENTER
7	POW-3007	BASE COVER REAR
8	POW-3008	WIRE COVER FL
9	POW-3009	WIRE COVER FR
10	POW-3010	WIRE COVER RL
11	POW-3011	WIRE COVER RR
12	POW-3012	VOLUME BRKT BANK
13	POW-3013	BANDAGE
14	POW-3014	WHEEL AXLE
15	POW-3015	GUARD RUBBER
16	POW-3016	GUARD PLATE
17	POW-3017	MAT HOLDER
18	POW-3018	WIRE GUARD
19	POW-3200	ASSY AC UNIT
20	POW-3100	ASSY MOTOR UNIT
21	DP-1167	TNG LGK
22	TX-2017	COMP SPRING
23	TX-2018	SPRING GUIDE
24	POW-3019	STEP MAT
25	POW-3020X	SENSOR BRKT
101	601-6124	RUBBER WHEEL ϕ 75
102	260-0023	FAN MOTOR AC 100V
103	260-0011-02	AXIAL FLOW FAN AC 100V 50-60 HZ
104	100-5044	BEARING ϕ 30
105	220-5253	MAGNETIC LOCK MASTER W/O KEY
106	601-5531	LEG ADJUSTER
107	601-5778	RUBBER STOPPER
108	220-5130	VOL CONT B-5K OHM
109	601-5415	GEAR 20
110	370-5019-01	BEAM SENSOR
111	370-5019-02	BEAM SENSOR
201	039-0039	HEX BLT BLK M10x80
202	069-0061	FLT WSHR BLK M10
203	069-0063	SPR WSHR BLK M10
204	039-0046	HEX BOLT M10x20
205	061-0010	SPR WSHR M10
206	008-0408	TMP PRF SCR TH M4x8
207	000-0430	M SCR PH M4x30
208	000-0410-FS	M SCR PH W/FS M4x10
209	051-0004	FLG NUT M4
210	050-0008	HEX NUT M8
211	008-0416	TMP PRF SCR TH M4x16
212	039-0008	HEX BLT M10x30
213	060-0010	FLT WSHR M10
214	039-0033	HEX BLT S=30 BLK M10x90
215	008-0420	TMP PRF SCR TH M4x20
216	050-0010	HEX NUT M10
217	028-0014	SET SCR HEX SKT M4x4
218	000-0450	M SCR PH M4x50

16

ASSY BASE (POW-3000)

(D-3/3)

ITEM NO.	PART NO.	DESCRIPTION
219	060-0004	FLT WSHR M4
220	061-0004	SPR WSHR M4
221	059-0016	HEX NUT M14
222	069-0019	SPR WSHR M14
223	069-0045	FLT WSHR M14

⑰

ASSY MOTOR UNIT (POW-3100)

(D-1/2)

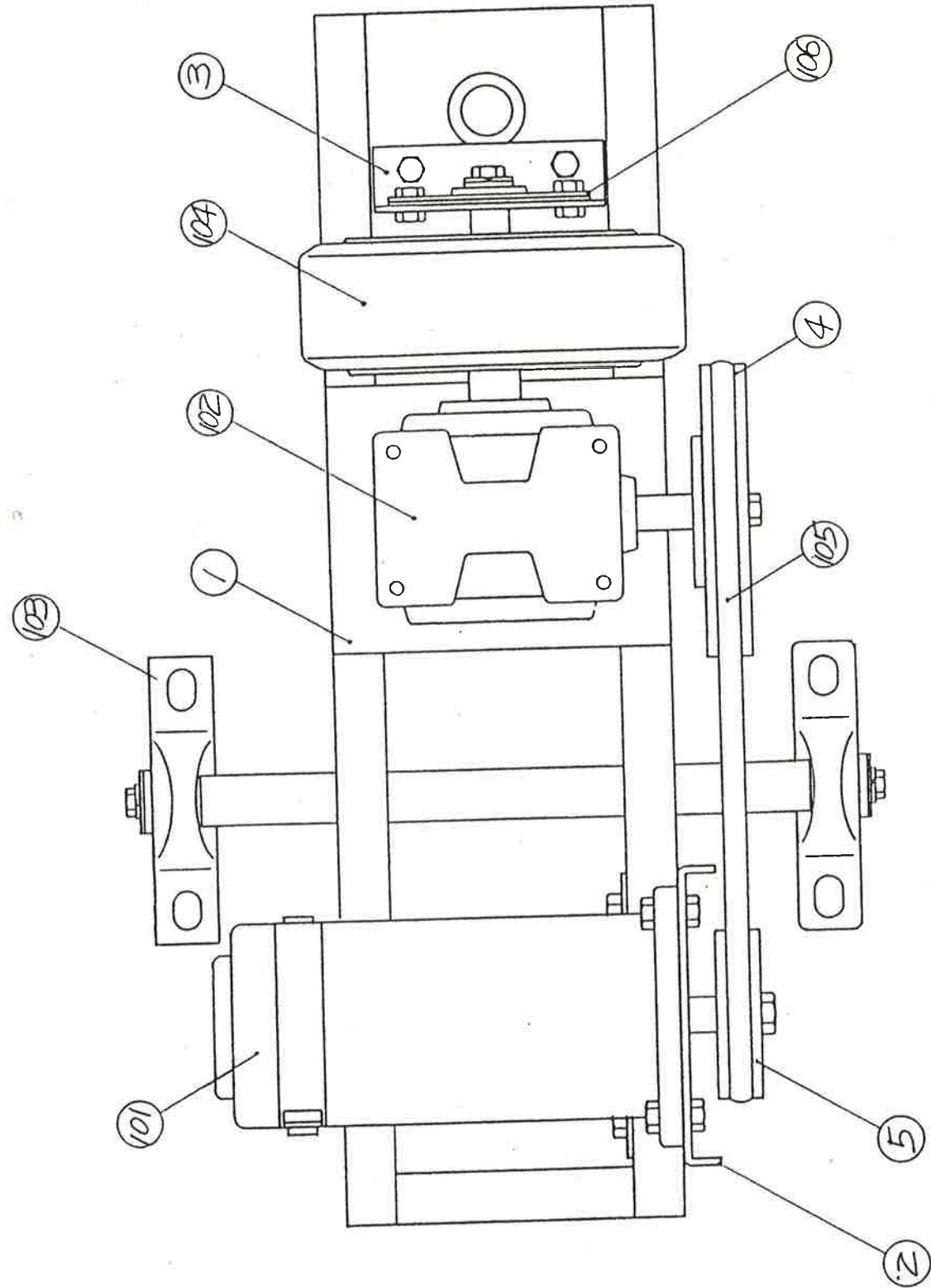

⑰

ASSY MOTOR UNIT (POW-3100)

(D-2/2)

ITEM NO.	PART NO.	DESCRIPTION
1	POW-3101	MECHA BASE
2	POW-3102	MOTOR BRACKET
3	POW-3103	PILLOW BRACKET
4	POW-3105	DRIVEN PULLY M
5	POW-3108	DRIVE PULLY M
	POW-3109	ASSY MOTOR JANOME
101	350-5133	MOTOR DC 80V W/ENCODER
102	350-5138	WORM SPEED REDUSER 1/40
103	100-5078	BEERING \varnothing 15
104	601-6113	RUBBER WHEEL
105	350-5139	V BELT
	350-5141	V BELT
106	100-5045	BEERING \varnothing 15

⑱ ASSY MOTOR JANOME (POW-3109)

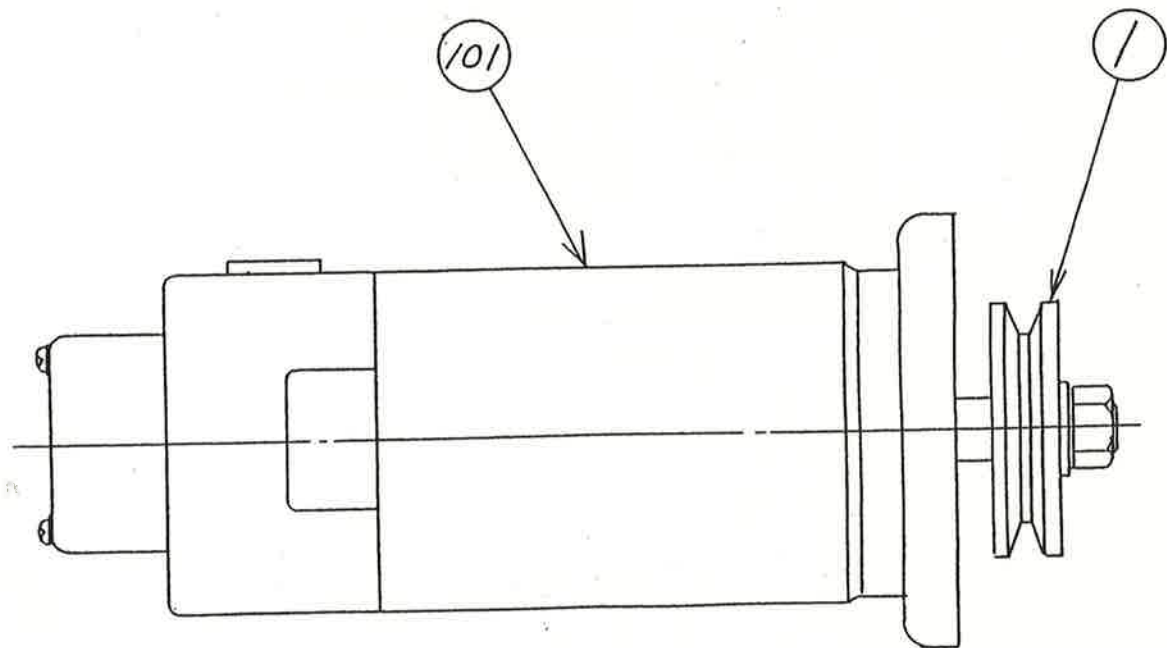

ITEM NO.	PART NO.	DESCRIPTION
1	POW-3107	DRIVE PULLEY S
101	350-5134	MOTOR DC 80V W/ENCODER

⑲ ASSY AC UNIT (POW-3200)

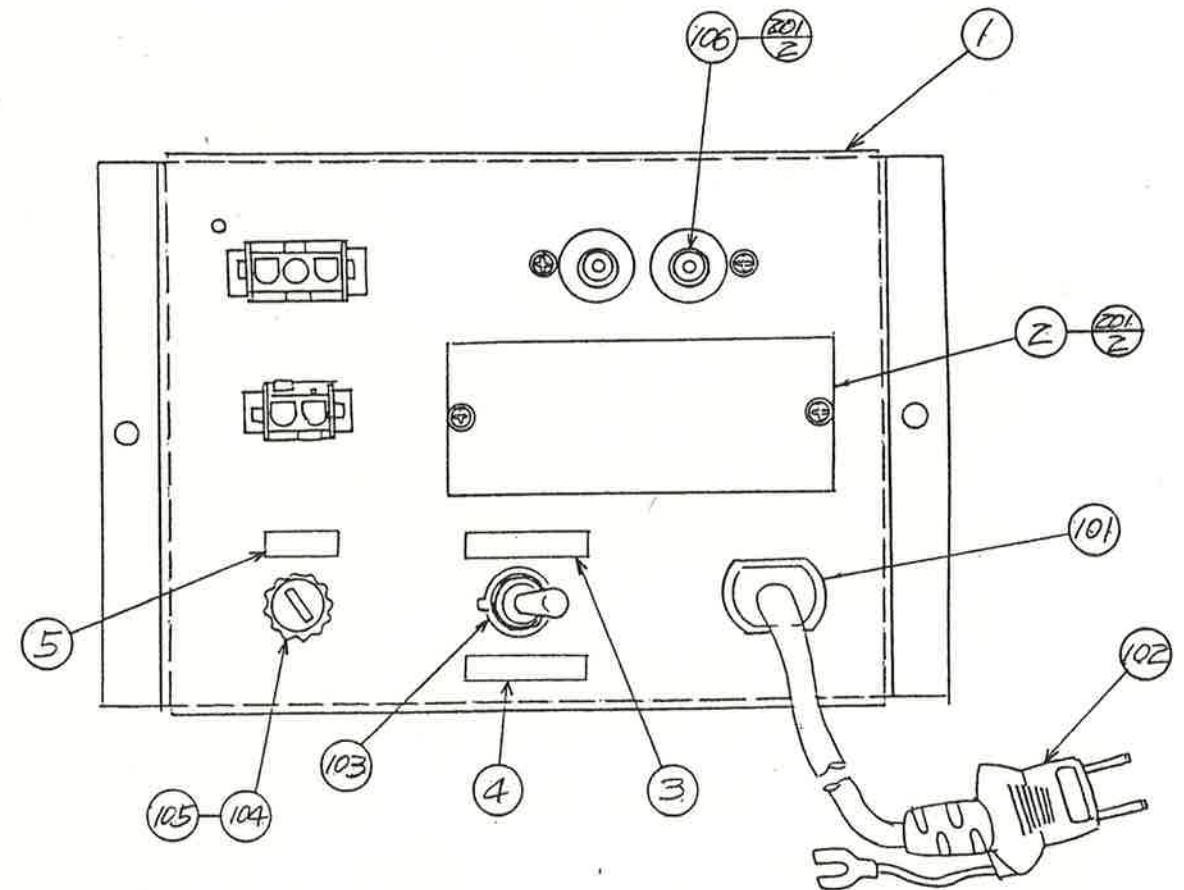

ITEM NO.	PART NO.	DESCRIPTION
1	POW-3201	AC UNIT BRACKET
2	POW-3202	AC BANDAGE
3	421-6950	STICKER MAIN SW
4	421-6592	STICKER ON-OFF
5	421-6595-09	STICKER 15A
101	280-0418	BUSHING STRAIN RELIEF 8.4
102	600-5500	CABLE & PLUG ASSY 15A W/EARTH
103	509-5234	SW TOGGLE 25A
104	514-5030	FUSE HOLDER
105	514-0037	FUSE 15A 6.4x30mm
106	210-5037	2P PHONO JACK
201	010-0306-F	S-TITE SCR PH W/F M3x6

20 ASSY PWR SPLY MAIN (POW-4000)

(D-1/2)

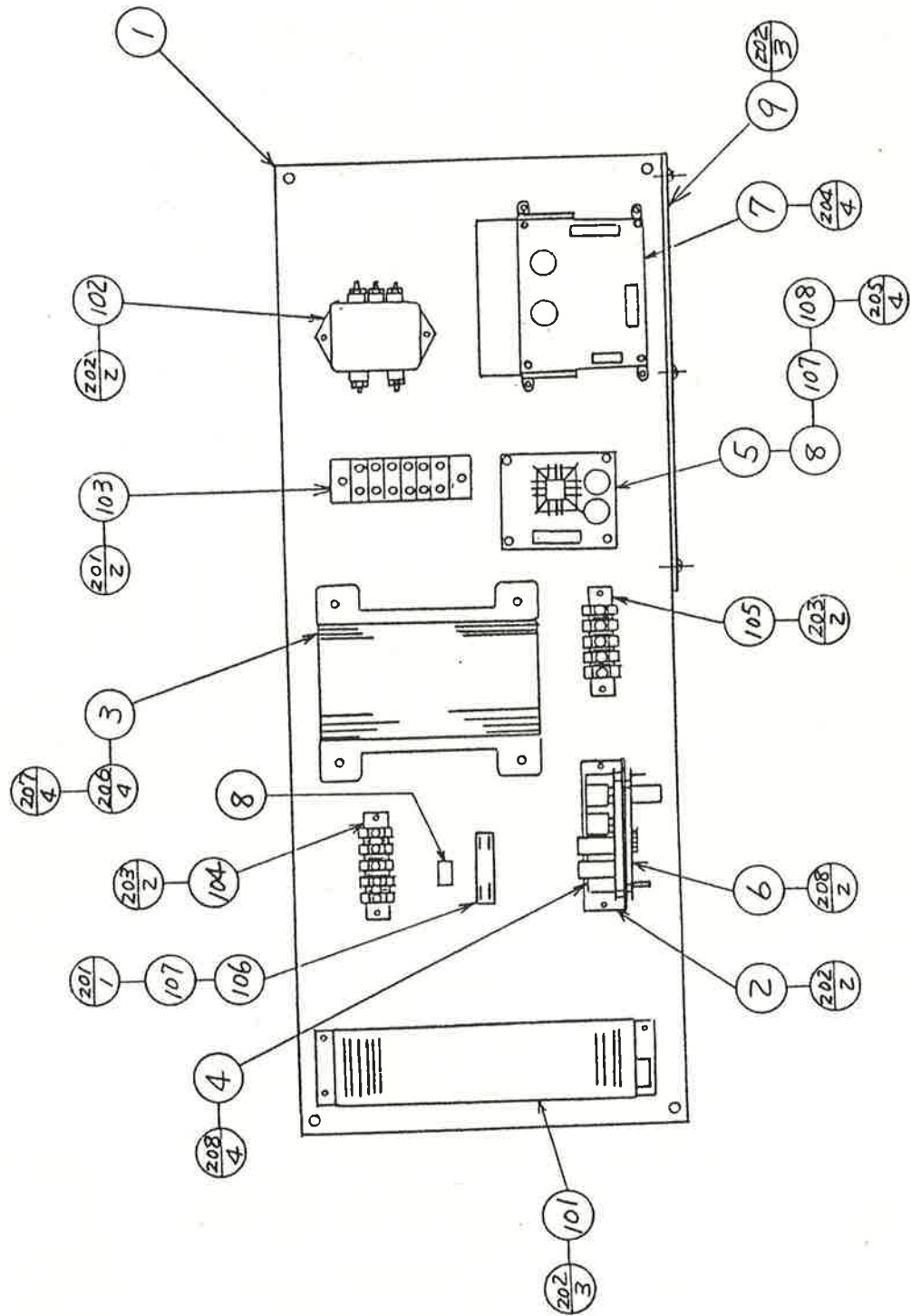

20 ASSY PWR SPLY MAIN (POW-4000)

(D-2/2)

ITEM NO.	PART NO.	DESCRIPTION
1	POW-4001	WOODEN BASE
2	POW-4002X	BD BRACKET
3	560-5133	PWR XFMR 90-240V 18.5-18.5-100V
4	400-5070	DC/DC CONVERTER 12V 5A
5	839-0186	RECT BD DC 24V
6	839-0210	TR SUB BD POW
7	839-0035-01	PWR AMP DC 12V 10W
8	421-7207	STICKER FUSE INSTR
9	POW-4003	WIRE GUARD PLATE
101	400-5089	SW REGU AC 90-240V +5V 12A
102	270-5022	NOISE FILTER 20A
103	117-5168	TERMINAL 6P 20A
104	117-5167	TERMINAL 5P-2P×2 SHORT
105	117-5131	TERMINAL PLATE 5P
106	514-5028	FUSE HOLDER 1P W/COVER
107	514-0034	FUSE 5A 6.4×30mm
108	601-6095	FUSE COVER
109	280-0419	HARNESS LUG
201	010-0316-F	S-TITE SCR PH W/F M3×16
202	005-3516	W SCR RH 3.5×16
203	005-3513-F	W SCR RH W/F 3.5×13
204	005-3520	W SCR RH 3.5×20
205	006-3113	W SCR FH 3.1×13
206	029-0173	W SCR RH 2.7×25
207	000-0516	M SCR PH M5×16
208	069-0001	FLT WSHR 5.5×20×1.6
209	010-0320-F	S-TITE SCR PH W/F M3×20

22

ASSY TERMINAL BASE (POW-4200)

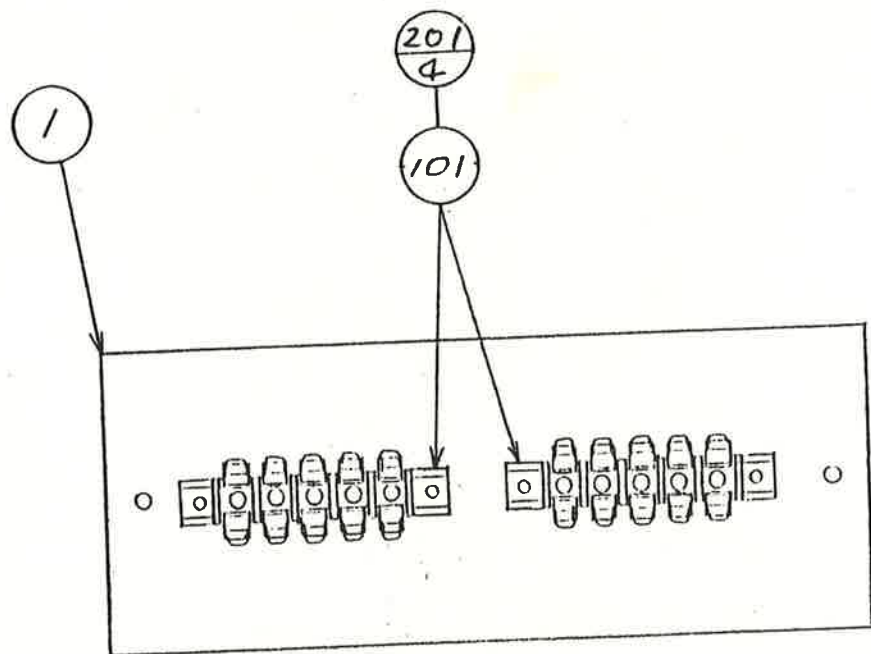

ITEM NO.	PART NO.	DESCRIPTION
1	POW-4201	WOODEN BASE
101	117-5166	TERMINAL 5P-5P SHORT
201	005-3520	W SCR RH 3.5x20

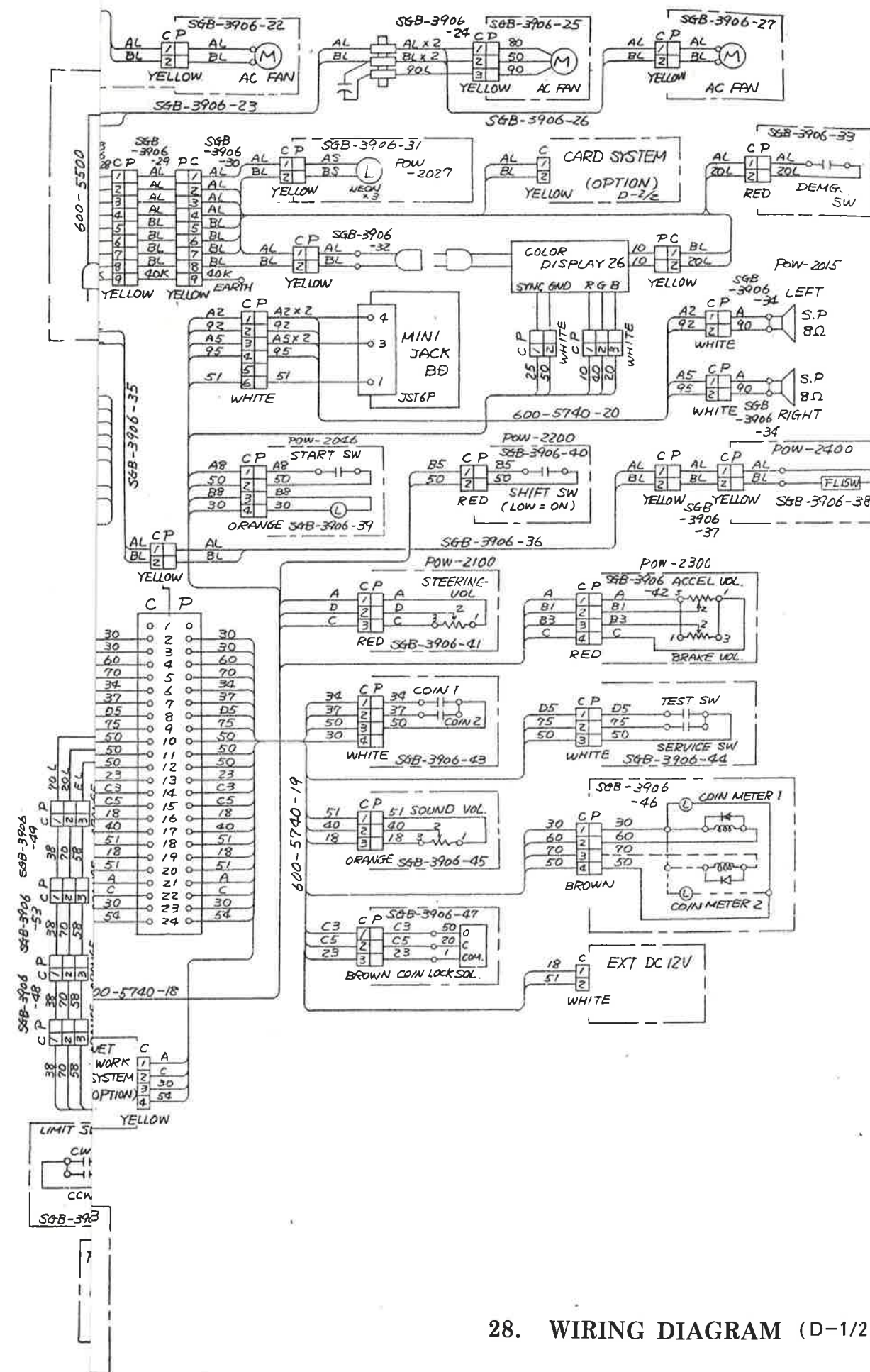

28. WIRING DIAGRAM (D-1/2)

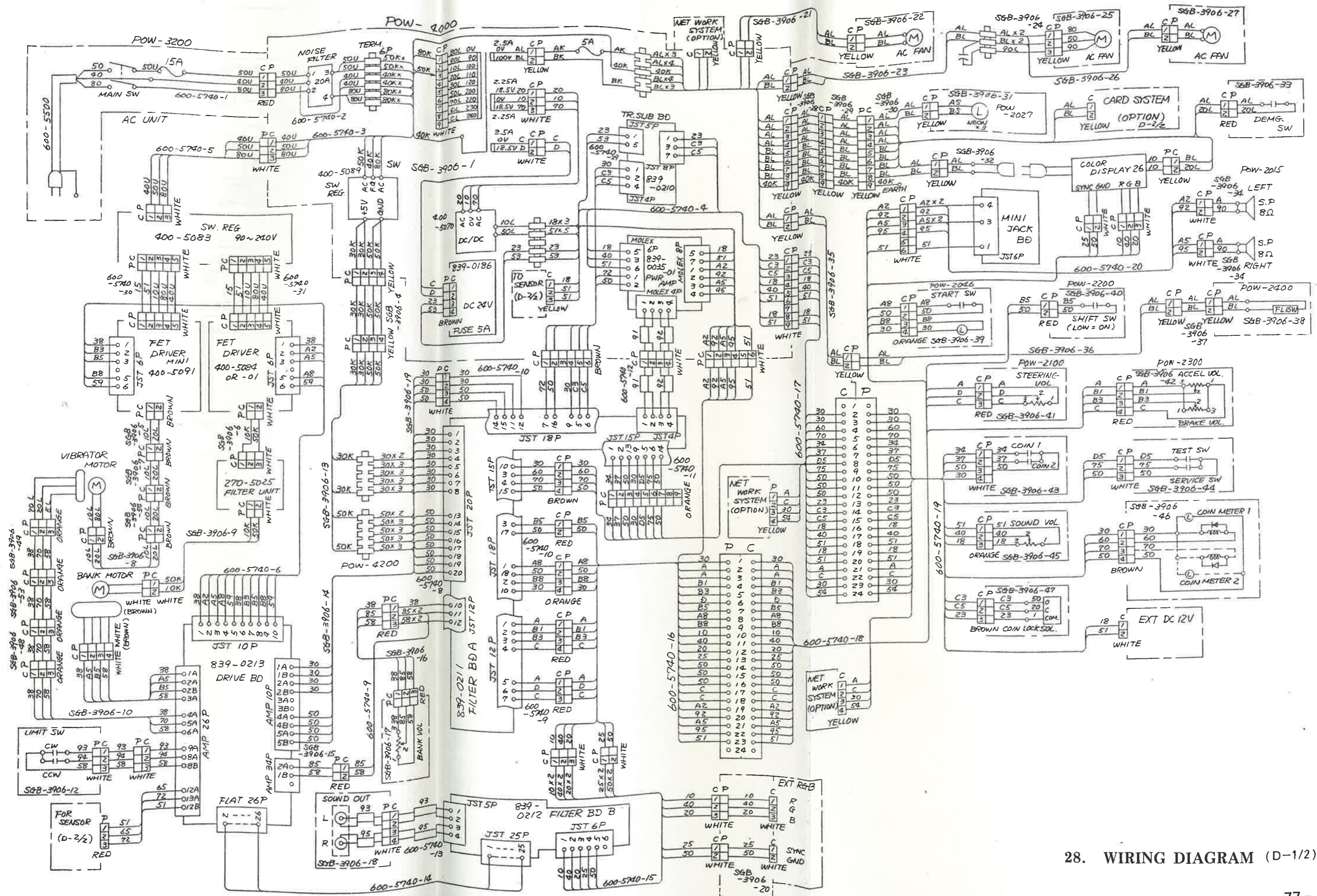

28. WIRING DIAGRAM (D-1/2)

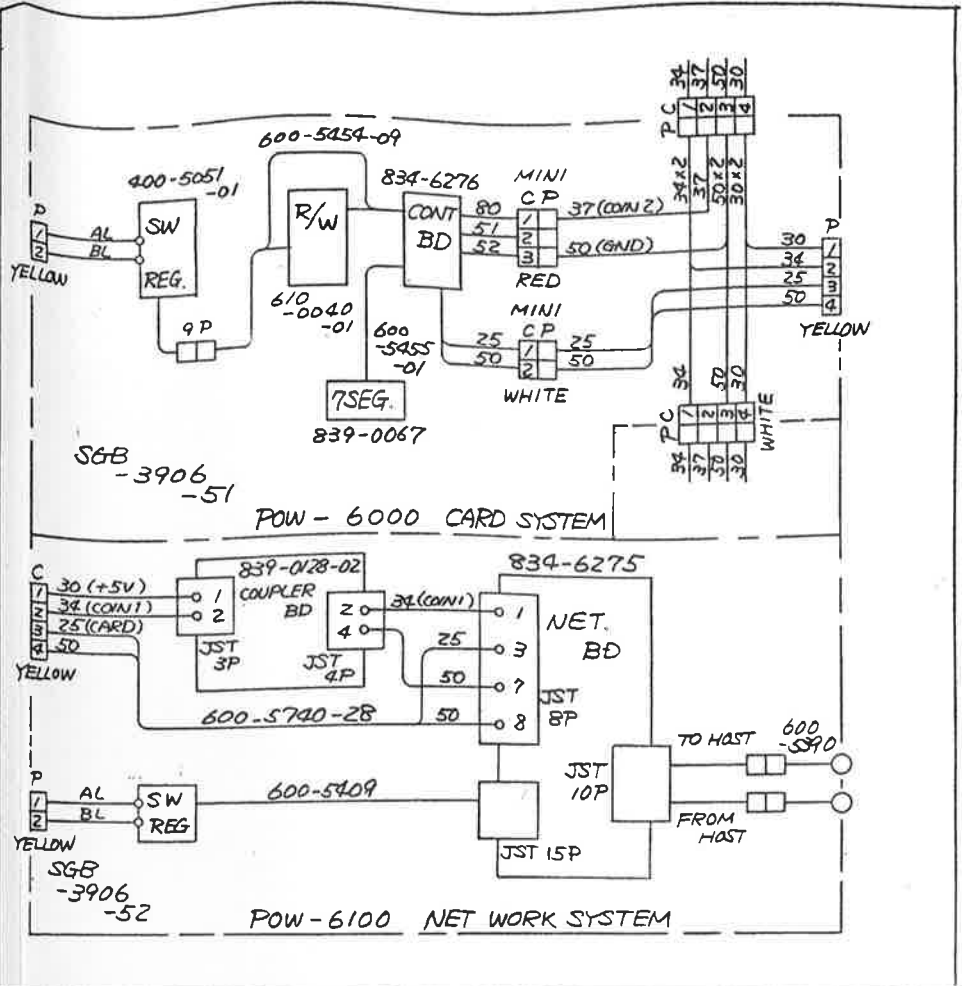
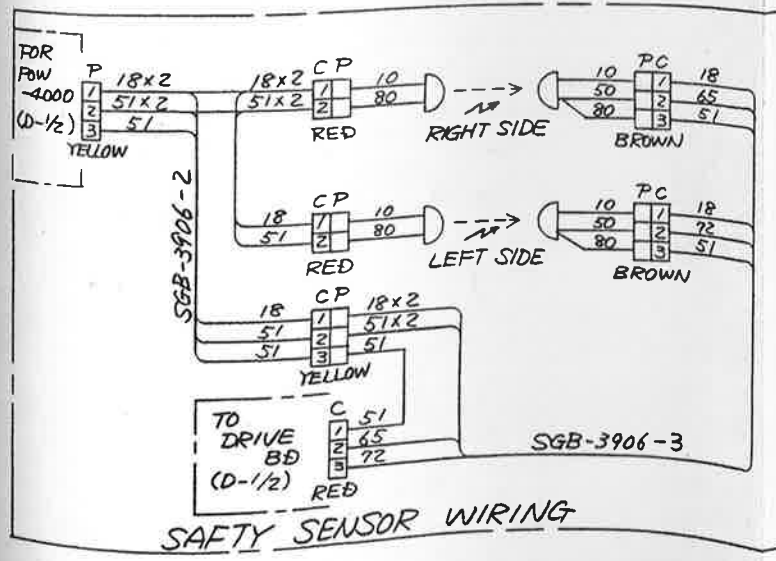
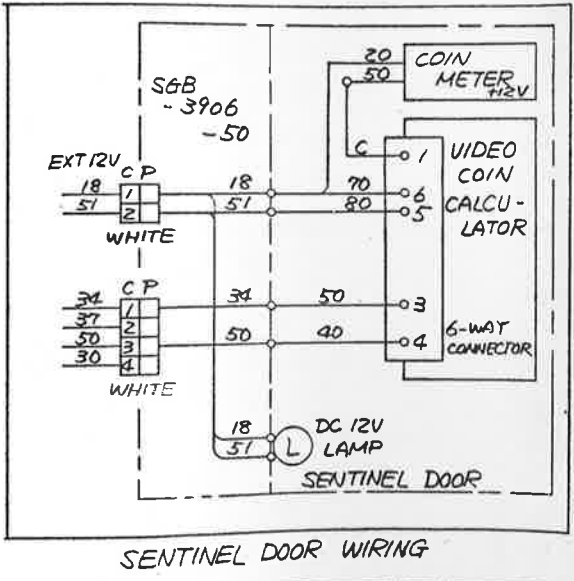
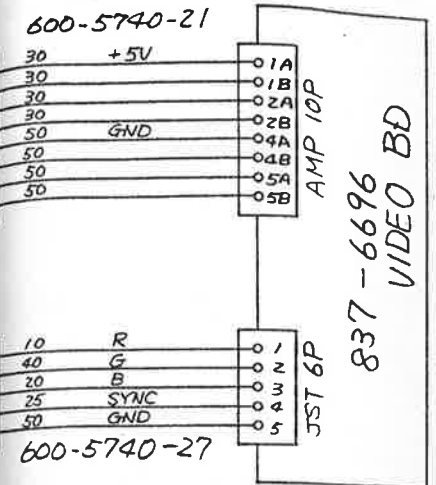
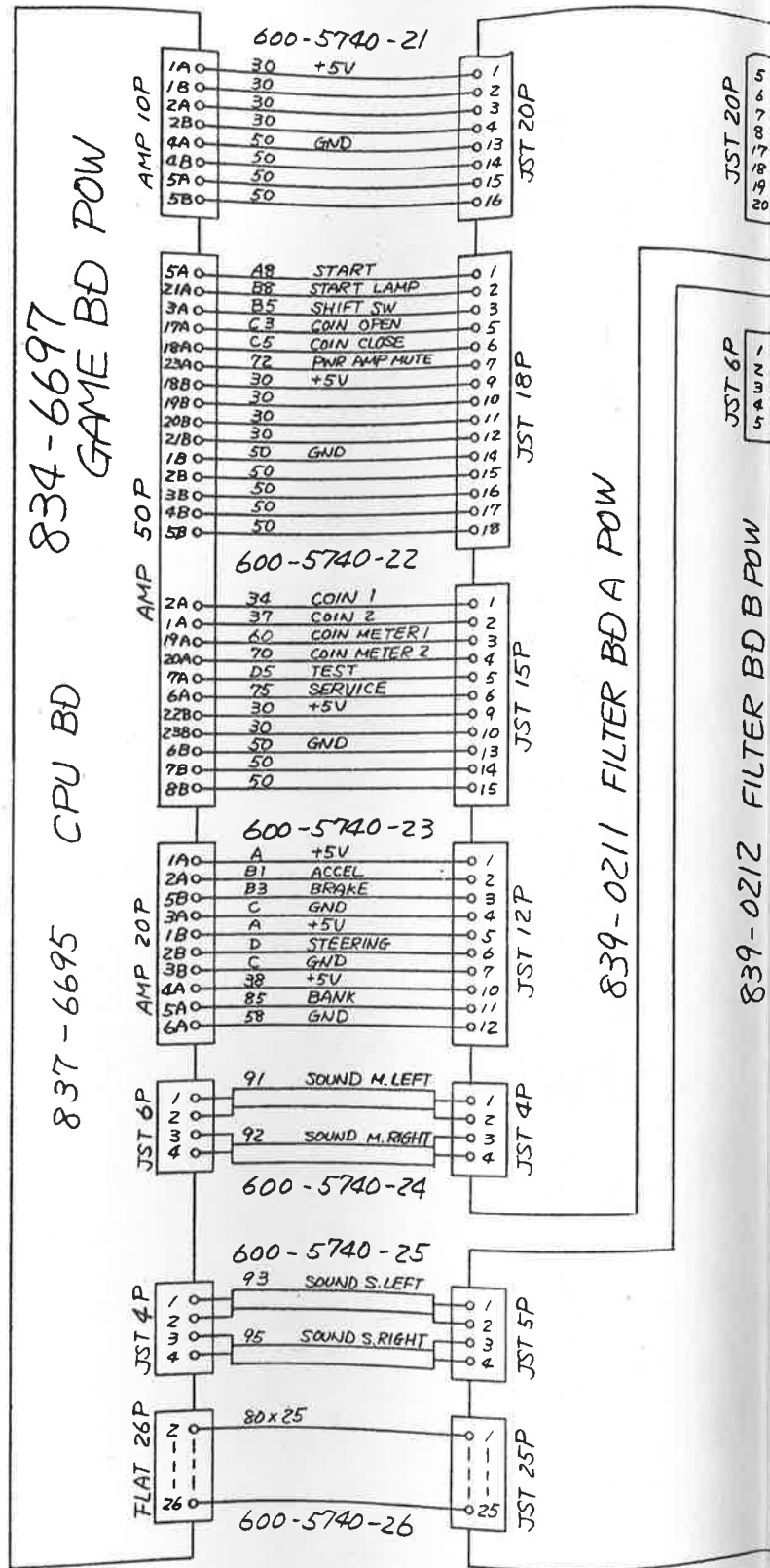

28. WIRING DIAGRAM (D-2/2)

SEGA ENTERPRISES, LTD.
No. 2-12, Haneda 1-chome
Ohta-ku, Tokyo 144, Japan
○ **Tel. : (03) 743 - 7438**
○ **FAX : (03) 743 - 5539**
○ **TLX : J22357 SEGASTAR**