

1ST PRINTING JAN. 01

SEGA



DX Type

Owner's Manual



SEGA ENTERPRISES, INC. USA

MANUAL NO. 420-6614-01

Warranty

Your new Sega Product is covered for a period of 90 days from the date of shipment. This certifies that the Printed Circuit Boards, Power Supplies and Monitor are to be free of defects in workmanship or materials under normal operating conditions. This also certifies that all Interactive Control Assemblies are to be free from defects in workmanship and materials under normal operating conditions. No other product in this machine is hereby covered.

Sellers sole liability in the event a warranted part described above fails shall be, at its option, to replace or repair the defective part during the warranty period. For Warranty claims, contact your Sega Distributor.

Should the Seller determine, by inspection that the product was caused by Accident, Misuse, Neglect, Alteration, Improper Repair, Installation or Testing, the warranty offered will be null and void.

Under no circumstances is the Seller responsible for any loss of profits, loss of use, or other damages.

This shall be the exclusive written Warranty of the original purchaser expressed in lieu of all other warranties expressed or implied. Under no circumstance shall it extend beyond the period of time listed above.

BEFORE USING THE PRODUCT, BE SURE TO READ THE FOLLOWING:

To maintain the safety:

To ensure the safe usage of the product, be sure to read the following before using the product. The following instructions are intended for the users, operators and the personnel in charge of the operation of the product. After carefully reading and sufficiently understanding the warning displays and cautions, handle the product appropriately. Be sure to keep this manual nearby the product or elsewhere convenient for referring to it when necessary.

Herein, explanations which require special attention are enclosed with dual lines. Depending on the potentially hazardous degrees, the terms of WARNING, CAUTION, etc. are used. Be sure to understand the contents of the displays before reading the text.



WARNING!

Indicates that mishandling the product by disregarding this warning will cause a potentially hazardous situation which can result in death or serious injury.



CAUTION!

Indicates that mishandling the product by disregarding this caution will cause a slight hazardous situation which can result in personal injury and or material damage.

For the safe usage of the product, the following pictographs are used:



Indicates "HANDLE WITH CARE." In order to protect the human body and equipment, this display is attached to places where the Owner's Manual and or Service Manual should be referred to.

○ Perform work in accordance with the instructions herein stated.

Instructions for work are explained by paying attention to the aspect of accident prevention. Failing to perform work as per the instructions can cause accidents. In the case where only those who have technical expertise should perform the work to avoid hazardous situation, the instructions herein state that the serviceman should perform such work.

○ Be sure to turn off power before working on the machine.

To prevent electric shock, be sure to turn off power before starting the work in which the worker touches the interior of the product. If the work is to be performed in the power-on status, the Instruction Manual herein always states to that effect.

○ Be sure to ground the Earth Terminal (this, however, is not required in the case where a power cord with earth is used).

This product is equipped with the Earth Terminal. When installing the product, Connect the Earth Terminal to the "accurately grounded indoor earth terminal" by using an earth wire. Unless the product is grounded appropriately, the user can be subject to electric shock. After performing repair, etc. for the Control equipment, ensure that the Earth Wire is firmly connected to the Control equipment.

○ Ensure that the Power Supply used is equipped with an Earth Leakage Breaker.

This product does not incorporate the Earth Leakage Breaker. Using a power supply which is not equipped with the Earth Leakage Breaker can cause a fire when earth leakage occurs.

○ Be sure to use fuses which meet the specified rating. (only for the machines which use fuses).

Using fuses exceeding the specified rating can cause a fire and electric shock.

○ **Specification changes (removal of equipment, conversion and addition) not designated by SEGA are not allowed.**

The parts of the product include warning labels for safety, covers for personal protection, etc. It is very hazardous to operate the product by removing parts and or modifying the circuits. Should doors, lids and protective parts be damaged or lost, refrain from operating the product, and contact where the product was purchased from or the office herein stated. SEGA shall not be held responsible for any accidents, compensation for damage to a third party, resulting from the specifications not designated by SEGA.

○ **Ensure that the product meets the requirements of appropriate Electrical Specifications.**

Before installing the product, check for Electrical Specifications. SEGA products have a nameplate on which Electrical Specifications are described. Ensure that the product is compatible with the power supply voltage and frequency requirements of the location. Using any Electrical Specifications different from the designated Specifications can cause a fire and electric shock.

○ **Install and operate the product in places where appropriate lighting is available, allowing warning labels to be clearly read.**

To ensure safety for the customers, labels and printed instructions describing potentially hazardous situation are applied to places where accidents can be caused. Ensure that where the product is operated has sufficient lighting allowing the warnings to be read. If any label is peeled off, apply it again immediately. Please place an order with where the product was purchased from or the office herein stated.

○ **When handling the Monitor, be very careful. (Applies only to the product w/monitor.)**

Some of the monitor (TV) parts are subject to high tension voltage. Even after running off power, some portions are still subject to high tension voltage sometimes. Monitor repair and replacement should be performed only by those technical personnel who have knowledge of electricity and technical expertise.

○ **Be sure to adjust the monitor (projector) properly. (Applies only to the product w/monitor.)**

Do not operate the product leaving on-screen flickering or blurring as it is. Using the product with the monitor not properly adjusted may cause dizziness or a headache to an operator, a player, or the customers.

○ **When transporting or reselling this product, be sure to attach this manual to the product.**

In the case where commercially available monitors and printers are used in this product, only the contents relating to this product are explained herein. Some commercially available equipment has functions and reactions not stated in this manual. Read this manual together with the specific Instruction Manual of such equipment.

- Descriptions herein contained may be subject to improvement changes without notice.
- The contents described herein are fully prepared with due care. However, should any question arise or errors be found, please contact SEGA.

INSPECTIONS IMMEDIATELY AFTER TRANSPORTING THE PRODUCT TO THE LOCATION.

Normally, at the time of shipment, SEGA products are in a status allowing for usage immediately after transporting to the location. Nevertheless, an irregular situation may occur during transportation. Before turning on power, check the following points to ensure that the product has been transported in a satisfactory status.

- Are there any dented portions or defects (cuts, etc.) on the external surfaces of the cabinet?
- Are Casters and Adjusters, damaged?
- Do the power supply voltage and frequency requirements meet with those of the location?
- Are all wiring connectors correctly and securely connected? Unless connected in the correct direction, connector connections can not be made accurately. Do not insert connectors forcibly.
- Do power cords have cuts and dents?
- Do the fuses used meet specified rating? Is the Circuit Protector in an energized status?
- Are all accessories available?
- Can all Doors and Lids be opened with the Accessory keys? Can Doors and Lids be firmly closed?

TABLE OF CONTENTS

BEFORE USING THE PRODUCT, BE SURE TO READ THE FOLLOWING:

TABLE OF CONTENTS

INTRODUCTION OF THE OWNER'S MANUAL

1. HANDLING PRECAUTIONS	1
2. PRECAUTIONS CONCERNING INSTALLATION LOCATION	2 - 3
3. OPERATION	4 - 8
4. NAME OF PARTS	9
5. ACCESSORIES	10 - 12
6. ASSEMBLING AND INSTALLATION	13 - 27
7. PRECAUTIONS TO BE HEEDED WHEN MOVING THE MACHINE	28 - 30
8. CONTENTS OF GAME	31 - 37
9. EXPLANATION OF TEST AND DATA DISPLAY	38 - 60
9 - 1 SWITCH UNIT AND COIN METER	39
9 - 2 SYSTEM TEST MODE	40 - 51
9 - 3 GAME TEST MODE	52 - 60
10. MAINTENANCE OF CONTROLLER MECHANISM UNIT	61 - 80
10 - 1 ADJUSTING/REPLACING THE ROLL-DIRECTION VOLUME CONTROL	61 - 66
10 - 2 ADJUSTING/REPLACING THE YAW-DIRECTION VOLUME CONTROL	67 - 70
10 - 3 GREASING	71 - 77
10 - 4 REPLACING THE ACCIDENT AVOIDANCE SYSTEM	78 - 80
11. PROJECTOR	81 - 94
11 - 1 CLEANING THE SCREEN	81
11 - 2 ADJUSTMENT OF TOSHIBA PROJECTOR	82 - 91
11 - 3 ADJUSTMENT OF MITSUBISHI PROJECTOR	92 - 94
12. COIN SELECTOR	95
13. REPLACING THE FLUORESCENT LAMP, AND LAMPS	96 - 103
14. PERIODIC INSPECTION TABLE	104
15. TROUBLESHOOTING	105 - 107
15 - 1 TABLE OF TROUBLESHOOTING	105 - 106
15 - 2 SYSTEM ERROR MESSAGES	107
16. GAME BOARD	108 - 110
16 - 1 REMOVING THE GAME BOARD	108 - 109
16 - 2 COMPOSITION OF GAME BOARD	110
17. DESIGN RELATED PARTS	111
18. PARTS LIST	112 - 156
19. WIRE COLOR CODE TABLE	157
20. WIRING DIAGRAM	158 - 160

SPECIFICATIONS

Installation space	: 1,315 mm (W) X 2, 845 mm (D) (51.8 in. X 112.0 in.)
Height	: 2,298 mm (90.4 in.)
Weight	: Approx. 535 kg. (1,179.5 lbs.)
Power, maximum current	: 570 W 6.45 A (AC 110V 50 Hz AREA) 560 W 6.30 A (AC 110V 60 Hz AREA) 555 W 5.70 A (AC 120V 60 Hz AREA) 570 W 3.50 A (AC 220V 50 Hz AREA) 560 W 3.40 A (AC 220V 60 Hz AREA) 560 W 3.35 A (AC 230V 50 Hz AREA) 555 W 3.25 A (AC 230V 60 Hz AREA) 565 W 3.25 A (AC 240V 50 Hz AREA) 555 W 3.15 A (AC 240V 60 Hz AREA)
For TAIWAN (TOSHIBA PROJECTION DISPLAY TYPE)	
Power, current	: 575 W 6.75A (MAX.) 360 W 4.10A (MIN.)
For TAIWAN (MITSUBISHI PROJECTION DISPLAY TYPE)	
Power, current	: 565 W 6.40A (MAX.) 345 W 3.95A (MIN.)
MONITOR	: 29 TYPE COLOR MONITOR

INTRODUCTION OF THE OWNERS MANUAL

This Owner's Manual is intended to provide detailed descriptions together with all the necessary information covering the general operation of electronic assemblies, electromechanicals, servicing control, spare parts, etc. as regards the product, **AIR TRIX**.

This manual is intended for the owners, personnel and managers in charge of operation of the product. Operate the product after carefully reading and sufficiently understanding the instructions. If the product fails to function satisfactorily, non-technical personnel should under no circumstances touch the internal system. Please contact where the product was purchased from.

Use of this product is unlikely to cause physical injuries or damages to property. However, where special attention is required this is indicated by a thick line, the word "IMPORTANT" and its sign in this manual.



IMPORTANT

Indicates that mishandling the product by disregarding this display can cause the product's intrinsic performance not to be obtained, resulting in malfunctioning.

SEGA ENTERPRISES, INC. (U.S.A.)/CUSTOMER SERVICE
45133 Industrial Drive, Fremont, California 94538, U.S.A.

Phone : (415) 701-6580

Fax : (415) 701-6594

DEFINITION OF LOCATION MAINTENANCE MAN AND SERVICEMAN



Non-technical personnel who do not have technical knowledge and expertise should refrain from performing such work that this manual requires the location's maintenance man or a serviceman to carry out, or work which is not explained in this manual. Failing to comply with this instruction can cause a severe accident such as electric shock.

Ensure that parts replacement, servicing & inspections, and troubleshooting are performed by the location's maintenance man or the serviceman. It is instructed herein that particularly hazardous work should be performed by the serviceman who has technical expertise and knowledge.

The location's maintenance man and serviceman are herein defined as follows:

"Location's Maintenance Man" :

Those who have experience in the maintenance of amusement equipment and vending machines, etc., and also participate in the servicing and control of the equipment through such routine work as equipment assembly and installation, servicing and inspections, replacement of units and consumables, etc. within the Amusement Facilities and or locations under the management of the Owner and Owner's Operators of the product.

Activities of Location's Maintenance Man :

Assembly & installation, servicing & inspections, and replacement of units & consumables as regards amusement equipment, vending machines, etc.

Serviceman :

Those who participate in the designing, manufacturing, inspections and maintenance service of the equipment at an amusement equipment manufacturer.

Those who have technical expertise equivalent to that of technical high school graduates as regards electricity, electronics and or mechanical engineering, and daily take part in the servicing & control and repair of amusement equipment.

Serviceman's Activities :

Assembly & installation and repair & adjustments of electrical, electronic and mechanical parts of amusement equipment and vending machines.

1. HANDLING PRECAUTIONS

When installing or inspecting the machine, be very careful of the following points and pay attention to ensure that the player can enjoy the game safely.

Non-compliance with the following points or inappropriate handling running counter to the cautionary matters herein stated can cause personal injury or damage to the machine.



- Before performing work, be sure to turn power off. Performing the work without turning power off can cause an electric shock or short circuit. In the case work should be performed in the status of power on, this manual always states to that effect.
- To avoid electric shock or short circuit, do not plug in or unplug quickly.
- To avoid electric shock, do not plug in or unplug with a wet hand.
- Do not expose Power Cords and Earth Wires on the surface, (floor, passage, etc.). If exposed, the Power Cords and Earth Wires are susceptible to damage. Damaged cords and wires can cause electric shock or short circuit.
- To avoid causing a fire or electric shock, do not put things on or damage Power Cords.
- When or after installing the product, do not unnecessarily pull the power cord. If damaged, the power cord can cause a fire or electric shock.
- In case the power cord is damaged, ask for replacement through where the product was purchased from or the office herein stated. Using the cord as is damaged can cause fire, electric shock or leakage.
- Be sure to perform grounding appropriately. Inappropriate grounding can cause an electric shock.
- Be sure to use fuses meeting specified rating. Using fuses exceeding the specified rating can cause a fire or electric shock.
- Completely make connector connections for IC BD and others. Insufficient insertion can cause an electric shock.
- Specification changes, removal of equipment, conversion and/or addition, not designated by SEGA are not permitted.
 - Failure to observe this may cause a fire or an electric shock. Non-compliance with this instruction can have a bad influence upon physical conditions of the players or the lookers-on, or result in injury during play.
 - SEGA shall not be held responsible for damage, compensation for damage to a third party, caused by specification changes not designated by SEGA.
- Be sure to perform periodic maintenance inspections herein stated.



- For the IC board circuit inspections, only the logic tester is allowed. The use of a multiple-purpose tester is not permitted, so be careful in this regard.
- The Projector is employed for this machine. The Projector's screen is susceptible to damage, therefore, be very careful when cleaning the screen. For details, refer to PROJECTOR.

2. PRECAUTIONS CONCERNING INSTALLATION

LOCATION



WARNING!

This product is an indoor game machine. Do not install it outside. Even indoors, avoid installing in places mentioned below so as not to cause a fire, electric shock, injury and or malfunctioning.

- Places subject to rain or water leakage, or places subject to high humidity in the proximity of an indoor swimming pool and or shower, etc.
- Places subject to direct sunlight, or places subject to high temperatures in the proximity of heating units, etc.
- Places filled with inflammable gas or vicinity of highly inflammable/volatile chemicals or hazardous matter.
- Dusty places.
- Sloped surfaces.
- Places subject to any type of violent impact.
- Vicinity of anti-disaster facilities such as fire exits and fire extinguishers.
- The operating (ambient) temperature range is from 5 Celsius to 40 Celsius. Only in the case a projector is employed, the temperature range is from 5 Celsius to 30 Celsius.

LIMITATIONS OF USAGE REQUIREMENTS



WARNING!

- Be sure to check the Electrical Specifications.
Ensure that this product is compatible with the location's power supply, voltage and frequency requirements.
A plate describing Electrical Specifications is attached to the product.
Non-compliance with the Electrical Specifications can cause a fire and electric shock.
- This product requires the Breaker and Earth Mechanisms as part of the location facilities. Using them in a manner not independent can cause a fire and electric shock.
- Ensure that the indoor wiring for the power supply is rated at 15A or higher (AC single phase 100 ~ 120V area), and 10A or higher (AC 220 ~ 240V area). Non-compliance with the Electrical Specifications can cause a fire and electric shock.
- Be sure to independently use the power supply equipped with the Earth Leakage Breaker. Using a power supply without the Earth Leakage Breaker can cause an outbreak of fire when earth leakage occurs.
- Putting many loads on one electrical outlet can cause generation of heat and a fire resulting from overload.
- When using an extension cord, ensure that the cord is rated at 15A or higher (AC 100 ~ 120V area) and 10A or higher (AC 220 ~ 240V area). Using a cord rated lower than the specified rating can cause a fire and electric shock.

OPERATION AREA



- For the operation of this machine, secure a minimum area of 1.9m (W) X 3m (D). In order to prevent injury resulting from the falling down accident during game play, be sure to secure the minimum area for operation.
- Be sure to provide sufficient space so as to allow this product's ventilation fan to function efficiently. To avoid machine malfunctioning and a fire, do not place any obstacles near the ventilation opening.
- SEGA shall not be held responsible for damage, compensation for damage to a third party, resulting from the failure to observe this instruction.



For transporting the machine into the location's building, the minimum necessary dimensions of the opening (of doors, etc.) are 1.3m(W) and 1.7m(H).

Electric current consumption

MAX. 6.45 A (AC 110V 50 Hz)
MAX. 6.30 A (AC 110V 60 Hz)
MAX. 5.70 A (AC 120V 60 Hz)
MAX. 3.50 A (AC 220V 50 Hz)
MAX. 3.40 A (AC 220V 60 Hz)
MAX. 3.35 A (AC 230V 50 Hz)
MAX. 3.25 A (AC 230V 60 Hz)
MAX. 3.25 A (AC 240V 50 Hz)
MAX. 3.15 A (AC 240V 60 Hz)
For TAIWAN
TOSHIBA projection display
MAX. 6.75 A
MITSUBISHI projection display
MAX. 6.40 A

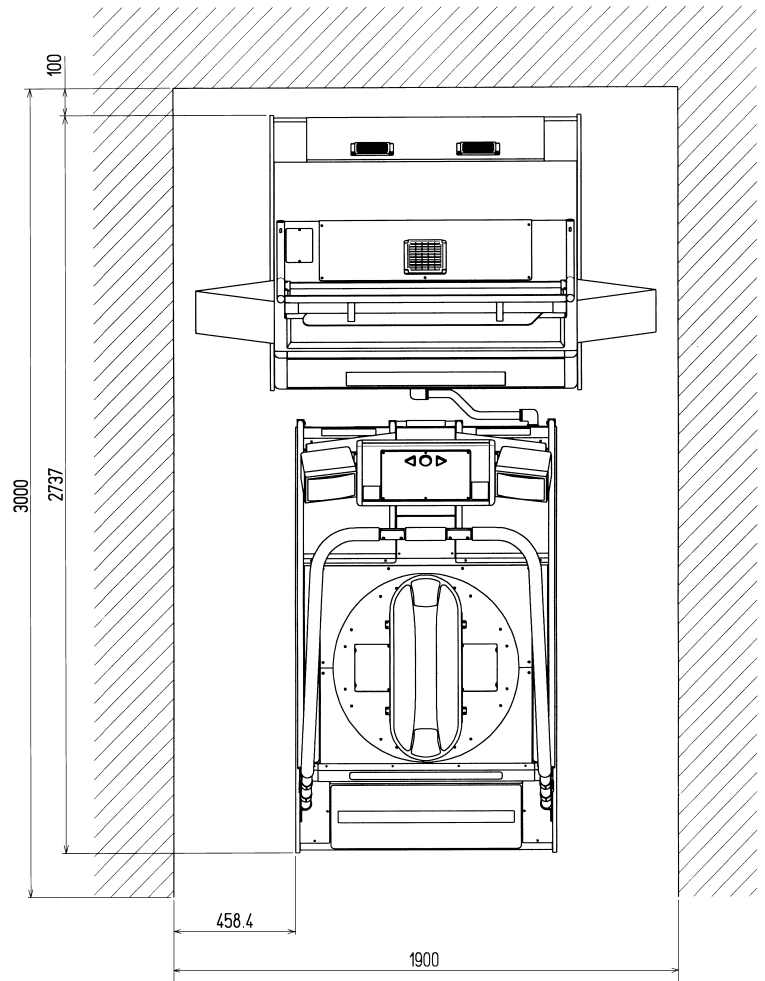

FIG. 2

3. OPERATION

PRECAUTIONS TO BE HEEDED BEFORE STARTING THE OPERATION

To avoid injury and trouble, be sure to constantly give careful attention to the behavior and manner of the visitors and players.



In order to avoid accidents, check the following before starting the operation:

- To ensure maximum safety for the players and the customers, ensure that where the product is operated has sufficient lighting to allow any warnings to be read. Operation under insufficient lighting can cause bodily contact with each other, hitting accident, and or trouble between customers.
- Be sure to perform appropriate adjustment of the monitor (projector). For operation of this machine, do not leave monitor's flickering or deviation as is. Failure to observe this can have a bad influence upon the players' or the customers' physical conditions.
- It is suggested to ensure a space allowing the players who feel sick while playing the game to take a rest.
- Check if all of the adjusters are in contact with the surface. If they are not, the Cabinet can move and cause an accident.

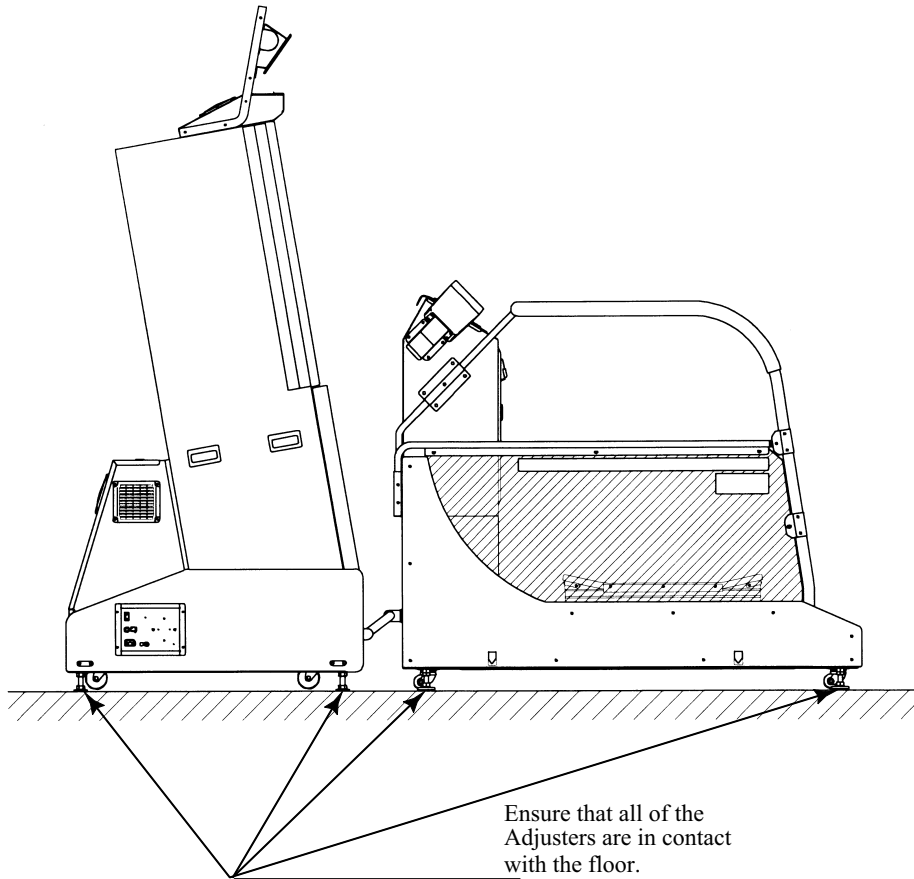



- Check to see if hazard preventive parts are damaged or omitted. Operating the product with the hazard preventive parts as is left in an irregular status will cause accidents.
- By carrying out a test run, check that the Skateboard can normally be locked and unlocked.

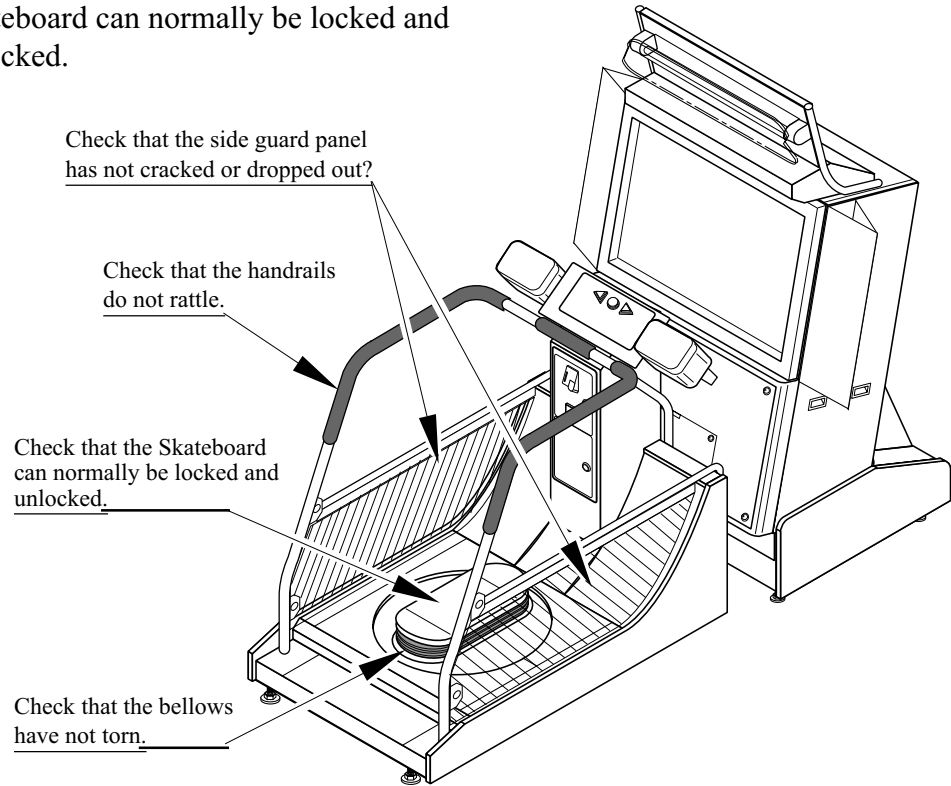

- Do not put any heavy item on this product. Placing any heavy item on the product can cause a falling down accident or parts damage.
- Do not climb on the product. Climbing on the product can cause falling down accidents. To check the top portion of the product, use a step.
- To avoid electric shock, check to see if door & cover parts are damaged or omitted.
- To avoid electric shock, short circuit and or parts damage, do not put the following items on or in the periphery of the product. Flower vases, flowerpots, cups, water tanks, cosmetics, and receptacles/containers/vessels containing chemicals and water.



To avoid injury, be sure to provide sufficient space by considering the potentially crowded situation at the installation location. Insufficient installation space can cause making bodily contact with each other, hitting accidents, and or trouble between customers.

PRECAUTIONS TO BE HEEDED DURING OPERATION (PAYING ATTENTION TO CUSTOMERS)

To avoid injury and trouble, be sure to constantly give careful attention to the behavior and manner of the visitors and players.



- To avoid injury and accidents, those who fall under the following categories are not allowed to play the game.
 - Those who need assistance such as the use of an apparatus when walking.
 - Those who have high blood pressure or a heart problem.
 - Those who have experienced muscle convulsion or loss of consciousness when playing video game, etc.
 - Those who have a trouble in the neck and or spinal cord.
 - Intoxicated persons.
 - Pregnant women or those who are in the likelihood of pregnancy.
 - Persons susceptible to motion sickness.
 - Persons whose act runs counter to the product's warning displays.
- A player who has never been adversely affected by light stimulus might experience dizziness or headache depending on his physical condition when playing the game. Especially, small children can be subject to those conditions. Caution guardians of small children to keep watch on their children during play.
- Instruct those who feel sick during play to have a medical examination.
- To avoid injury resulting from falling down and electric shock due to spilled drinks, instruct the player not to place heavy items or drinks on the product.
- To avoid electric shock and short circuit, do not allow customers to put hands and fingers or extraneous matter in the openings of the product or small openings in or around the doors.
- To avoid falling down and injury resulting from falling down, immediately stop the customer's leaning against or climbing on the product, etc.
- To avoid electric shock and short circuit, do not allow the customers to unplug the power plug without a justifiable reason.
- The player should be able to get on the Skate Board and hold on firmly to the Safety Bar. To avoid falling down accidents, instruct those who are shorter than 130 cm. not to play the game as the height of the Safety Bar is approximately 130 cm.
- Instruct those who wear high-heeled shoes to refrain from playing the game by explaining that playing game with high-heeled shoes is very likely to cause potentially hazardous situation.

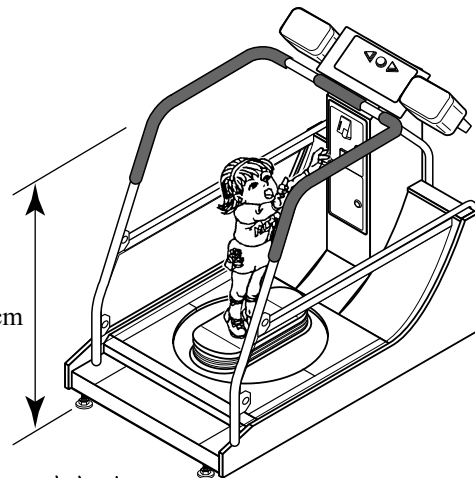



- To avoid injury from potential falling down accidents, be sure to instruct that only one person is allowed to play at a time.

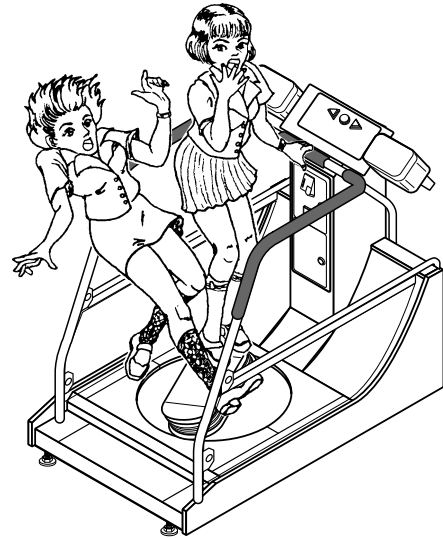

- Do not allow players to put any heavy item or beverages on the product. Falling down items can cause accidents and spilled beverages can cause electric shock.

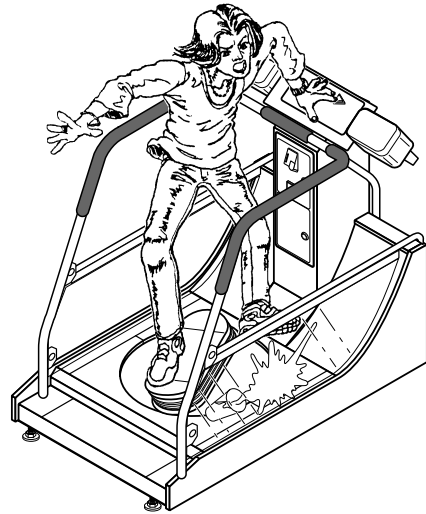

- Instruct the player to hold on firmly to the Safety Bar during game. Caution the customers who are most likely to cause injury by playing without holding the Safety Bar, for example.

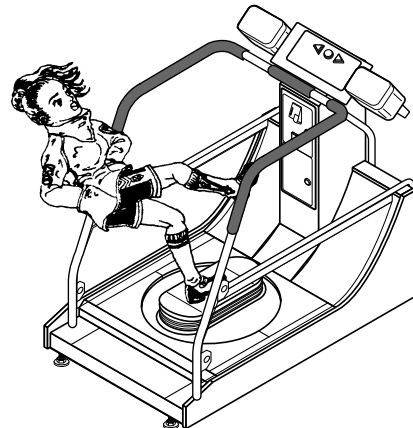
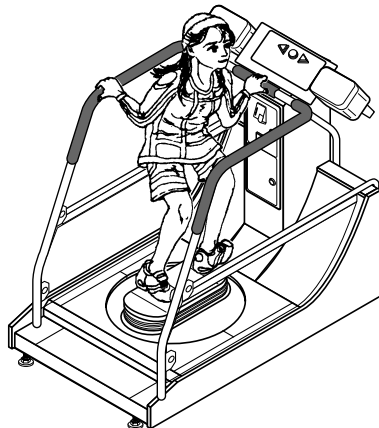



- To avoid injury, do not allow persons other than the player to access to the Rear Cabi during game play.

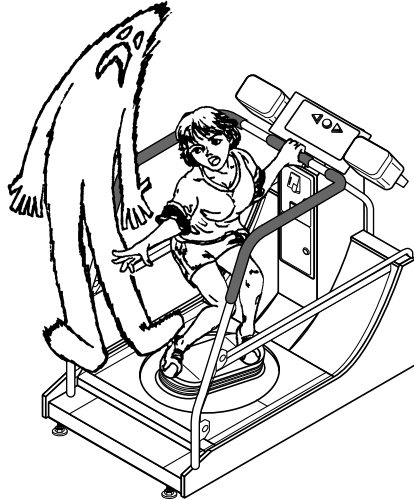

- Instruct the player to play by standing on both feet. Standing on one leg to play can cause injury.

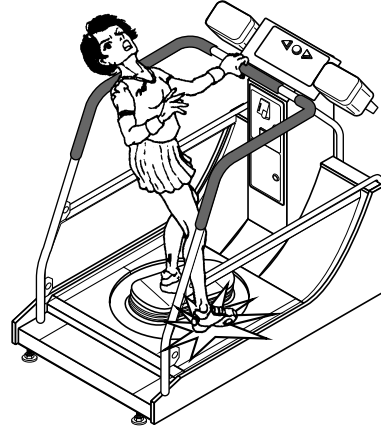

- Instruct the player not to put baggages, etc. on the Rear Cabi to avoid damaging such items.

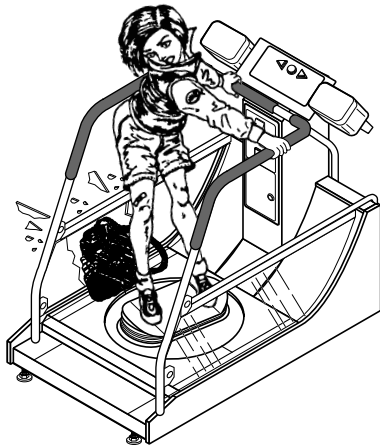

- Regarding this product, the weight of the player is limited to 150 kg. To avoid machine damage and injury due to machine damage, playing by those who are as heavy as 150 kg. or heavier is strictly prohibited.

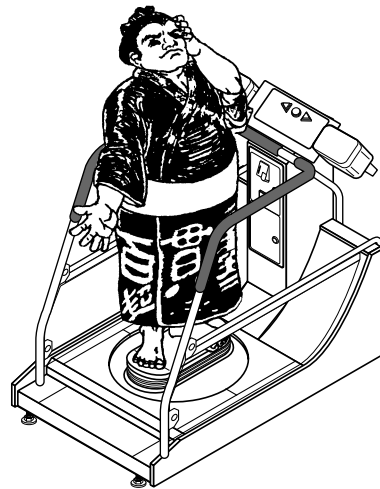

- Immediately stop such violent acts as hitting and kicking the product. Such violent acts can cause parts damage or falling down, resulting in injury due to fragments and falling down.

4. NAME OF PARTS

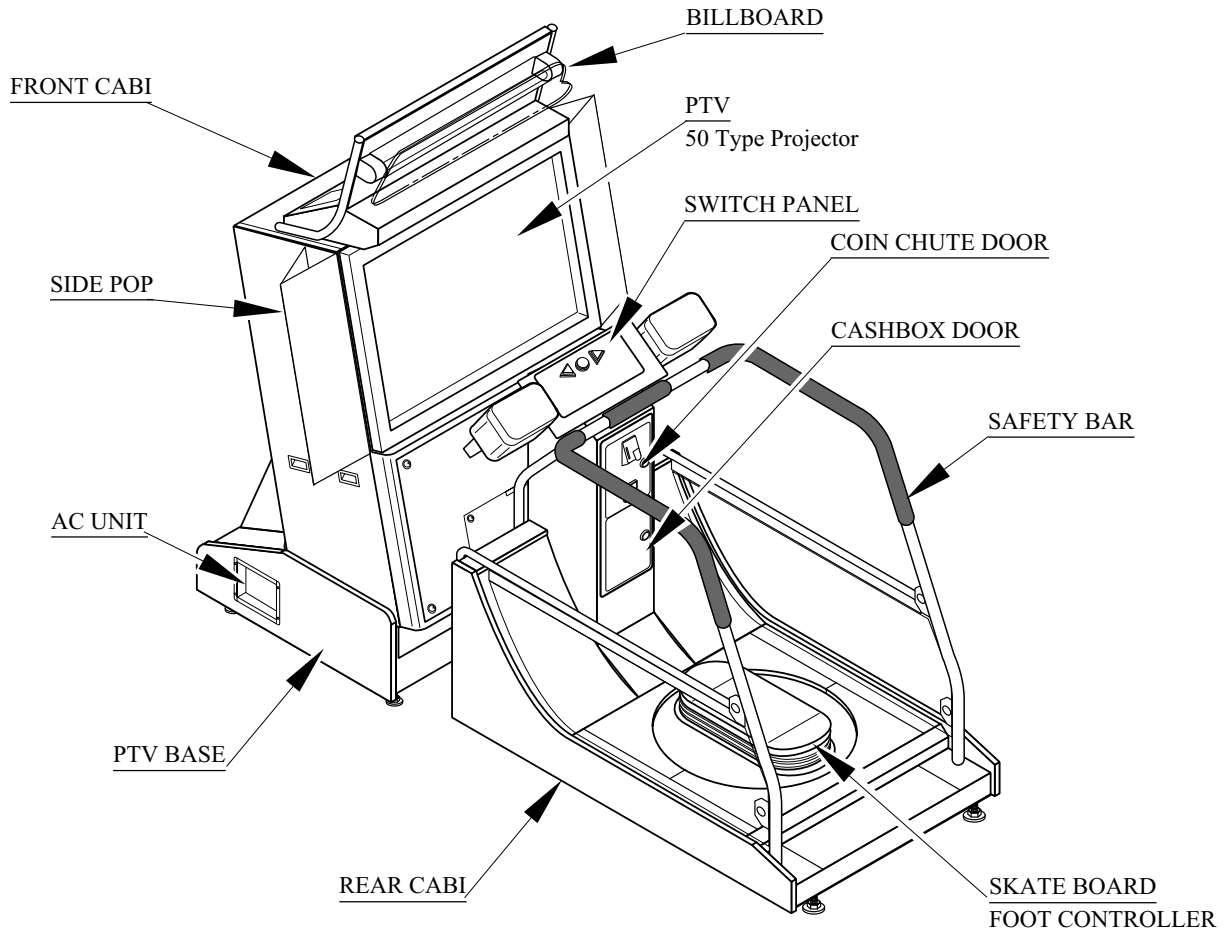

FIG. 4 OVERVIEW

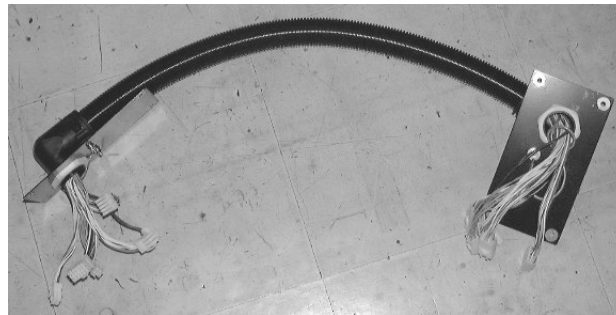

PHOTO 4 ASSY TUBE

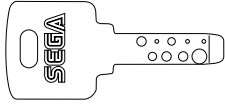
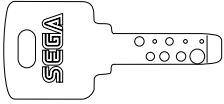
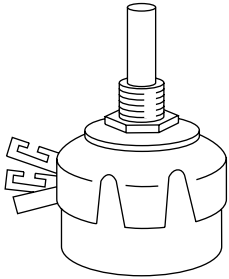

TABLE 4

	Width	X	Length	X	Height	Weight
PTV (50 type Projector)	1,140 mm	X	555 mm	X	1,670 mm	119 kg
PTV BASE (FRONT CABI)	1,190 mm	X	1,020 mm	X	785 mm	70 kg
BILLBOARD	1,128 mm	X	440 mm	X	400 mm	20 kg
REAR CABI	990 mm	X	1,620 mm	X	1,140 mm	256 kg
When assembled	1,740 mm	X	2,740 mm	X	2,325 mm	467 kg

5. ACCESSORIES

When transporting the machine, make sure that the following parts are supplied.

TABLE 5 ACCESSORIES

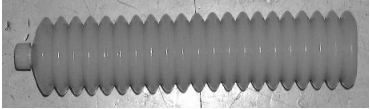
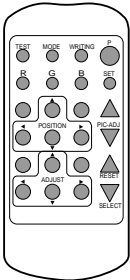
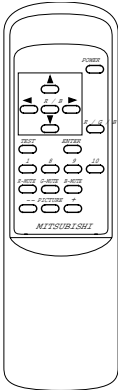
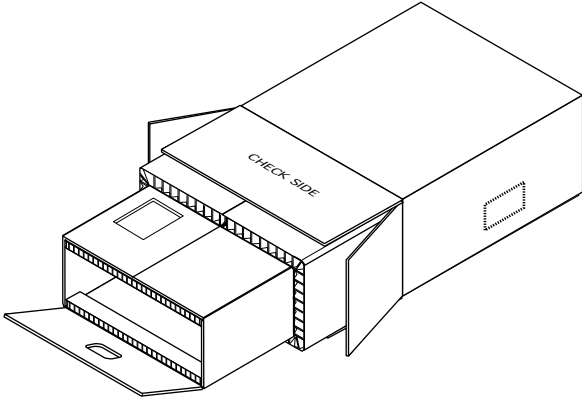
DESCRIPTION	OWNERS MANUAL	KEY MASTER	KEY
Part No. (Qty.) Note	420-6614-01 (1)	220-5576 (2)	(2)
Figures	If Part No. has no description, the Number has not been registered or can not be registered. Such a part may not be obtainable even if the customer desires to purchase it. Therefore, ensure that the part is in safekeeping with you.	For opening/closing the doors	For the CASHBOX DOOR
VOL CONT B-5K OHM 220-5484 (1)	GREASE GUN KH-120 540-0064 (1)		
Spare, see Section 10.	For greasing, see Section 10.	The Keys are inside the Coin Chute Door at the time of shipment from the factory.	
		LAMP 6V 3W (WEDGE BULB) 390-5160 (1)	
	GREASE ALBAMIA EP-1 400G (SPECIAL GREASE) 090-0275 (1)	Spare, refer to Section 13.	
	For greasing, see Section 10.		
			
TOSHIBA Remote Controller used for adjustment of the projector. See Section 11.	MITSUBISHI Remote Controller used for adjustment of the projector. See Section 11.	CARTON BOX 601-10642 (1)	Used for transporting the Game Board. Refer to FIG. 15.
200-5536(1)	200-5532(1)		
			
One of the above 2 types of Remote Controllers is used for the Projector.	The Remote Controller is attached to the Projector at the time of shipment.		

HOW TO USE THE CARTON BOX



- When asking for the replacement or repair of the product's Game Board (SEGA HIKARU), be sure to put the Game Board together with the Shield Case in a Carton Box. Otherwise, the request is not acceptable.
- Put the Shield Case in the Carton Box by paying attention to the correct direction as per the following instructions and as shown by the instructions printed on the Carton Box. Handling in an erroneous manner can damage the Game Board.
- Remove the Shield Case Brackets from the Shield Case and put the Shield Case in the Carton Box.

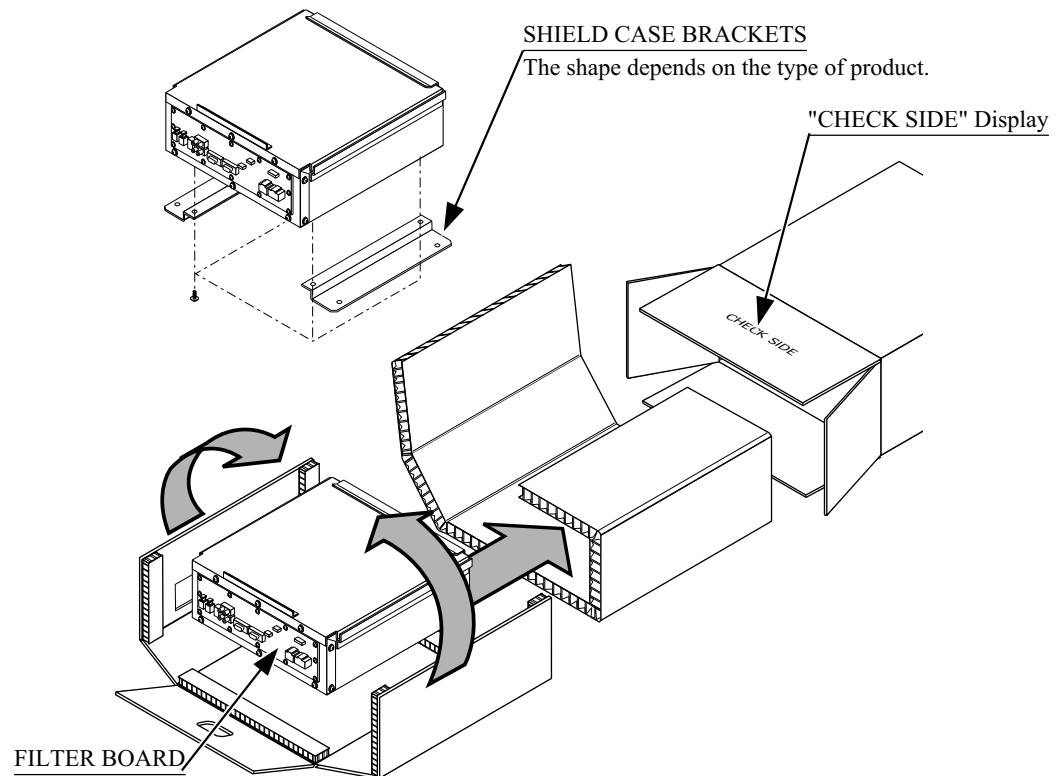

FIG. 5

Wrap the Shield Case with the packing material and put it in the Carton Box as shown. Putting it upside down or packing otherwise in the manner not shown can damage the Game Board and parts.

The following Table 5b lists the parts that had been separately packed when the product was shipped from the factory but are necessary when you use the product. These parts will be mounted on the product when installing and assembling it.

TABLE 5 b

SIDE POP
ATR-0003 (2)
see **4** of Section 6.

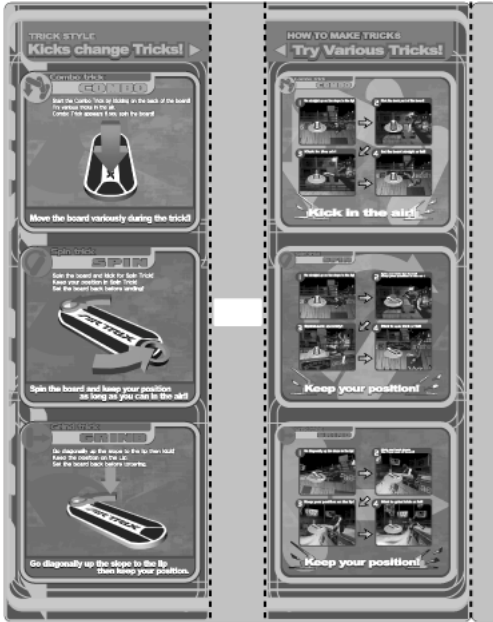

AC Cable (Power Cord)
600-6724
600-6729 (1) TAIWAN
600-6619 (1) HONG KONG
600-6618 (1) AC 220 ~ 240V AREA
600-6695 (1) USA

Used for installation, see **5** of Section 6.

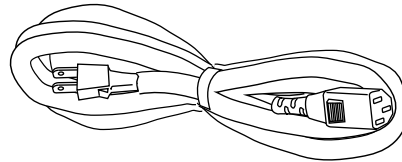

CORD CLAMP
280-5009-01 (1)

Used for securing the power cord.
see **5** of Section 6.

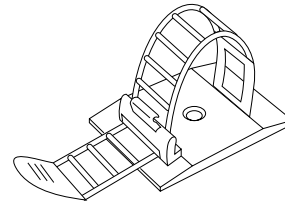

WIRE HARN EARTH W/LUG M6
600-6664-02 (1)

For TAIWAN.

Used for installation, see **5** of Section 6.

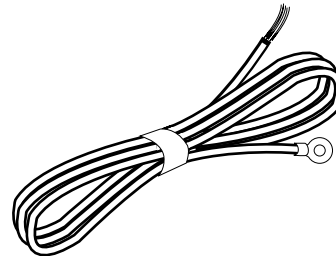

6. ASSEMBLING AND INSTALLATION



- Perform assembly work by following the procedure herein stated. Failing to comply with the instructions can cause electric shock hazard.
- Perform assembling as per this manual. Since this is a complex machine, erroneous assembling can cause an electric shock, machine damage and or not functioning as per specified performance.
- When assembling, be sure to use plural persons. Depending on the assembly work, there are some cases in which working by one person alone can cause personal injury or parts damage.
- Ensure that connectors are accurately connected. Incomplete connections can cause electric shock hazard.
- Be careful so as not to damage wirings. Damaged wiring can cause electric shock and short circuit hazards.
- Do not carelessly push the PTV. Pushing the PTV carelessly can cause the PTV to fall down.
- This work should be performed by the Location's Maintenance Man or Serviceman. Performing work by non-technical personnel can cause a severe accident such as electric shock. Failing to comply with this instruction can cause a severe accident such as electric shock to the player during operation.
- Provide sufficient space so that assembling can be performed. Performing work in places with narrow space or low ceiling may cause an accident and assembly work to be difficult.
- To perform work safely and avoid serious accident such as the cabinet's falling down, do not perform work in places where step-like grade differences, a ditch, or slope exist.



- When handling plastic parts, use care. Do not give a shock or apply excessive load to the fluorescent lamps and plastic parts. Failure to observe this can cause parts damage, resulting in injury due to fragments, cracks and broken pieces.
- To perform work safely and securely, be sure to prepare a step which is in a secure and stable condition. Performing work without using the step can cause violent falling down accidents.

When carrying out the assembly work, follow the procedure in the following 7-item sequence:

- 1 ASSEMBLING THE PTV (FRONT CABI)
- 2 WIRING CONNECTIONS BETWEEN THE CABINETS
- 3 SECURING IN PLACE (ADJUSTER ADJUSTMENT)
- 4 INTALLING THE SIDE POP
- 5 POWER SUPPLY, AND EARTH CONNECTION
- 6 TURNING POWER ON
- 7 ASSEMBLY CHECK

The master key (accessories) in addition to the tools such as a Phillips type screwdriver, Box nut screwdriver and wrench are required for the assembly work.

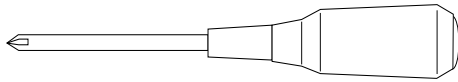

Phillips type screwdriver
(for M4,M5 screw)

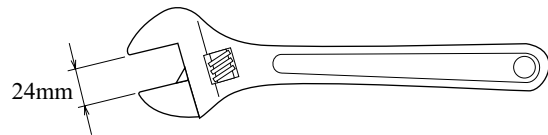

WRENCH (for M16 hexagon bolt)

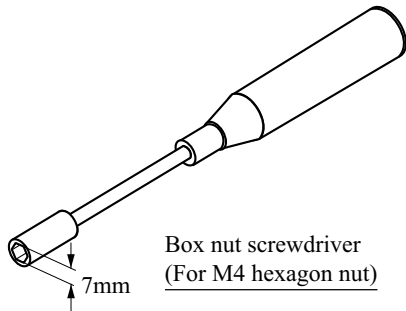

Box nut screwdriver
(For M4 hexagon nut)

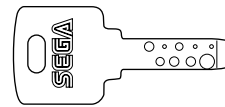

KEY MASTER

1

ASSEMBLING THE PTV (FRONT CABI)

- ① By using the specified screws, secure the 2 Mask Holders to the PTV ceiling.
- ② Insert the TV Mask from the underside as shown and secure with a total of 6 screws.

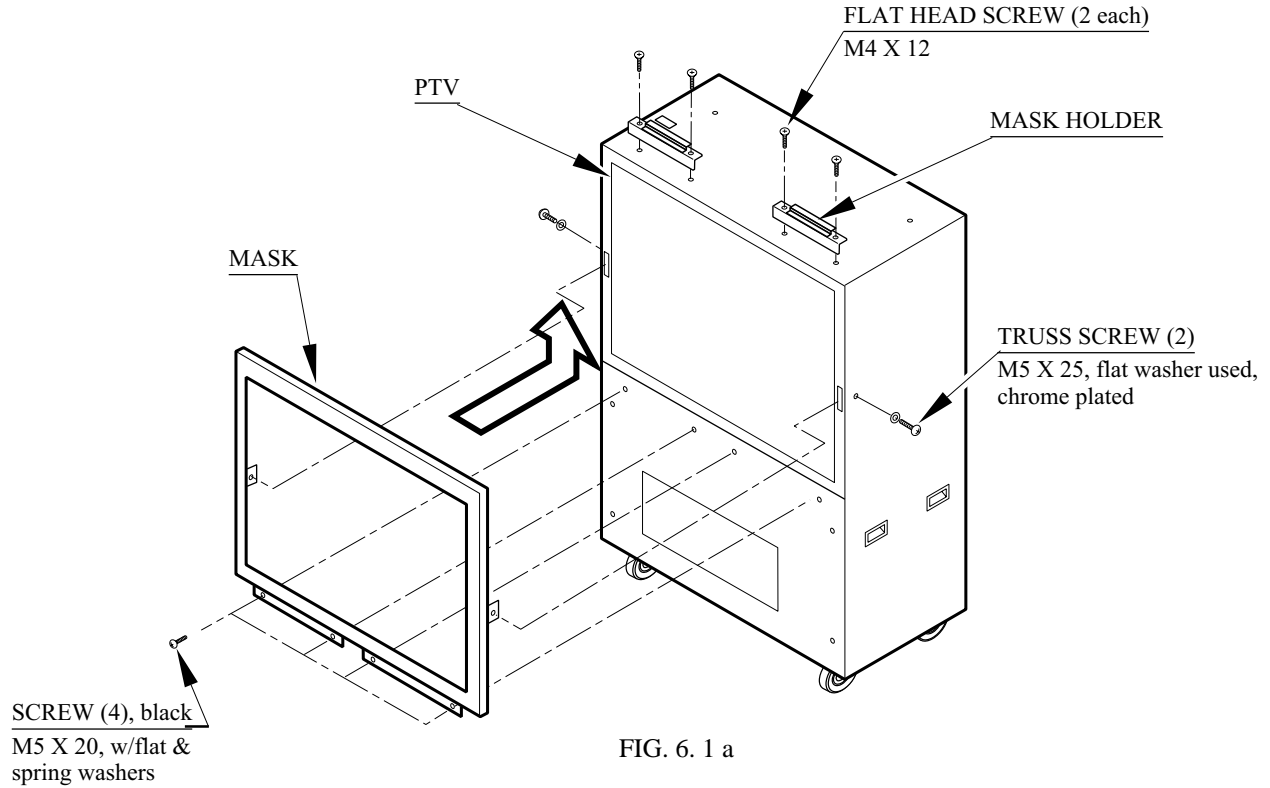
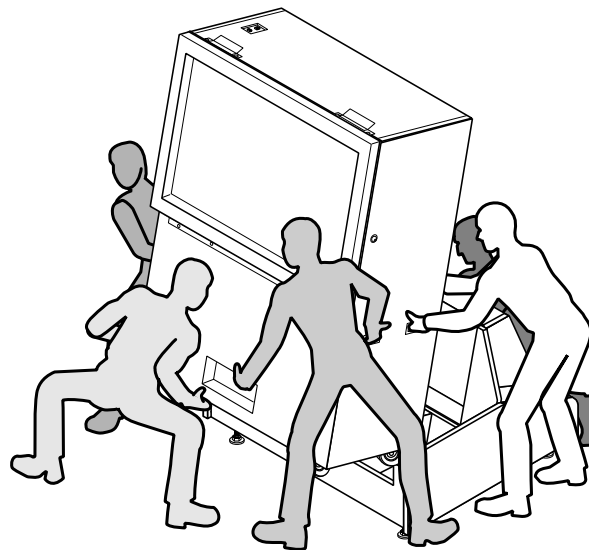

FIG. 6. 1 a

- ③ In order to prevent accidents during assembly work, have all of the Adjusters of the PTV Base make contact with the surfaces to secure the PTV Base.



For performing work, use 4 or more workers.

FIG. 6. 1 b

- ④ Mount the assembled PTV on the PTV Base. After mounting the PTV, move it to the rear part of the PTV Base. When performing this work, be sure to use 4 or more persons.
(FIG. 6. 1 b)
- ⑤ Install Panel Mount Bracket L and R to the front of the PTV by using 2 screws for each of them.

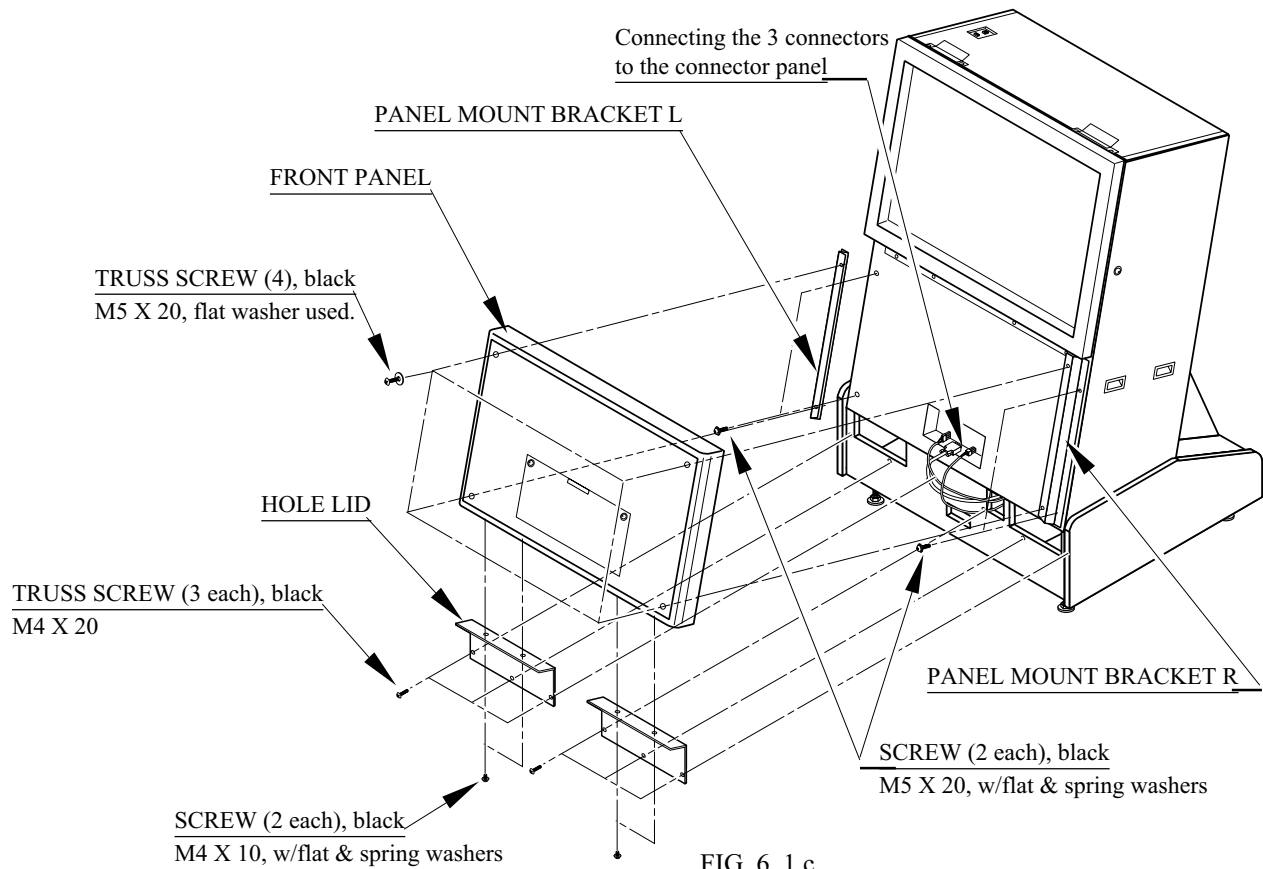

- ⑥ Connect the 3 connectors (2 for power supply, 1 for video signal) of the wires already connected to the PTV Base, to the 3 connectors on the PTV connector panel. The connectors can be inserted only in the fixed orientation. If you attempt to apply constrained force when inserting the connector, it may break. Fully make sure that it is in the correct orientation. The reflection signal connector has the securing screws at the both ends. After connecting, fasten the screws tightly.

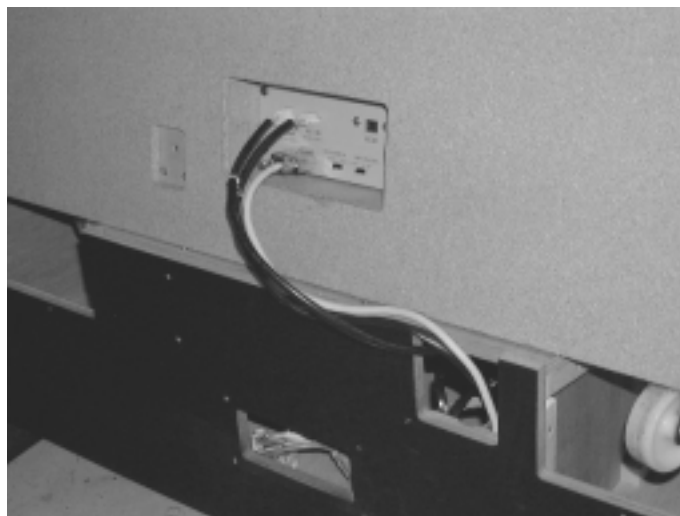
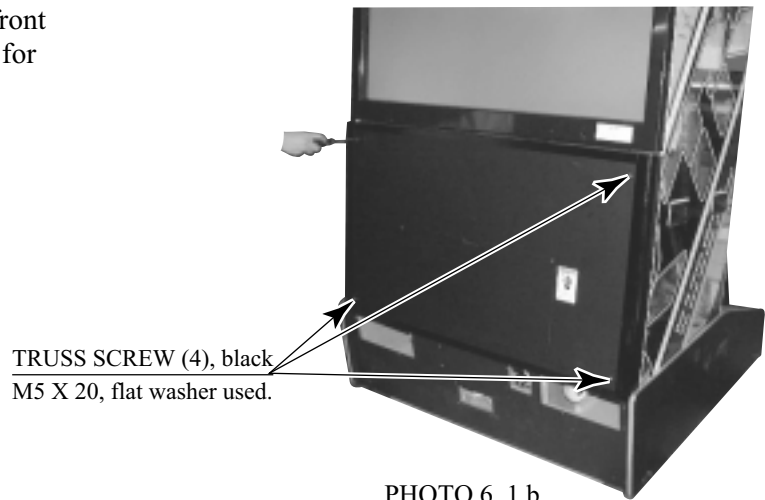
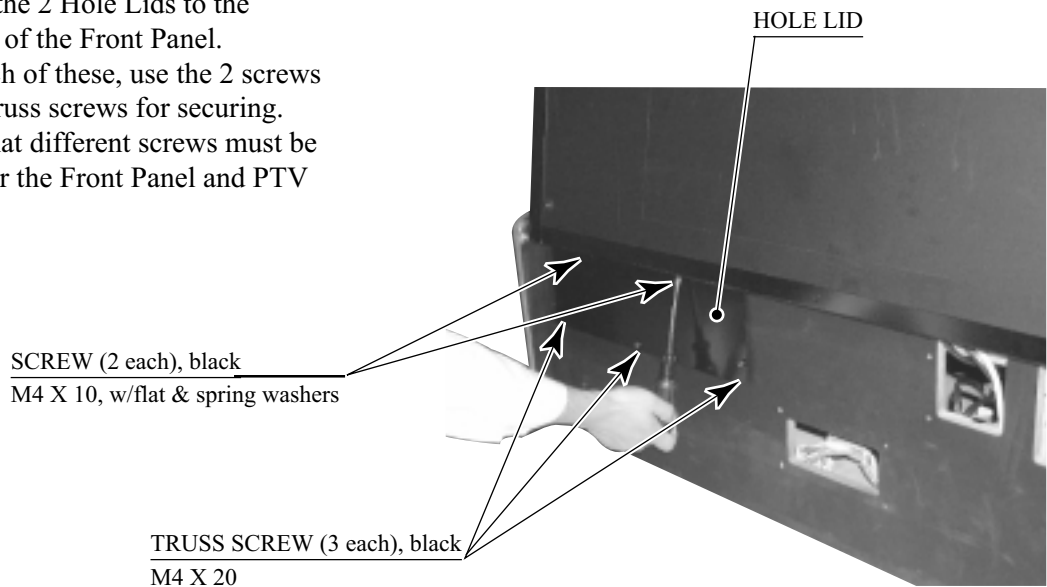

PHOTO 6. 1 a

- ⑦ Install the Front Panel to the front of PTV. Use the 4 truss screws for securing.



- ⑧ Install the 2 Hole Lids to the bottom of the Front Panel. For each of these, use the 2 screws and 3 truss screws for securing. Note that different screws must be used for the Front Panel and PTV Base.



- ⑨ This work must be performed by two persons:
Place the Billboard on the PTV top board.
- ⑩ With the Billboard shifted toward the PTV Screen, insert the base plate of the Billboard into the 2 mask holders of the PTV Top Board.
- ⑪ Use a step for the following works:
Using the 2 truss screws, secure the Billboard to the PTV Top Board.
- ⑫ Remove the 2 truss screws. Then, remove the Hole Lid from the Billboard.
- ⑬ Connect the 2 connectors in the Billboard to the 2 connectors on the PTV top board. The connectors can be inserted only in the fixed orientation. If you attempt to apply constrained force when inserting the connector, it may break. Fully make sure that it is in the correct orientation.
- ⑭ Reinstall the Hole Lid to the initial position by securing it with the 2 truss screws.

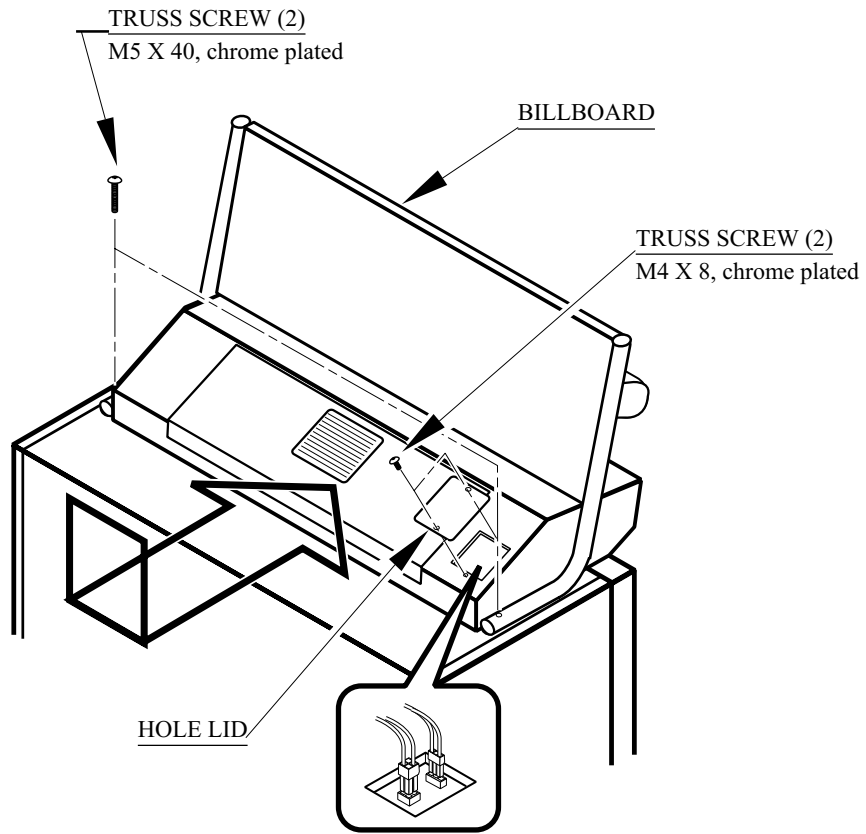

Connect the 2 Connectors.

FIG. 6. 1 d



For performing work, use 2 workers.

FIG. 6. 1 e

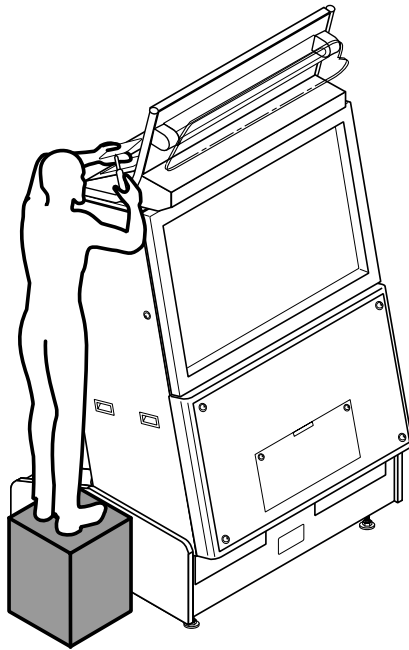

When performing work,
be sure to use a step.

FIG. 6. 1 f

2

WIRING CONNECTIONS BETWEEN THE CABINETS

With the ASSY Tube installed to the Front and Rear Cabinets, perform the cabinet-to-cabinet wiring. The connectors can be inserted only into those with the same number of pins, respectively, and can be inserted only in the fixed orientation. If you attempt to apply constrained force when inserting the connector, the connector or wiring may be damaged. Fully make sure that it is in the correct orientation.

- ① Draw out the 6 wiring connectors and the earth wire from the Front Cabinet.
- ② Connect the connector of the ASSY Tube and that of the Front Cabinet. Connect the connectors to those with the same number of pins, respectively.

Connect the Connector.



PHOTO 6. 2 a

- ③ The plate of the ASSY Tube has a stud used to secure the earth wire. Let the earth wire round terminal, flat washer, and spring washer pass through the stud in order. Then tighten the hexagon nut.

HEXAGON NUT (1)
M4, flat & spring washers used.



PHOTO 6. 2 b

- ④ Install the plate of the ASSY Tube to the front of the Front Cabinet by using the 4 truss screws. Do not pinch the wiring at this time.

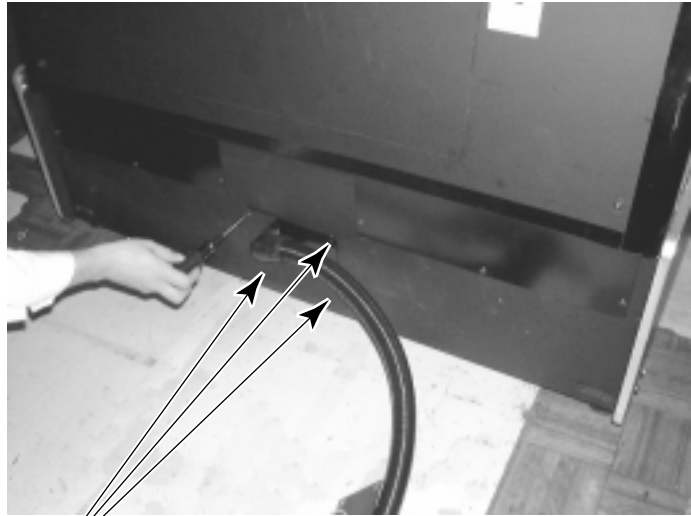

TRUSS SCREW (4), black
M4 X 20

PHOTO 6. 2 c

- ⑤ Locate the Front and Rear Cabinets close to each other. If you jerk the wiring by applying constrained force (in order to connect the connectors), the wiring may be damaged.
- ⑥ Draw out the 6 wiring connectors from the Rear Cabinet.

- ⑦ Connect the connector of the ASSY Tube and that of the Rear Cabinet. Connect the connectors to those with the same number of pins, respectively.



Connect the Connector.

PHOTO 6. 2 d

- ⑧ Install the plate of the ASSY Tube to the Rear Cabinet. Use the 4 screws for securing. Be careful not to pinch the wiring.



SCREW (4), black
M4 X 10, w/flat & spring washers

PHOTO 6. 2 e



Make sure that all of the adjusters are in contact with the floor. If they are not, the cabinet can move and cause an accident.

This machine has 8 casters (4 for the Front Cabinet, 4 for the Rear Cabinet) and 8 adjusters (4 for the Front Cabinet, 4 for the Rear Cabinet). (FIG. 6. 3 a) When the installation position is determined, cause the adjusters to come into contact with the floor directly, make adjustments in a manner so that the casters will be raised approximately 5mm. from the floor and make sure that the machine position is level.

- ① Move the machine to the installation position.
To ensure the safe operation of the product, provide sufficient space by adequately keeping the product away from wall surfaces and other cabinets.
- ② Cause all of the adjusters to make contact with the floor. By using a wrench, make adjustments in the height of the adjusters to ensure that the machine's position is level.
- ③ After making adjustments, fasten the adjuster nut upward and secure the height of the adjuster. (FIG. 6. 3 b)

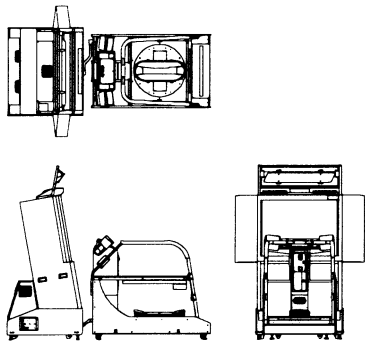
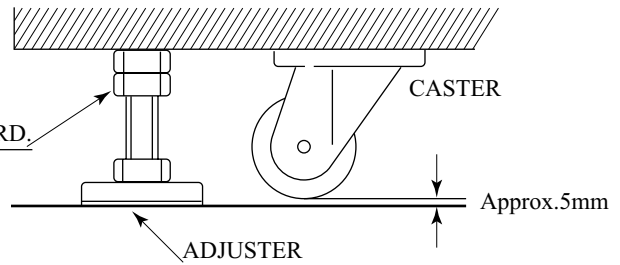
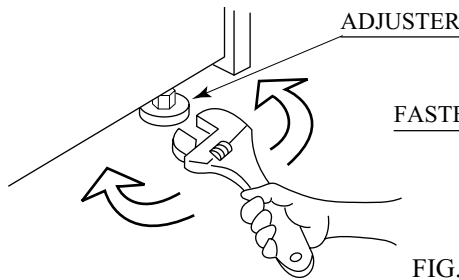
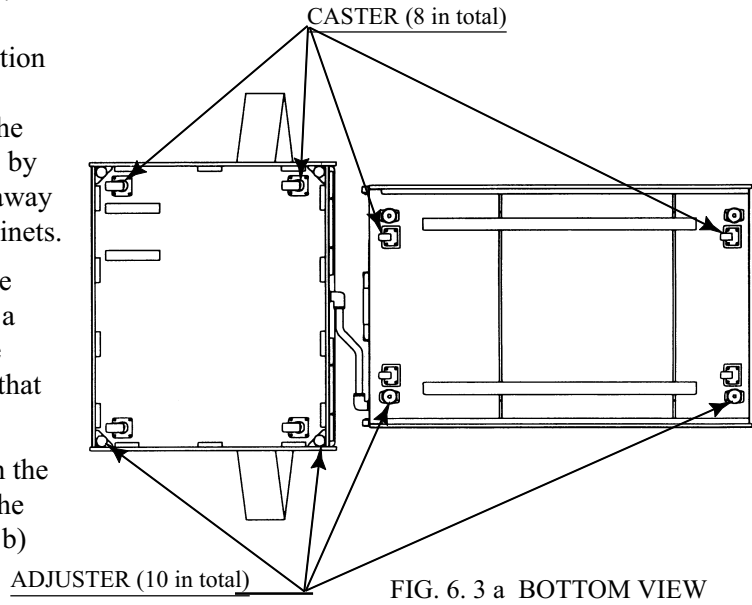

FIG. 6. 3 c
Refer to this Fig. (Scale:1/100) for the layout of the place of installation.

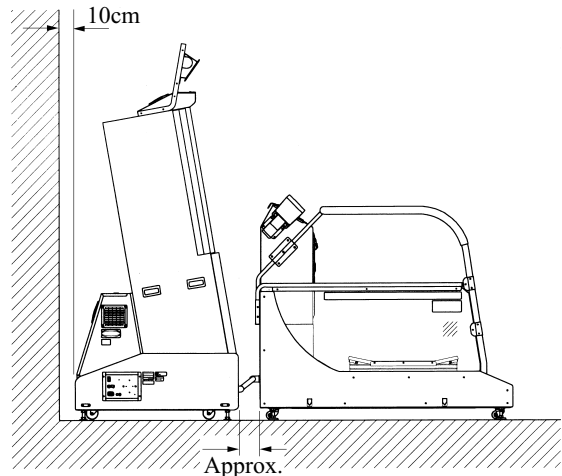
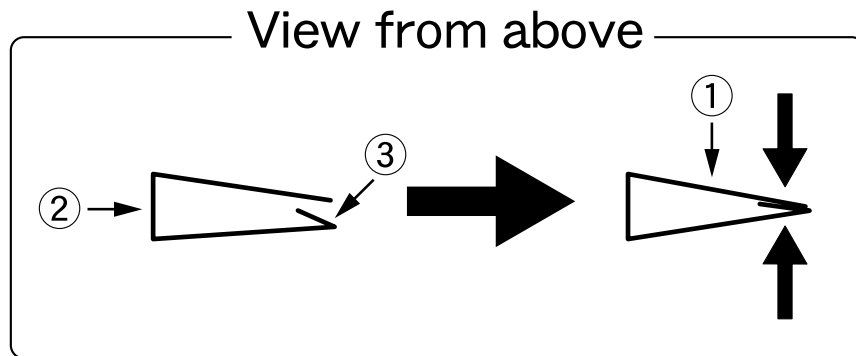
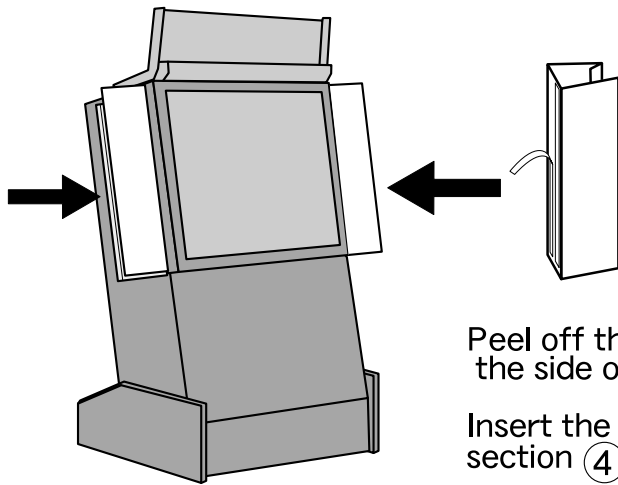
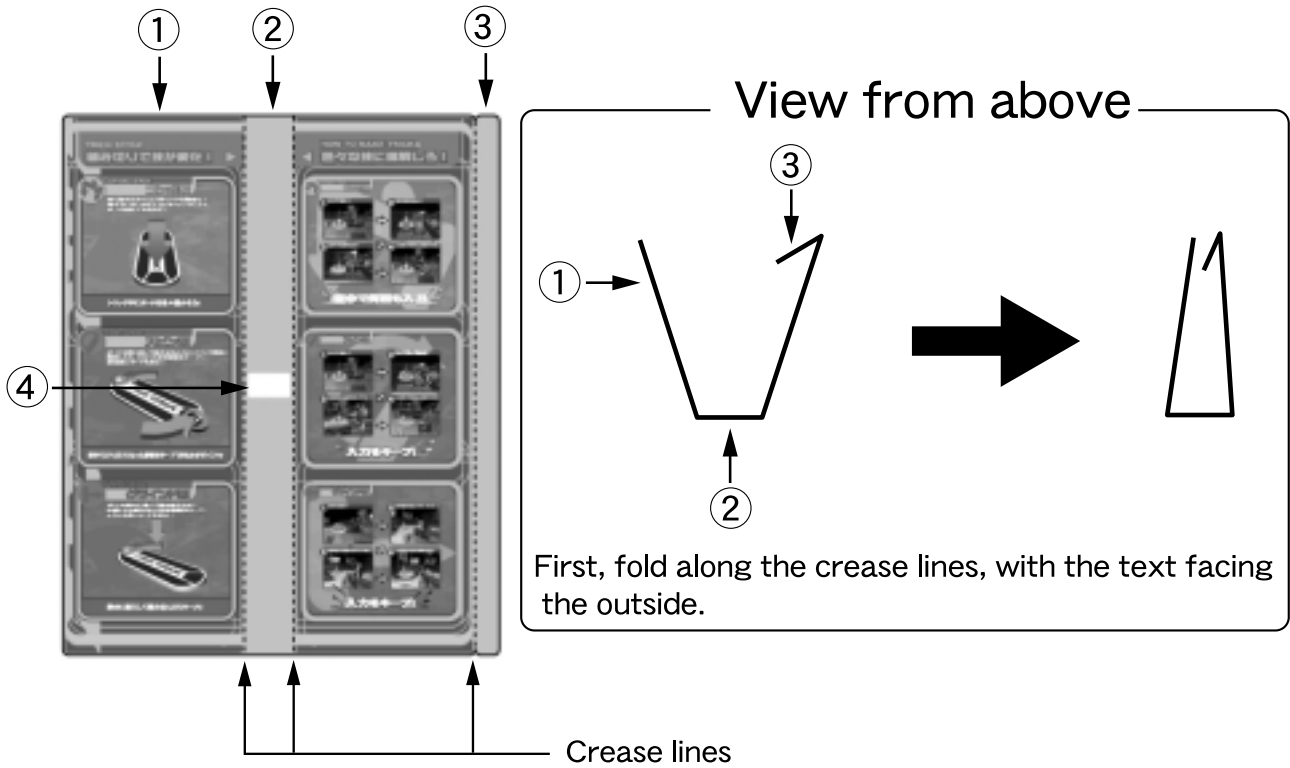

FIG. 6. 3 d
Provide sufficient space so as to allow for ventilation by the ventilation fan.
Provide space approximately 14cm. between the Front Cabinet and the Rear Cabinet.

4

INSTALLING THE SIDE POP



Peel off the tape on section ③, then affix it to the blank side of section ①.

FIG. 6. 4

5

POWER SUPPLY, AND EARTH CONNECTION



- Be sure to independently use the power supply socket outlet equipped with an Earth Leakage Breaker. Using a power supply without an Earth Leakage Breaker can cause a fire when electric leakage occurs.
- Ensure that the "accurately grounded indoor earth terminal" and the earth wire cable are available (except in the case where a power cord plug with earth is used). This product is equipped with the earth terminal. Connect the earth terminal and the indoor earth terminal with the prepared cable. If the grounding work is not performed appropriately, customers can be subjected to an electric shock, and the product's functioning may not be stable.
- Ensure that the power cord and earth wire are not exposed on the surface (passage, etc.). If exposed, they can be caught and are susceptible to damage. If damaged, the cord and wire can cause electric shock and short circuit accidents. Ensure that the wiring position is not in the customer's passage way or the wiring has protective covering.
- After wiring power cord on the floor, be sure to protect the power cord. Exposed power cord is susceptible to damage and causes an electric shock accident.

The AC Unit is mounted on the side of the machine. The AC Unit has Main SW, Circuit Protector and the Inlet which connects the Power Cord.

① Ensure that the Main SW is OFF.

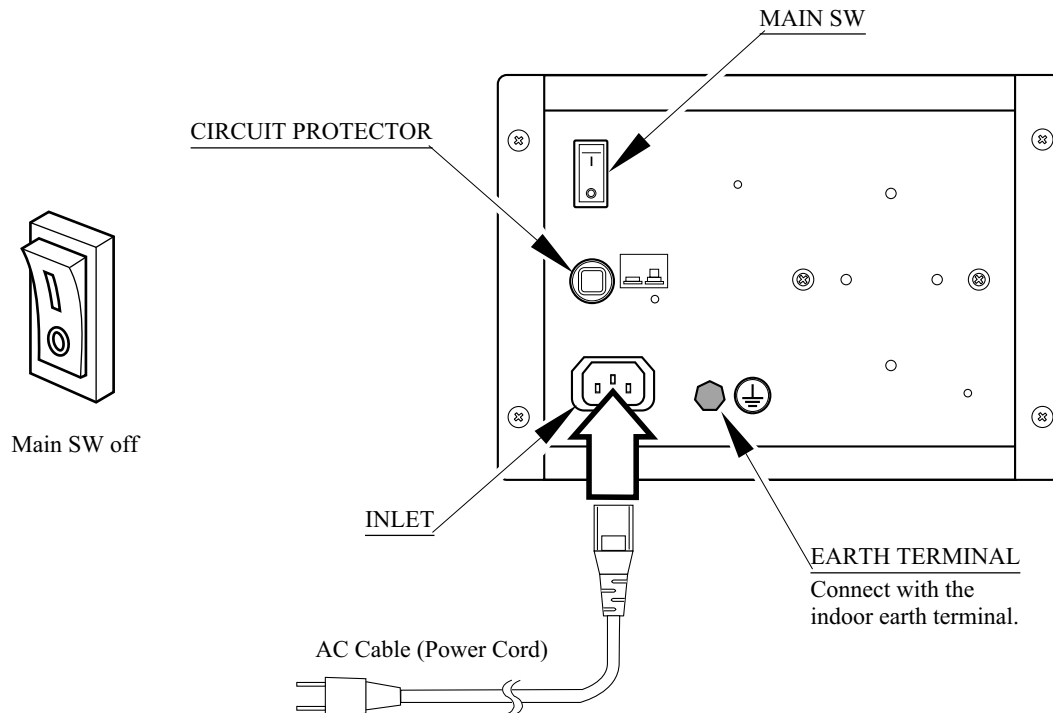
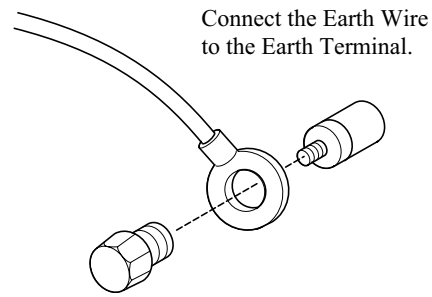

FIG. 6. 5 a AC unit

- ② Connect one end of the earth wire to the AC Unit earth terminal, and the other end to the indoor earth terminal. The AC Unit earth terminal has a Bolt and Nut combination. Take off the Nut, pass the end of earth wire through the Bolt, and fasten the Nut. Note that the Earth Wire is incorporated in the Power Cord for the Areas of AC 120V (USA) and AC 220 ~ 240V, and therefore, this procedure is not necessary.



Connect the Earth Wire to the Earth Terminal.

FIG. 6. 5 b Earth Wire Connection

- ③ Firmly insert the power plug into the socket outlet. Insert the opposite side of Power Cord plug to the AC Unit's connector ("INLET").
- ④ Perform wiring for the Power Cord and Earth Wire. Install protective covering for the Power Cord and Earth Wire.

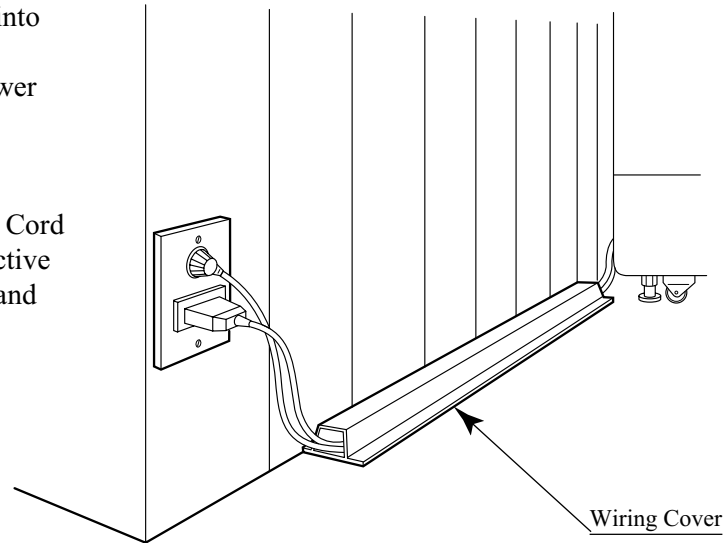
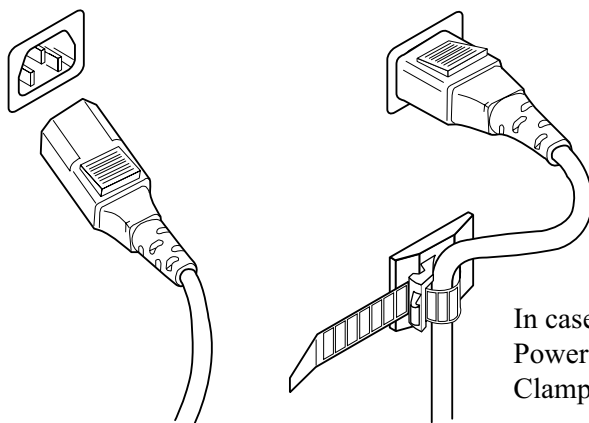

FIG. 6. 5 c Connecting Power Cord and Earth Wire



In case the Power Plug is apt to come out of place, secure the Power Cord to the periphery of the AC Unit with the Cord Clamp (an accessory).

HOW TO USE THE CORD CLAMP

6

TURNING POWER ON

Turn on the AC unit main switch to power on the machine. Once it is powered on, the Billboard fluorescent lamp and Slim Tube light up. After several seconds, the screen changes to the Advertise Screen, which is in the wait-for-guest mode. At the same time, the loudspeakers to the left and right of the Switch Panel and the super woofer located at the bottom of the cache box door output voices. If No Voice Output has been set, no voices are output during the Advertise Mode.

The four Cold-Cathode Tubes to the left and right of the Rear Cabinet light up or go out, depending on the status on the Advertise Screen.

Even after being powered off, this product retains data about the number of credits and ranking. It does not retain the Fractional Number of Coins (i.e., the number of coins put into the slot does not reach one credit) or Bonus Adder Count data. Thus, if you power on the machine after powering it off when the available number of credits for playing a game has remained, powering on machine causes the Start button to blink.

The Skateboard is unlocked when a game starts. Thus, it cannot be moved to the left or right unless a coin is put into the slot and the Start button is pressed.

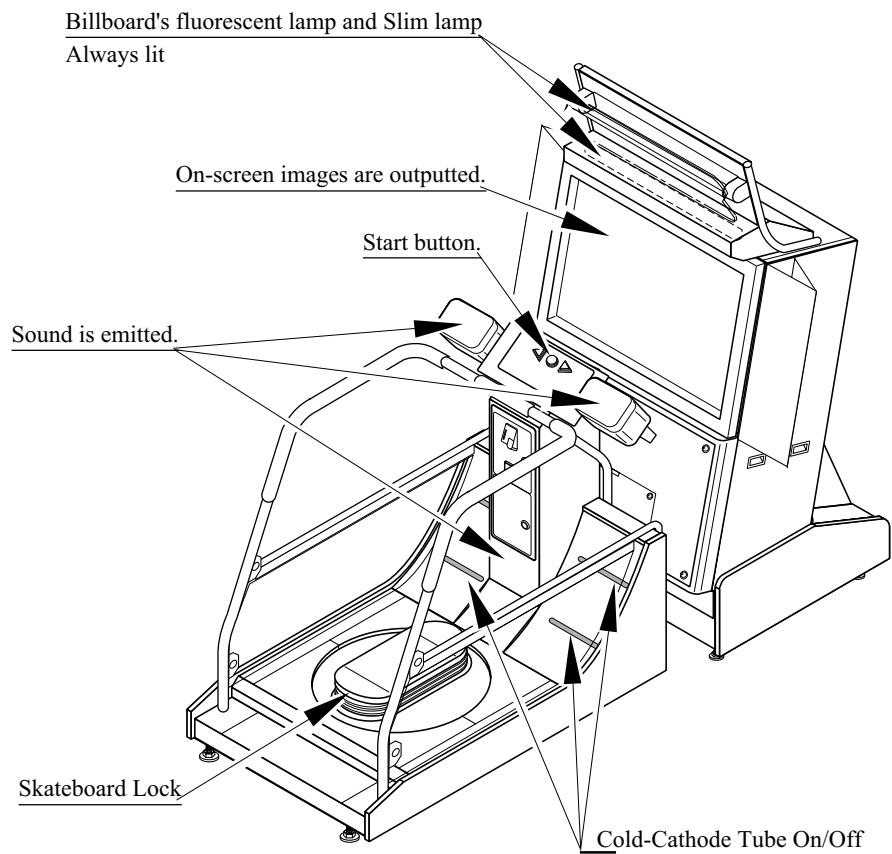

FIG. 6. 6



ASSEMBLING CHECK

In the TEST MODE, ensure that the assembly has been made correctly and IC BD. is satisfactory (refer to Section 9).

In the test mode, perform the following test:

(1) MEMORY TEST

```
RAM TEST

IC15 IC16 IC17S IC18S GOOD
IC22 IC23 IC24S IC25S GOOD
IC28 IC29S          GOOD
IC41                GOOD
IC42                GOOD
IC44 IC45S IC46 IC47S GOOD
IC91S IC92S         GOOD
IC98                GOOD

OPTIONAL SOUND BOARD:
IC2                GOOD

PRESS TEST BUTTON TO EXIT
```

Selecting the RAM TEST on the System Test Mode menu screen causes the on-board memory to be tested automatically. The game board is satisfactory if the display beside each IC No. shows GOOD.

(2) SOUND TEST

```
SOUND TEST
MAIN SPEAKER LEFT
MAIN SPEAKER RIGHT
> EXIT

SELECT WITH SERVICE BUTTON
AND
PRESS TEST BUTTON
```

On the Menu screen in the System Test Mode, selecting SOUND TEST causes the screen (on which sound related BD and wiring connections are tested) to be displayed. Be sure to check if the sound is satisfactorily emitted from each speaker and the sound volume is appropriate.

(3) C.R.T. TEST

In the System Test Mode menu, selecting C.R.T. TEST allows the screen (on which the projector is tested) to be displayed. Although the projector adjustments have been made at the time of shipment from the factory, make judgment as to whether an adjustment is needed by watching the test mode screen. If it is necessary, adjust the projector by referring to Section 11.

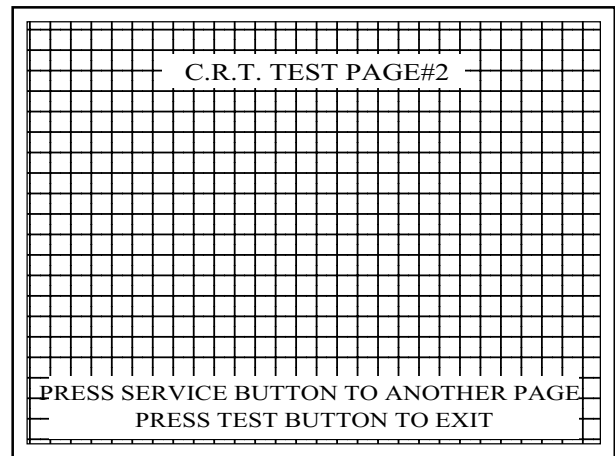
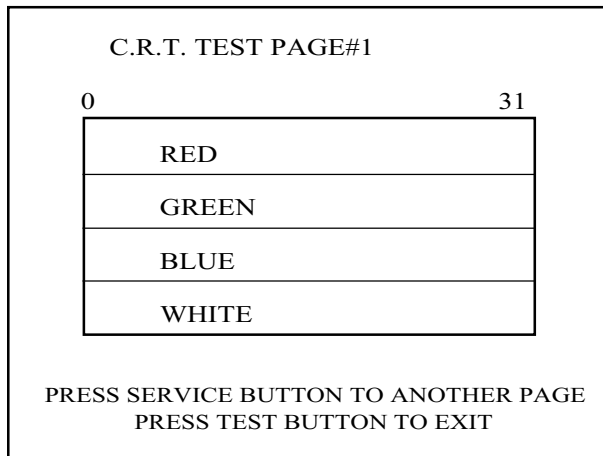

(4) INPUT TEST

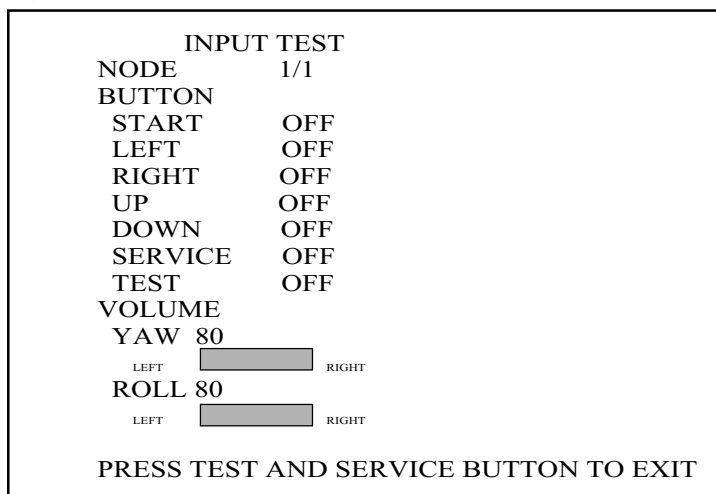

Selecting the INPUT TEST on the Game Test Mode menu screen causes the screen (on which each switch is tested) to be displayed. Press each switch. If the display beside each switch indicates "ON," the switch and wiring connections are satisfactory.

(5) OUTPUT TEST

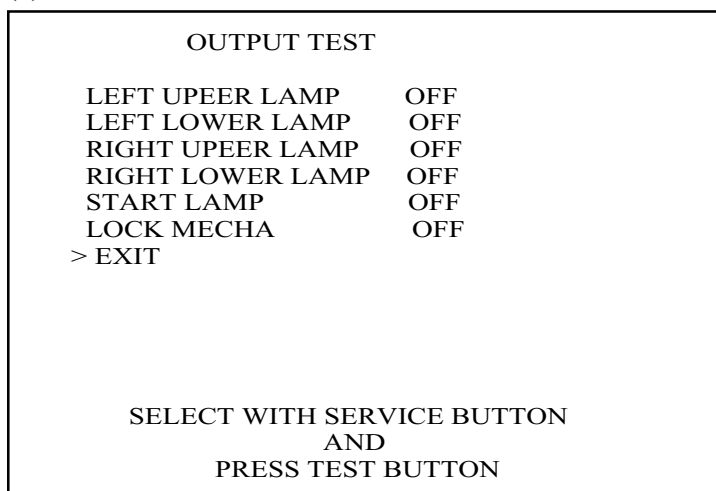

The OUTPUT Test menu screen in the Game Test Mode allows Lamps and wiring connections to be checked. Check if each lamp lights up satisfactorily.

Perform the above inspections also at the time of monthly inspections.

7. PRECAUTIONS TO BE HEEDED WHEN MOVING THE MACHINE



- When moving the machine, be sure to unplug the power plug. Moving the machine with the plug as is inserted can damage the power cord and cause fire and electric shock hazards.
- When moving the machine on the floor, retract the Adjusters and ensure that Casters make contact with the floor. During transportation, pay careful attention so that Casters do not tread power cords and earth wires. Damaging the power cords can cause electric shock and short circuit hazards.
- When lifting the cabinet, be sure to hold the grip portions or bottom part. Lifting the cabinet by holding other portions can damage parts and installation portions due to the empty weight of the cabinet, and cause personal injury.
- When transporting the product in places with step-like differences in grade, disassemble into each unit before transporting. Lifting up the product in an attempt to cross the step-like differences in an as is assembled condition may damage the unit's joining portions and cause a personal injury resulting from damage.
- When moving the PTV, do not push it from the rear side. Push it from sideways. Pushing the PTV from the rear side can have the PTV fall down, causing personal injury etc. In case the floor has slanted surfaces or step-like differences, be sure to move the machine by 2 or more persons.
- Do not insert the fork to places other than designated when using a Forklift to transport the machine.
Failure to observe this could cause falling down and injury resulting from falling down.



Do not push the plastic made parts. Failure to observe this may damage parts and cause injury due to fragments resulting from damage.



- When transporting the product in places with steps, disassemble into each unit before transporting. Inclining the product in an as is assembled condition or placing the cabinet in places with steps can damage the unit's joining portions.
- To protect surface, do not directly apply a rope to the surfaces of product. Use protective materials to the places the rope is applied to.

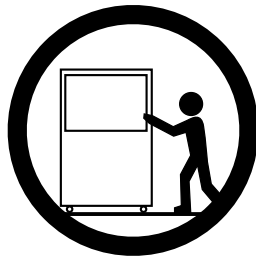

Do not push PTV from the back. Pushing the PTV from the back can cause the PTV to fall down. Push it from the side.

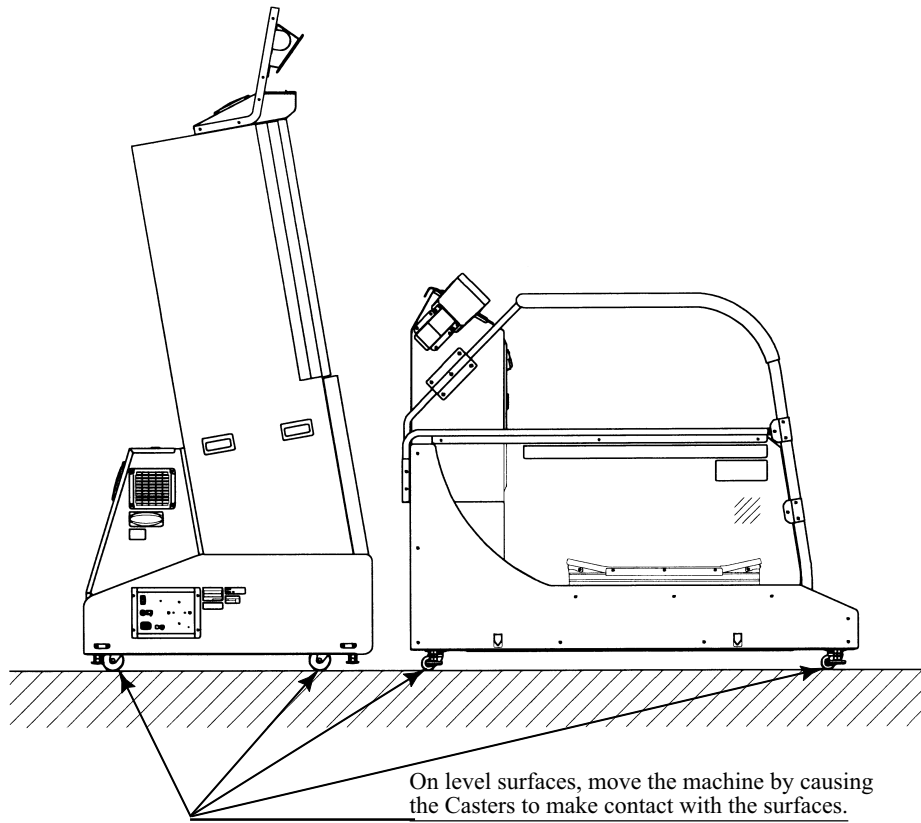

FIG. 7 a

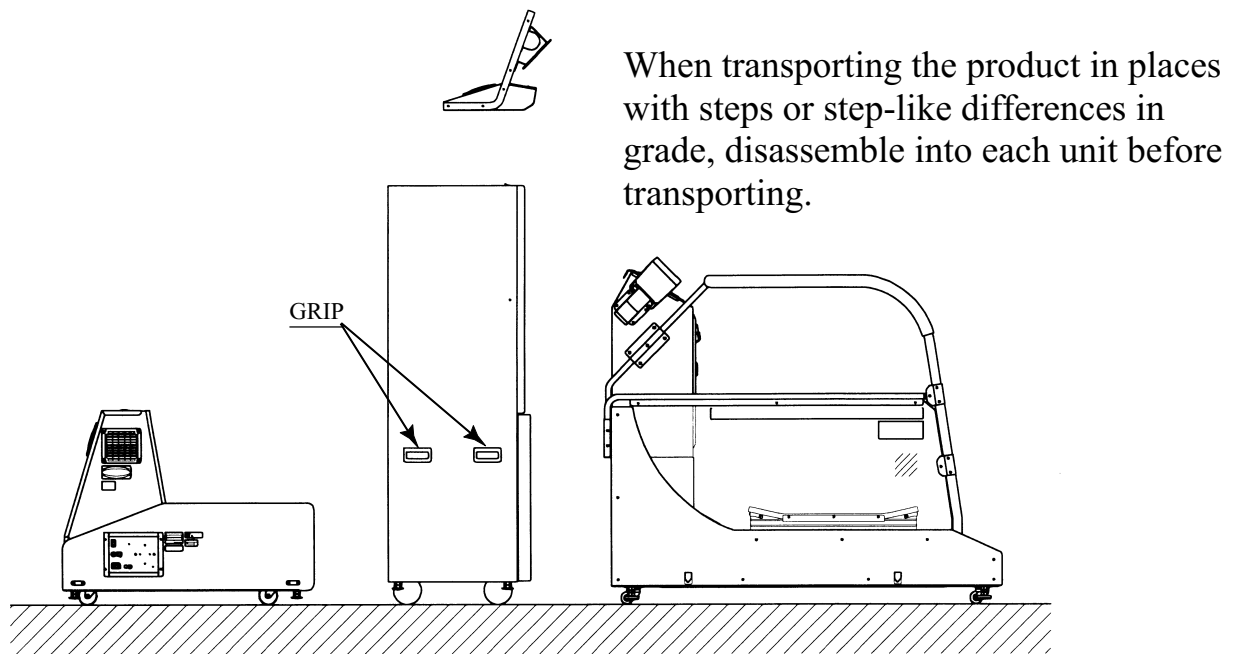

FIG. 7 b

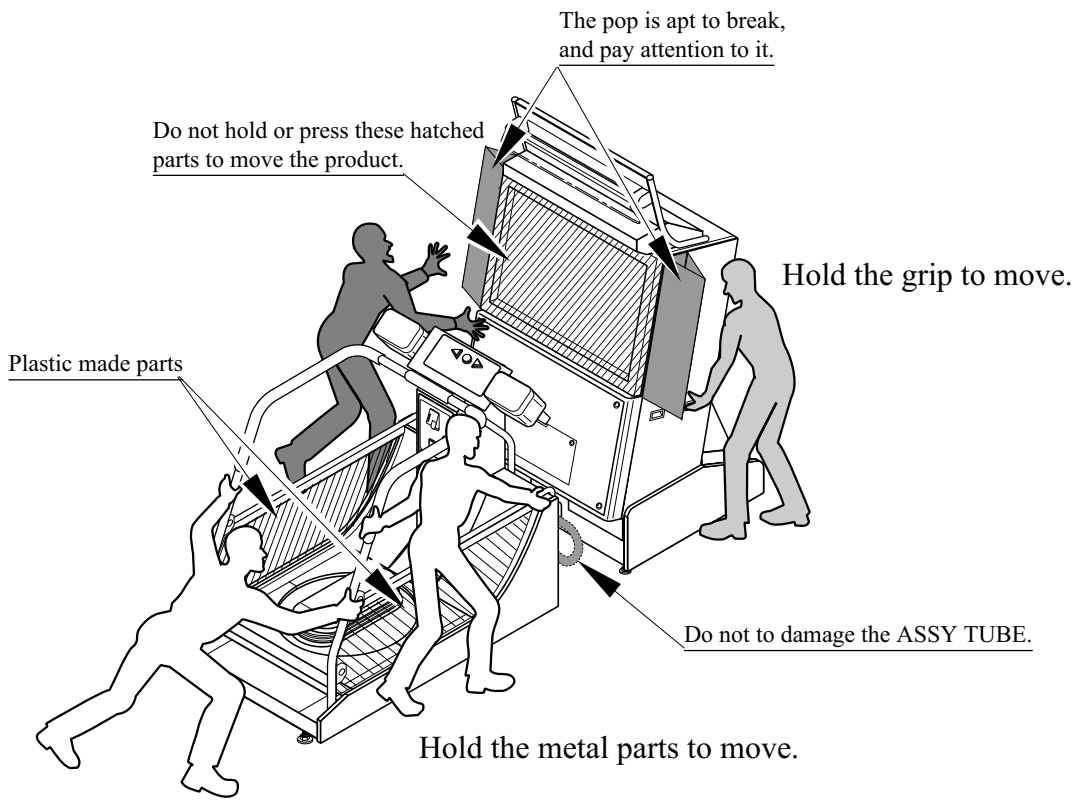

FIG. 7 c

8. CONTENTS OF GAME

The following explanations apply to the case the product is functioning satisfactorily. Should there be any moves different from the following contents, some sort of faults may have occurred. Immediately look into the cause of the fault and eliminate the cause thereof to ensure satisfactory operation.

While the machine is being energized, the Billboard's fluorescent lamp and Slim Tube continuously stay lit up.

The left and right Rear Cabinets light up or go out, depending on the status on the Advertise Screen.

The screen displays demonstration video images and ranking data.

The loudspeakers to the left and right of the Switch Panel and the super woofer located at the bottom of the cache box door output voices.

With the settings in the Test Mode, you can select whether to output voices in the Advertise Mode.

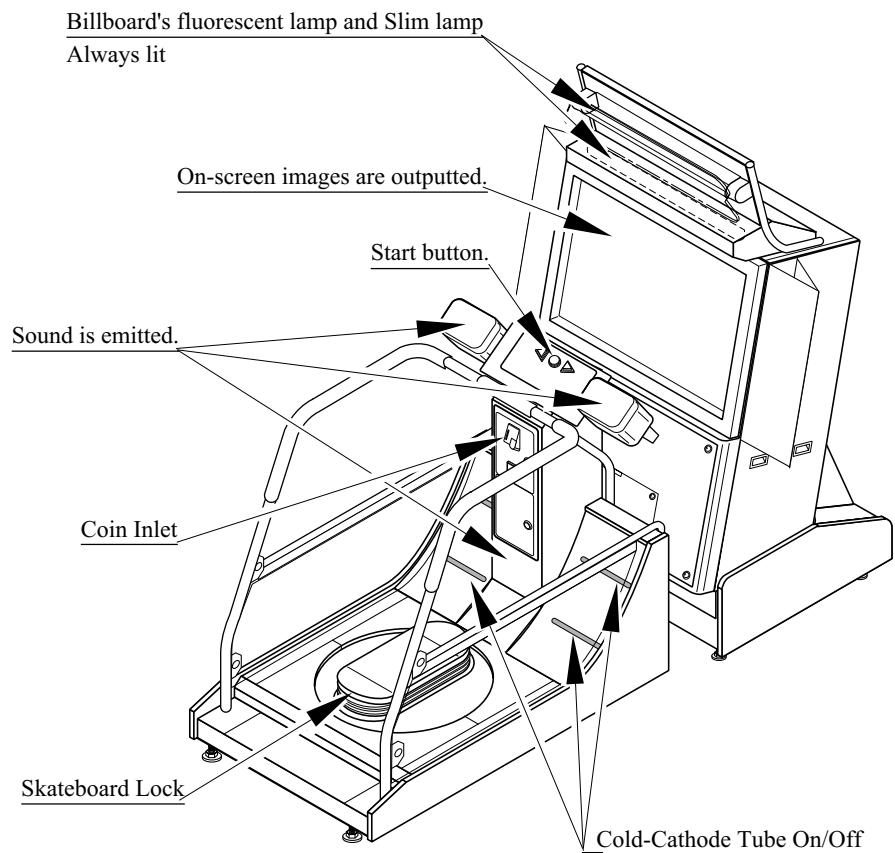

FIG. 8 b

The on-screen ADVERTISE before the commencement of game is comprised of the following:



FIG. 8 b



The Skateboard is unlocked before the game starts. Thus, it cannot be moved to the left or right unless a coin is put into the slot and the Start button is pressed.

How to Play

- ① Get on the Skateboard (i.e., Controller Board).
- ② The Coin Tower is located in the center of the enclosure. Once coins for one play session are put in the slot, the Start button lamp blinks. Pressing the Start button displays the Select Player Screen. Once it appears, credit display stops.
- ③ On the Select Player Screen, select the desired character for play. Using the Select button, select the desired one from the five characters. Then, determine it using the Start button. Select the character using the left and right Select buttons. Determine it using the Start button, located in the center. The numbers at the top right corner of the screen indicate the time limit for selection. The characters have both advantageous and disadvantageous characteristics about their running performance.
- ④ Once you determine the player, you are brought to the Select Stage Screen. Using the Select button, select the desired one from the three stages. Then, determine it using the Start button. There are two stage modes: Tutorial and Score Attack. One stage is available for the Tutorial Mode, and two stages are available for Score Attack Modes.
 - Tutorial Mode (left)
Lets the player learn three ways of triggering elementary tricks.
 - Score Attack Mode (center, right)
Allows the player to trigger tricks and compete for the number of coins acquired.

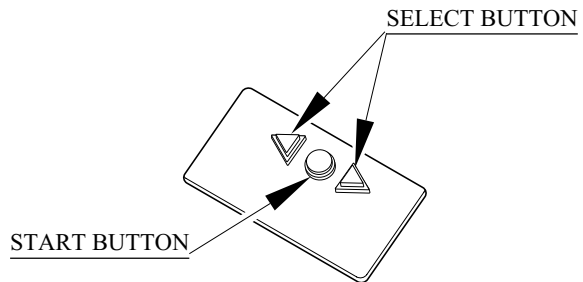

FIG. 8 c

- ⑤ While the Select Player or Stage Screen is on-screen, the remaining time for selection is displayed at the top right corner of the screen. If the player does not press the Start button within the time, the system will automatically regard the currently selected character and stage as the finally determined ones.



FIG. 8 d Player Select screen, Stage Select screen

- ⑥ Once the stage is determined, the game starts. After message "Release the lock of the controller board" appears, the Skateboard (i.e., Controller Board) is unlocked. Then, the player can perform Spin operations. At the bottom, turn in the desired direction in the manner of skateboarding. Further, the player can enjoy a sharper turn by spinning the board.

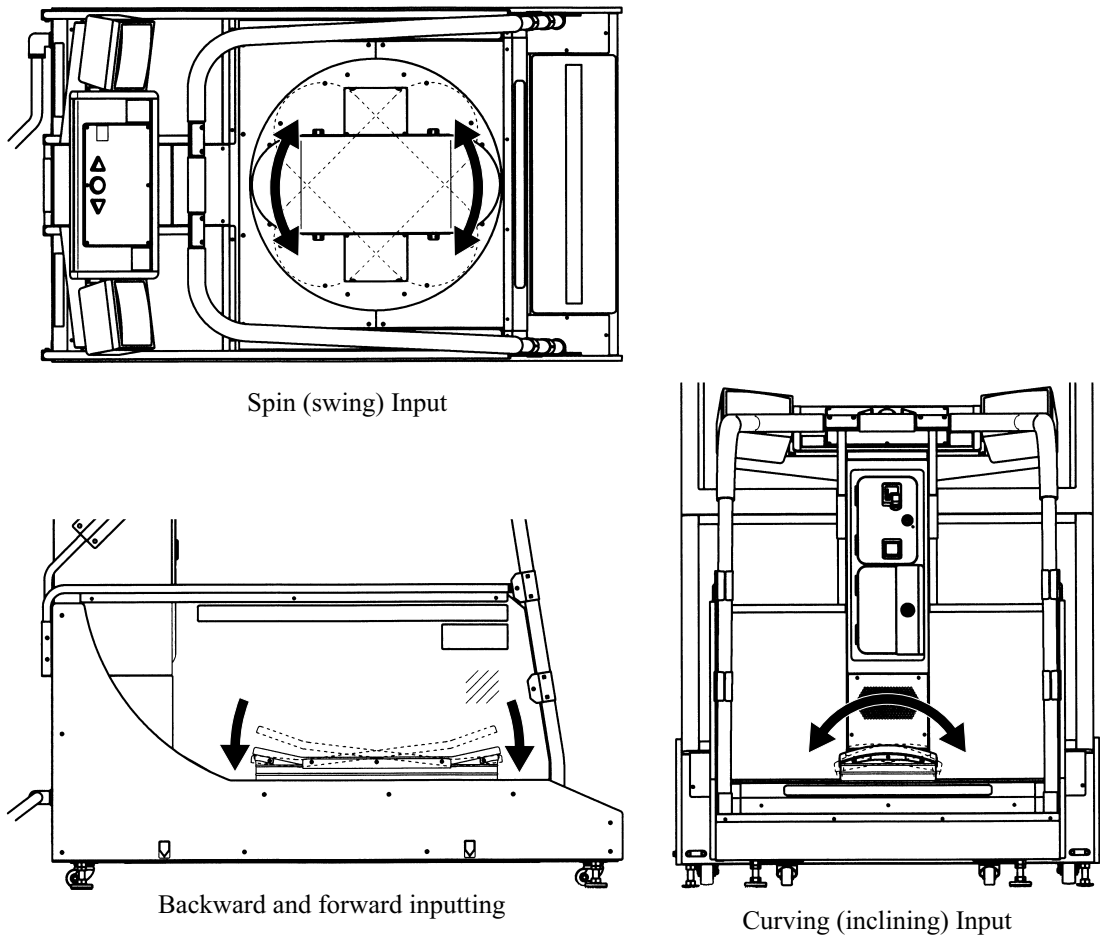

FIG. 8 e

At the bottom, turn in the desired direction in the manner of skateboarding.
Further, the player can enjoy a sharper turn by spinning the board.

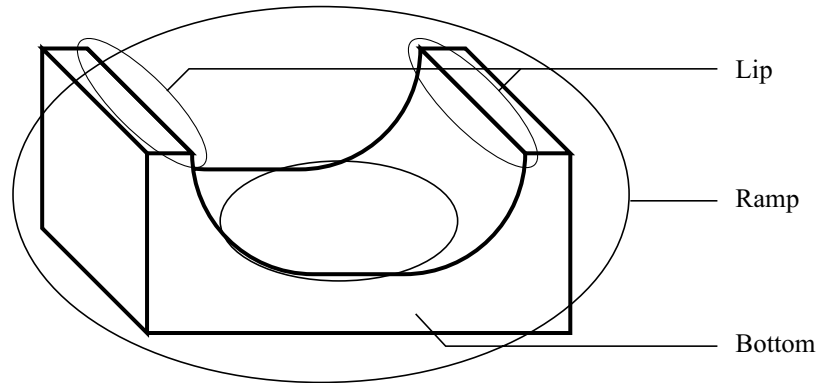

FIG. 8 f

- ⑦ The aim of this game is to get a high score by achieving a trick in the air.
The player can achieve a trick by inputting data to the Controller Board on the lip.

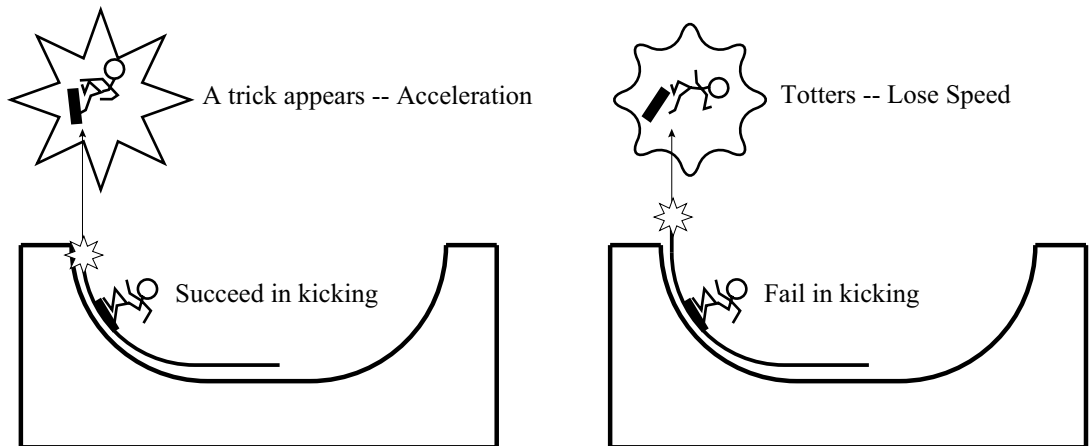

FIG. 8 g

In addition, the player can achieve tricks separately by inputting different types of data during kicking.

"Achieving a COMBO Trick"

The player can cause a COMBO trick by kicking on the back of the Controller Board at the front of the lip. Once the player can succeed in the kicking, he or she can link the tricks by reinputting the data in the air. The knack of acquiring proficiency is to input data moderately to the Controller Board, taking account into the his or her speed (i.e., duration of jump).

If the player inputs the first item of data after the jumping step is exceeded, the character loses its speed. The advice is displayed at this time.



FIG. 8 h

"How to Achieve a Spinning Trick"

The player can generate a spinning trick by spinning the Controller Board at the front of the lip. Once the player succeeds in the kicking, keeping the position achieved at the time of kicking in the air causes the character to start spinning. A longer time of spinning results in a higher score; however, if the player continues to keep the position at landing time, the character will fall down.

If the player inputs the first item of data after the jumping step is exceeded, the character loses its speed. The advice is displayed at this time.



FIG. 8 i

"Achieving a Grind Trick"

The player can generate a grind trick by diagonally entering the bottom and kicking on the front of the Controller Board at the front of the lip. Once the player succeeds in the kicking, keeping the position achieved at the time of kicking in the air causes the character to start skating on the lip. A longer time of skating results in a higher score; however, the character falls down unless the player restores the board before it totters.

If the player inputs the first item of data after the jumping step is exceeded, the character loses its speed. The advice is displayed at this time.



FIG. 8 j

⑧ The fields on the screen are as follows while the game is in progress:

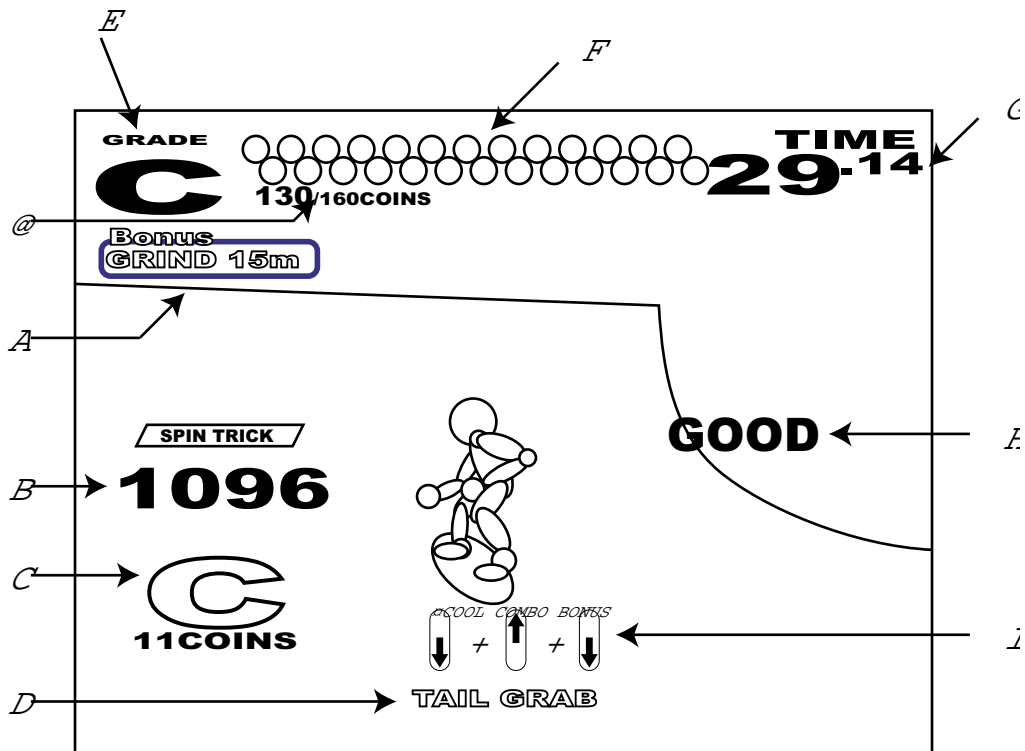

FIG. 8 k

1: Number of Coins Acquired

Displays the current number of coins acquired, and the number of coins that must be acquired until the next grade.

2: Bonus Title

The bonus coins can be acquired by clearing the contents of the title while a play is in progress. The contents vary each time the character grades up.

3: Trick

Displays the category and the contents of the currently achieved trick.

4: Evaluation per Jump

Displays the grade that corresponds to the total number of coins acquired per jump by grade. This grade has no relation to that on the top left corner of the screen.

5: Trick Name

Displays the name of the sill achieved.

6: Grade

Displays the current grade, which will rise when coins will be acquired.

7: Coins Acquired

Displays the current number of coins acquired, and the number of coins that must be acquired until the next grade.

8: Remaining Time

Remaining time within the stage. When it reaches 0, the stage ends.

9: Evaluation of Kicking

Appears when the timing of kicking is good.

10: Cool COMBO Bonus

When COMBO tricks are in progress, this may appear if combined tricks are cool.

- ⑨ When the time expires, the game is over.
- ⑩ After the game ends, lock the Skateboard (i.e., Controller Board).
- ⑪ If the player establishes a high score, the final evaluation will be followed by a screen letting him or her enter the three initials. In response to the prompt, the player should select the characters while scrolling them with the Select button. Then, determine the characters one by one using the Start button. Once all the three are determined, the player should locate the cursor at END and press the Start button for determination.
- ⑫ In the Score Attack Mode, the password appears along with the Game Over display. Record this password. The player can be registered for the World Ranking by sending it to the home page of this game. Using the Start button, the player can skip this screen, which remains on-screen for several tens of seconds.
Home page address: <http://www.hitmaker.co.jp/AIRTRIX>
By making the settings in the Test Mode, you can select whether to display the password.

9. EXPLANATION OF TEST AND DATA DISPLAY

By operating the switch unit, periodically perform the tests and data check. When installing the machine initially or collecting cash, or when the machine does not function correctly, perform checking in accordance with the explanations given in this section.

The following shows tests and modes that should be utilized as applicable.

SEGA HIKARU GAME BOARD is used for the product. The system of this game board allows another game to be played by replacing the ROM Board Case mounted on the SEGA HIKARU CASE. As such, the Test Mode of this system consists of the System Test Mode for the system to execute SELF-TEST, COIN ASSIGNMENTS, etc. used in common for the machines employing the SEGA HIKARU BOARD, and the Game Test Mode for the specific product to execute Input/Output test for the operation equipment, difficulty setting, etc.



IMPORTANT

- The contents of settings changed in the TEST mode are stored when the test mode is finished from EXIT in the menu mode. If the power is turned off before the TEST mode is finished, the contents of setting change become ineffective.
- Executing "BACKUP DATA CLEAR" in the SYSTEM TEST MODE does not clear the BOOKKEEPING data in the GAME TEST mode.
- Entering the TEST mode clears fractional number of coins less than one credit and BONUS ADDER data.

TABLE 9 EXPLANATION OF TEST MODE

ITEMS	DESCRIPTION	REFERENCE SECTIONS
INSTALLATION OF MACHINE	When the machine is installed, perform the following: 1. Check to see that each setting is as per standard setting made at the time of shipment. 2. In the INPUT TEST mode, check such input devices as each SW, V.R., etc. 3. In the OUTPUT TEST mode, check such output devices as lamps, motors, etc. 4. In the SELF-TEST mode, check ICs on the IC Board.	9-2 F,G, 9-3 D 9-2 C, 9-3 B 9-3 C 9-2 B,J
MEMORY	Choose RAM TEST and ROMBD TEST in the MENU mode to allow the MEMORY test to be performed. In this test, PROGRAM RAMs, ROMs, and ICs on the IC Board are checked.	9-2 B,J
PERIODIC SERVICING	Periodically perform the following: 1. MEMORY TEST 2. Ascertain each setting. 3. In the INPUT TEST mode, test the CONTROL device 4. In the OUTPUT TEST mode, check such output devices as lamps, motors, etc.	9-2 B,J 9-2 F,G, 9-3 D 9-2 C, 9-3 B 9-3 C
CONTROL SYSTEM	1. In the INPUT TEST mode, check such input devices as each SW, V.R., etc. 2. Adjust or replace each SW and VR. 3. If the problem can not be solved yet, check the CONTROL's moves.	9-2 C, 9-3 B 9-3 F, 10
MONITOR	In the MONITOR ADJUSTMENT mode, check to see if the PROJECTOR adjustment is appropriately made.	9-2 E 12
IC BOARD	1. MEMORY TEST 2. In the SOUND TEST mode, check the sound related ROMs.	9-2 B,J 9-2 D
DATA CHECK	Check such data as game play time and histogram to adjust the difficulty level, etc.	9-2 H, 9-3 E

9 - 1 SWITCH UNIT AND COIN METER



Never touch places other than those specified. Touching places not specified can cause electric shock and short circuit hazards.



- Adjust to the optimum sound volume by considering the environmental requirements of the installation location.
- If the COIN METER and the game board are electrically disconnected, game play is not possible.

SWITCH UNIT

Open the coin chute door, and the switch unit shown will appear.
The functioning of each SW is as follows:

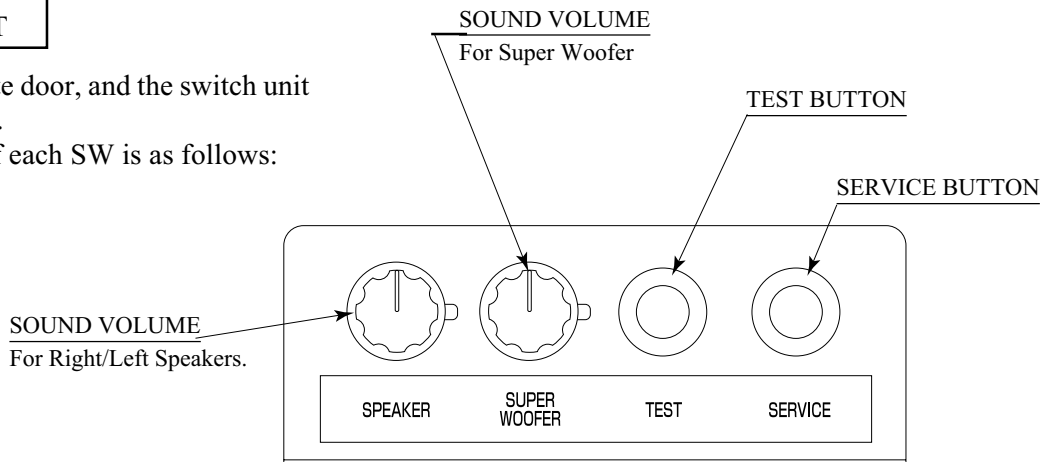

FIG. 9. 1 a SWITCH UNIT

SOUND VOLUME CONTROL :
SPEAKER

Adjusts the Right/Left Speakers.

SOUND VOLUME CONTROL :
SUPER WOOFER

Adjusts the Super Woofer .

TEST BUTTON :
TEST

For the handling of the test button, refer to the following pages.

SERVICE BUTTON :
SERVICE

Gives credits without registering on the coin meter.

COIN METER

Open the Cashbox Door by using the key to have the Coin Meter appear underneath the Cashbox.

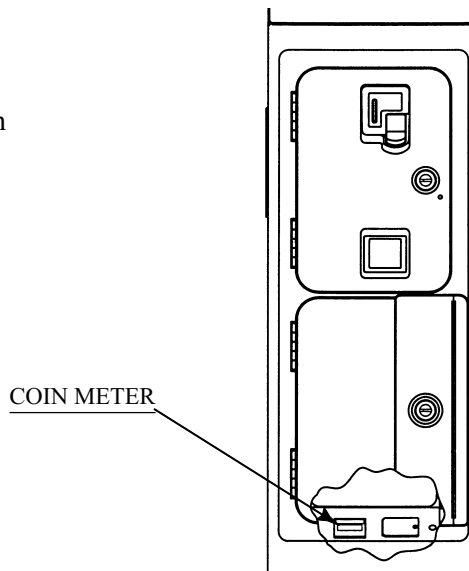

FIG. 9. 1 b

9 - 2 SYSTEM TEST MODE

A. SYSTEM TEST MODE MENU

Press TEST Button to enter the TEST MODE, and the following Menu screen will be displayed.

```
SYSTEM MENU
XXXXXXXXXX VERSION

RAM TEST
JVS TEST
SOUND TEST
C.R.T. TEST
SYSTEM ASSIGNMENTS
COIN ASSIGNMENTS
BOOKKEEPING
BACKUP DATA CLEAR
ROMBD TEST
CLOCK SETTING
GAME TEST MODE
> EXIT

SELECT WITH SERVICE BUTTON
AND
PRESS TEST BUTTON
```

- Press SERVICE Button to move the arrow (>) to the desired item and select with TEST Button.
- Bring the arrow to EXIT and press TEST Button to return to the GAME Mode.

B. RAM TEST

This allows for checking the functioning of the RAM on the Game BD. In this test, IC's are checked in every row. During the test, "CHECKING" is displayed at the right-hand side of the screen. "BAD" is indicated for irregular RAMs, if any. Upon finishing the test, "PRESS TEST BUTTON TO EXIT" is displayed on the lower center of the monitor. Press TEST Button to return to the MENU screen.

```
RAM TEST

IC15 IC16 IC17S IC18S GOOD
IC22 IC23 IC24S IC25S GOOD
IC28 IC29S          GOOD
IC41                  GOOD
IC42                  GOOD
IC44 IC45S IC46 IC47S GOOD
IC91S IC92S          GOOD
IC98                  GOOD

OPTIONAL SOUND BOARD:
IC2                  GOOD

PRESS TEST BUTTON TO EXIT
```

C. JVS TEST

```

      JVS TEST
      INPUT TEST
      > EXIT

NODE    1/1
NAME    SEGA ENTERPRISES,LTD.;I/O BD JVS;
        837-13551 ;Ver1.00;98/10
CMD VER  1.1
JVS VER  2.0
COM VER  1.0
SWITCH   2 PLAYERS 13BITS
COIN     2 SLOTS
ANALOG   8CH
DRIVER OUT 6CH

      SELECT WITH SERVICE BUTTON
      AND
      PRESS TEST BUTTON
```

In this test, Functioning of the I/O Board connected to Game Board is displayed and INPUT TEST can be performed. Execute EXIT to return to the MENU screen.

When INPUT TEST is selected and executed, the following screen appears.

```

      JVS TEST
      > DISPLAY CONFIG
      EXIT

NODE    1/1
SWITCH
  SYSTEM _____
  PLAYER1 _____
  PLAYER2 _____
COIN
  SLOT1 0000 SLOT2 8000
ANALOG
  CH1 6300 CH2 5A00 CH3 7D00 CH4 8100
  CH5 1F00 CH6 1D00 CH7 1F00 CH8 2000

      SELECT WITH SERVICE BUTTON
      AND
      PRESS TEST BUTTON
```

When INPUT is performed, the Switch value changes to 1 from _ . Execute EXIT to return to the MENU screen.

D. SOUND TEST

Sound Output can be performed and each Speaker can be checked.

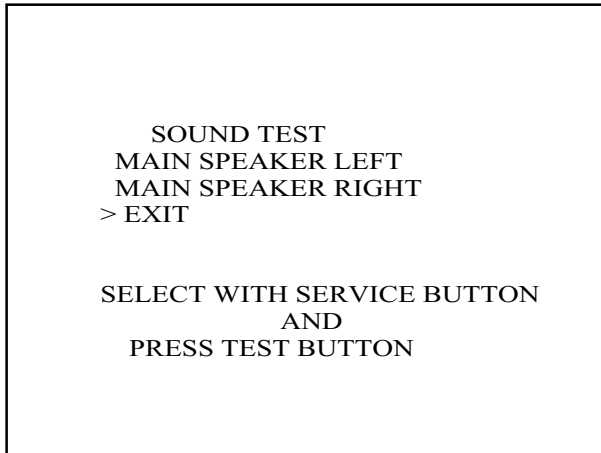

Select the desired item and press TEST Button, and sound is emitted from the corresponding Speaker. Execute EXIT to return to the MENU screen.

E. C.R.T. TEST

In this test, monitor adjustment can be performed. Periodically check to see if the monitor adjustment is appropriate in this test. This test consists of 2 screens. Use SERVICE Button to change the screen displayed. Press TEST Button to return to the MENU screen.

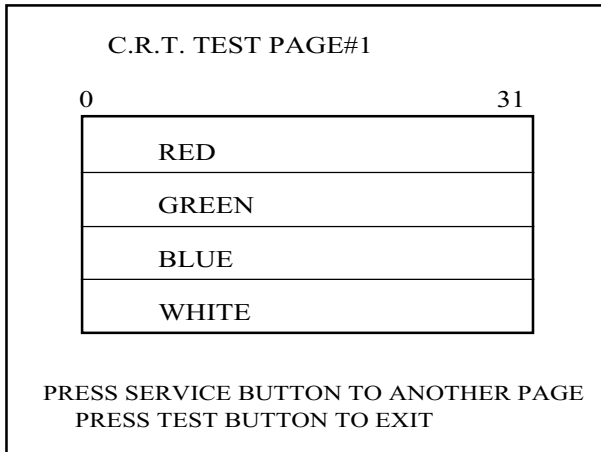

The first screen displays color bars. The color adjustment can be checked. Each of red, green, blue is the darkest at the leftmost end, and becomes brighter towards the right-hand end.

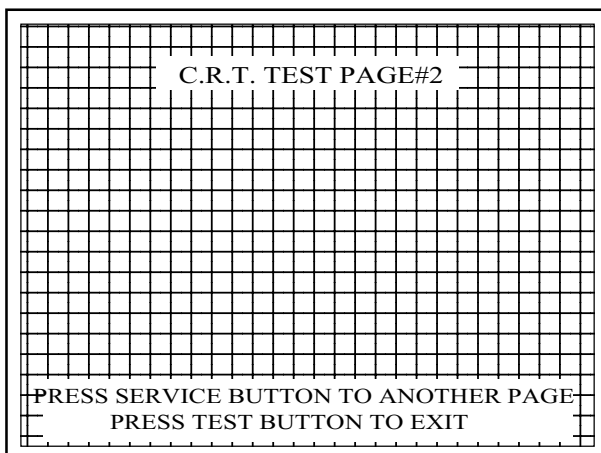

The second screen displays crosshatches. In this page, monitor size and deviation can be checked.

F. SYSTEM ASSIGNMENTS

The settings of cabinet and board can be changed. Set each item suitable to the connected cabinet. Use the setting as is the time of shipment except for ADVERTISE SOUND.

SYSTEM ASSIGNMENTS

CABINET TYPE 1PLAYER
ADVERTISE SOUND ON
MONITOR TYPE HORIZONTAL
DISPLAY MODE AUTOSCAN
SERVICE TYPE COMMON

> EXIT

SELECT WITH SERVICE BUTTON
AND
PRESS TEST BUTTON

- CABINET TYPE specifies Control Panel and number of Coin Chute. The number of Player displayed in BOOKKEEPING varies in accordance with the value here.
- ADVERTISE SOUND is used for settings of emitting sound during ADVERTISE.
- MONITOR TYPE sets the on-screen display to the positional direction of monitor (HORIZONTAL or VERTICAL). If set to VERTICAL, the on-screen display for the test mode is vertically positioned in accordance with the setting.
- DISPLAY MODE sets the monitor's display frequency. In this mode, if other than AUTOSCAN is selected and EXIT is executed, the display frequency is changed to the selected setting.
- SERVICE TYPE sets the functioning of when the Service Button is pressed, in case that several Service Buttons exist.
 - INDIVIDUAL
By pressing Service Button, Service credit can be obtained for the Player corresponding to the Service Button pressed.
 - COMMON
By pressing any Service Button, Service credit can be obtained for all Players.

G. COIN ASSIGNMENTS

In this mode, the setting of incremental credit increase as against coin insertion can be changed. This test consists of 3 screens, and the following is the first screen. The setting done in the first screen will be stored when exited.

```
COIN ASSIGNMENTS
COIN CHUTE TYPE      COMMON
COIN/CREDIT SETTING  #1
COIN CHUTE #1
  1COIN 1CREDIT

COIN CHUTE #2
  1COIN 1CREDIT

MANUAL SETTING
SEQUENCE SETTING
> EXIT

SELECT WITH SERVICE BUTTON
  AND
PRESS TEST BUTTON
```

- COIN CHUTE TYPE sets whether Coin Chute is used in common by all players or separately allocated to each player in case 2 or more Coin Chutes are incorporated.
COMMON: This setting is for common use by plural players.
INDIVIDUAL: As each player uses an independent coin chute, setting to INDIVIDUAL causes COIN CHUTE #2 to be disappeared.
- COIN/CREDIT SETTING is set when using one of the existing 26 settings or FREE PLAY. The selected coin rates in the COIN/CREDIT SETTING are displayed below COIN CHUTE #1 and COIN CHUTE #2. If you wish to set a coin rate rather than to select from the existing setting, select MANUAL SETTING. The display next to COIN/CREDIT SETTING indicates "MANUAL", not "#n" in this case.
- This game does not use SEQUENCE SETTING.
Do not change the SEQUENCE SETTING data.

○ MANUAL SETTING

When MANUAL SETTING is selected in the first screen, the following second screen appears.

COIN ASSIGNMENTS	
MANUAL SETTING	
COIN TO CREDIT	1
BONUS ADDER	0
COIN CHUTE #1 MULTIPLIER	
1 COINCOUNT AS 1COIN	
COIN	1 2 3 4 5 6 7 8 9
CREDIT	1 2 3 4 5 6 7 8 9
COIN CHUTE #2 MULTIPLIER	
1 COINCOUNT AS 1COIN	
COIN	1 2 3 4 5 6 7 8 9
CREDIT	1 2 3 4 5 6 7 8 9
SEQUENCE SETTING	
> EXIT	
SELECT WITH SERVICE BUTTON	
AND	
PRESS TEST BUTTON	

- COIN TO CREDIT determines how many coins are needed for one credit. (1 ~ 9)
- BONUS ADDER determines how many coins should be inserted to obtain one SERVICE COIN.
- COIN CHUTE #1 MULTIPLIER, COIN CHUTE #2 MULTIPLIER sets how many tokens one Coin represents inserted in each COIN CHUTE.

SETTING EXAMPLE 1)

Setting of 2 COINS 1 CREDIT, set to:

COIN TO CREDIT	:2
BONUS ADDER	:0
COIN CHUTE #1 MULTIPLIER	:1

SETTING EXAMPLE 2)

Setting of 5 COINS 6 CREDITS (5 COINS 1 BONUS), set to

COIN TO CREDIT	:1
BONUS ADDER	:5
COIN CHUTE #1 MULTIPLIER	:1

When exiting from MANUAL SETTING, if the identical coin rate is in the existing COIN/ CREDIT SETTING, such existing mode other than what is set in the MANUAL SETTING is confirmed.

TABLE 1 COIN/CREDIT SETTING

NAME OF SETTING	FUNCTIONING OF COIN CHUTE #1		FUNCTIONING OF COIN CHUTE #2	
SETTING #1	1 COIN	1 CREDIT	1 COIN	1 CREDIT
SETTING #2	1 COIN	2 CREDITS	1 COIN	1 CREDIT
SETTING #3	1 COIN	3 CREDITS	1 COIN	1 CREDIT
SETTING #4	1 COIN	4 CREDITS	1 COIN	1 CREDIT
SETTING #5	1 COIN	5 CREDITS	1 COIN	1 CREDIT
SETTING #6	1 COIN	2 CREDITS	1 COIN	2 CREDITS
SETTING #7	1 COIN	5 CREDITS	1 COIN	2 CREDITS
SETTING #8	1 COIN	3 CREDITS	1 COIN	3 CREDITS
SETTING #9	1 COIN	4 CREDITS	1 COIN	4 CREDITS
SETTING #10	1 COIN	5 CREDITS	1 COIN	5 CREDITS
SETTING #11	1 COIN	6 CREDITS	1 COIN	6 CREDITS
SETTING #12	2 COINS	1 CREDIT	2 COINS	1 CREDIT
SETTING #13	1 COIN	1 CREDIT	2 COINS	1 CREDIT
SETTING #14	1 COIN	2 CREDITS	2 COINS	1 CREDIT
SETTING #15	1 COIN	1 CREDIT	1 COIN	1 CREDIT
	2 COINS	3 CREDITS	2 COINS	3 CREDITS
SETTING #16	1 COIN	3 CREDITS	1 COIN	1 CREDIT
			2 COINS	3 CREDITS
SETTING #17	3 COINS	1 CREDIT	3 COINS	1 CREDIT
SETTING #18	4 COINS	1 CREDIT	4 COINS	1 CREDIT
SETTING #19	1 COIN	1 CREDIT	1 COIN	1 CREDIT
	2 COINS	2 CREDITS	2 COINS	2 CREDITS
	3 COINS	3 CREDITS	3 COINS	3 CREDITS
	4 COINS	5 CREDITS	4 COINS	5 CREDITS
SETTING #20	1 COIN	5 CREDITS	1 COIN	1 CREDIT
			2 COINS	2 CREDITS
			3 COINS	3 CREDITS
			4 COINS	5 CREDITS
SETTING #21	5 COINS	1 CREDIT	5 COINS	1 CREDIT
SETTING #22	1 COIN	2 CREDITS	3 COINS	1 CREDIT
			5 COINS	2 CREDITS
SETTING #23	2 COINS	1 CREDIT	2 COINS	1 CREDIT
	4 COINS	2 CREDITS	4 COINS	2 CREDITS
	5 COINS	3 CREDITS	5 COINS	3 CREDITS
SETTING #24	1 COIN	3 CREDITS	2 COINS	1 CREDIT
			4 COINS	2 CREDITS
			5 COINS	3 CREDITS
SETTING #25	1 COIN	1 CREDIT	1 COIN	1 CREDIT
	2 COINS	2 CREDITS	2 COINS	2 CREDITS
	3 COINS	3 CREDITS	3 COINS	3 CREDITS
	4 COINS	4 CREDITS	4 COINS	4 CREDITS
	5 COINS	6 CREDITS	5 COINS	6 CREDITS
SETTING #26	1 COIN	6 CREDITS	1 COIN	1 CREDIT
			2 COINS	2 CREDITS
			3 COINS	3 CREDITS
			4 COINS	4 CREDITS
			5 COINS	6 CREDITS
SETTING #27	FREE PLAY		FREE PLAY	

Table 2: COIN/CREDIT SETTING (COIN CHUTE INDIVIDUAL TYPE)

NAME OF SETTING	EACH SEAT'S COIN CHUTE	NAME OF SETTING	EACH SEAT'S COIN CHUTE
SETTING #1	1 COIN 1 CREDIT	SETTING #21	5 COINS 1 CREDIT
SETTING #2	1 COIN 2 CREDITS	SETTING #23	2 COINS 1 CREDIT
SETTING #3	1 COIN 3 CREDITS		4 COINS 2 CREDITS
SETTING #4	1 COIN 4 CREDITS		5 COINS 3 CREDITS
SETTING #5	1 COIN 5 CREDITS	SETTING #25	1 COIN 1 CREDIT
SETTING #11	1 COIN 6 CREDITS		2 COINS 2 CREDITS
SETTING #12	2 COINS 1 CREDIT		3 COINS 3 CREDITS
SETTING #15	1 COIN 1 CREDIT 2 COINS 3 CREDITS		4 COINS 4 CREDITS
SETTING #17	3 COINS 1 CREDIT		5 COINS 6 CREDITS
SETTING #18	4 COINS 1 CREDIT	SETTING #27	FREE PLAY
SETTING #19	1 COIN 1 CREDIT 2 COINS 2 CREDITS 3 COINS 3 CREDITS 4 COINS 5 CREDITS		

Table 3: MANUAL SETTING

COIN TO CREDIT	1 COIN 1 CREDIT
	2 COINS 1 CREDIT
	3 COINS 1 CREDIT
	4 COINS 1 CREDIT
	5 COINS 1 CREDIT
	6 COINS 1 CREDIT
	7 COINS 1 CREDIT
	8 COINS 1 CREDIT
	9 COINS 1 CREDIT

BONUS ADDER	NO BONUS ADDER
	2 COINS GIVE 1 EXTRA COIN
	3 COINS GIVE 1 EXTRA COIN
	4 COINS GIVE 1 EXTRA COIN
	5 COINS GIVE 1 EXTRA COIN
	6 COINS GIVE 1 EXTRA COIN
	7 COINS GIVE 1 EXTRA COIN
	8 COINS GIVE 1 EXTRA COIN
	9 COINS GIVE 1 EXTRA COIN

COIN CHUTE (#1 / #2) MULTIPLIER	1 COIN COUNTS AS 1 COIN
	1 COIN COUNTS AS 2 COINS
	1 COIN COUNTS AS 3 COINS
	1 COIN COUNTS AS 4 COINS
	1 COIN COUNTS AS 5 COINS
	1 COIN COUNTS AS 6 COINS
	1 COIN COUNTS AS 7 COINS
	1 COIN COUNTS AS 8 COINS
	1 COIN COUNTS AS 9 COINS



IMPORTANT

This game does not use SEQUENCE SETTING.
Do not change the SEQUENCE SETTING data.

○ SEQUENCE SETTING

When SEQUENCE SETTING is selected in either first or second screen, the SEQUENCE SETTING Mode (the third screen) appears.

In this mode, number of credits required for starting game can be set.

```

          COIN ASSIGNMENTS
          SEQUENCE SETTING

          SEQUENCE1 *CREDIT
          SEQUENCE2 *CREDIT
          SEQUENCE3 *CREDIT
          SEQUENCE4 *CREDIT
          SEQUENCE5 *CREDIT
          SEQUENCE6 *CREDIT
          SEQUENCE7 *CREDIT
          SEQUENCE8 *CREDIT
          > EXIT

          [ XXXXXXXXXXXXXXXXXXXXXXXX ]
          [ SEGA ENTERPRISES,LTD. ]
          DESCRIPTION OF SEQUENCE
          SEQ1 ****
          SEQ2 ****
          SEQ3 ****
          SEQ4 ****
          SEQ5 ****
          SEQ6 ****
          SEQ7 ****
          SEQ8 ****

          SELECT WITH SERVICE BUTTON
          AND
          PRESS TEST BUTTON

```

Each sequence can be set between 1 ~ 5.
Select EXIT to return to the first screen.

H. BOOKKEEPING

This allows such data as operating time/No. of coins inserted/ No. of credits to be checked, etc. This test consists of 2 screens. Pressing SERVICE Button causes screen to be changed. Press TEST Button to return to the MENU screen.

On the first screen, such data as total time, coin, and credit are displayed.

BOOKKEEPING			
TOTAL TIME	55H27M13S		
COIN1	16	SERVICE1	5
COIN2	4	SERVICE2	0
CREDIT	10		
TOTAL COIN	20		
COIN CREDIT	10		
SERVICE CREDIT	5		
TOTAL CREDIT	15		
PRESS SERVICE BUTTON TO ANOTHER PAGE			
PRESS TEST BUTTON TO EXIT			

- Total Time is displayed as "X X H X X M X X S" and no date will be displayed after exceeding 24 hours.
- The displays for number of coin and number of service vary depending on the CABINET TYPE set in SYSTEM ASSIGNMENTS.
Number of credit displays 1 if COIN CHUTE TYPE is set to COMMON in COIN ASSIGNMENTS. If COIN CHUTE TYPE is set to INDIVIDUAL, the applicable number in CABINET TYPE setting will be displayed.

On the second screen, each sequence displays the frequency of functioning.

BOOKKEEPING			
PLAYER1		PLAYER2	
SEQ1	1	SEQ1	0
SEQ2	0	SEQ2	1
SEQ3	1	SEQ3	0
SEQ4	0	SEQ4	1
SEQ5	0	SEQ5	0
SEQ6	0	SEQ6	0
SEQ7	0	SEQ7	0
SEQ8	0	SEQ8	0
PRESS SERVICE BUTTON TO ANOTHER PAGE			
PRESS TEST BUTTON TO EXIT			

I. BACKUP RAM CLEAR

Clears contents of BOOKKEEPING, operating time, coin/credit data, number of games played, etc.

```
BACKUP RAM CLEAR

YES (CLEAR)
> NO (CANCEL)

SELECT WITH SERVICE BUTTON
AND
PRESS TEST BUTTON
```

Selecting YES clears the aforementioned data. Select NO and press TEST Button to have the MENU mode return without clearing data.

Note that this does not affect the data of BOOKKEEPING in GAME TEST Mode. To clear the contents of BOOKKEEPING in GAME TEST Mode, enter into GAME TEST Mode and execute BACKUP DATA CLEAR.

J. ROMBD TEST

In this test, on-ROM-BD ROM check is executed. If GOOD is displayed, it is satisfactory. The IC No., TYPE, RESULT, BYTE, and WORD refers to the check sum of each unit. Press TEST Button to return to MENU mode.

```
ROMBD TEST
[XXXXXXXXXXXXXXXXXXXX]
[XXXXXXXXXXXXXXXXXXXXXXXXXXXXXXXXXXXX]

NO. TYPE RESULT BYTE WORD
IC29 32M ---- xxxx xxxx
IC30 32M ---- xxxx xxxx
IC31 128M GOOD  xxxx xxxx
.... .... .... .... ....
IC50 128M GOOD  xxxx xxxx

PRESS TEST BUTTON TO EXIT
```

K. CLOCK SETTING

YEAR, MONTH, DAY, HOUR, and MINUTE are set for SEGA HIKARU BD.
Select the desired item with SERVICE Button and press TEST Button to increase the value.
Bring the arrow to EXIT and press TEST Button to return to MENU Mode.

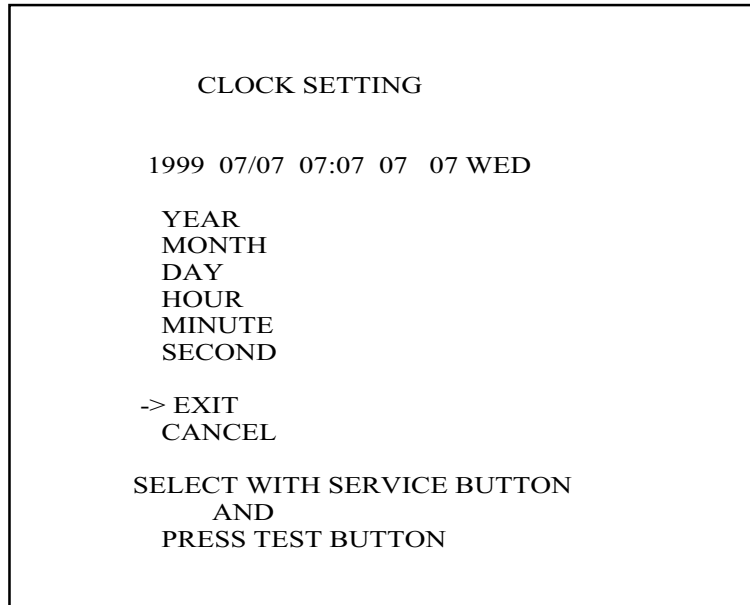

L. GAME TEST MODE

Enters the TEST Mode of the game connected to SEGA HIKARU BD. The TEST Mode includes INPUT Test, GAME ASSIGNMENTS such as game difficulty, etc. Refer to 9-3 for details.

9 - 3 GAME TEST MODE

A. MENU SCREEN

The Game Test Mode Menu Screen is displayed by selecting and executing "GAME TEST MODE" on the System Test Menu Screen. In the Game Test Mode, you should perform the tests and settings about the I/O devices dedicated to this product.

Operation method is same as in the SYSTEM TEST MODE. By pressing SERVICE Button, move the arrow to the desired item and press TEST Button to execute/change the selected item.

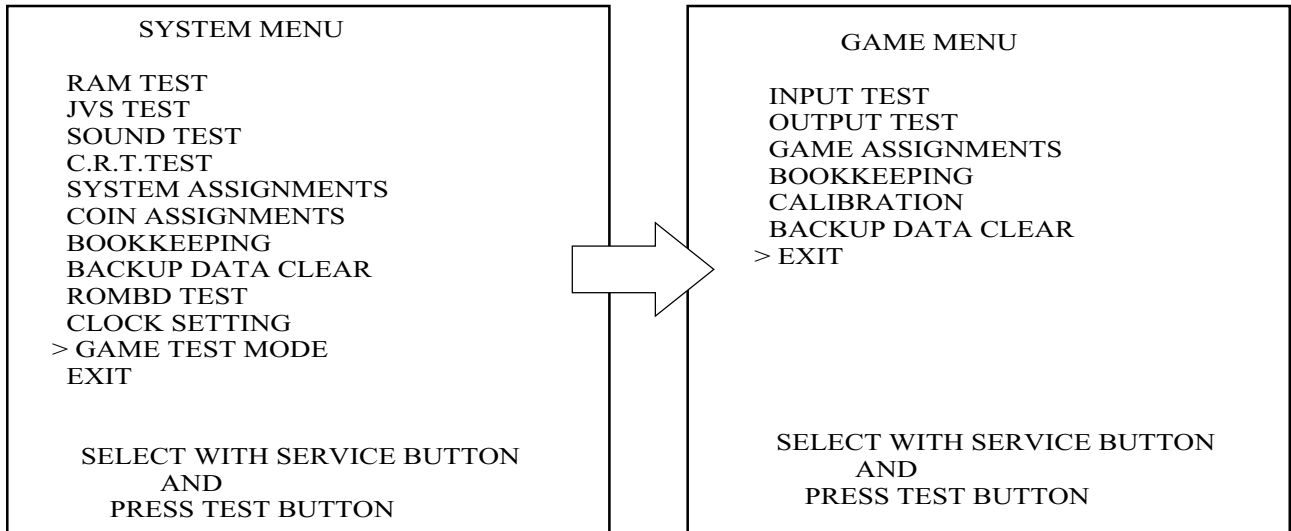

FIG. 9. 3 a GAME TEST MODE MENU screen

B. INPUT TEST



In this mode, the Skate Board is unlocked. Entering this mode while the player is on the Skate Board can cause falling down accidents. Use care to avoid injury.

Selecting "INPUT TEST" displays the following screen, where you can view the switch settings and the Volume Control values of each cabinet.

Periodically check the switch and Volume Control settings on this screen.

If the indicator to the right of the name of a switch turns "ON" from "OFF" when the switch is pressed, this switch and its wiring are normal.

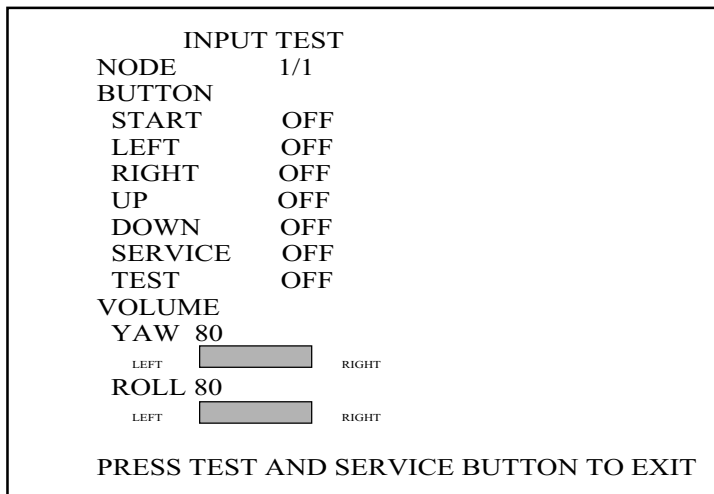
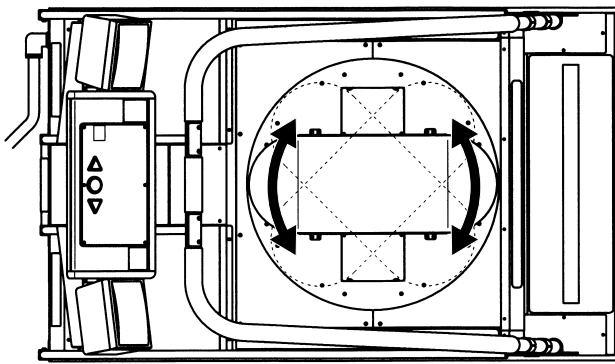
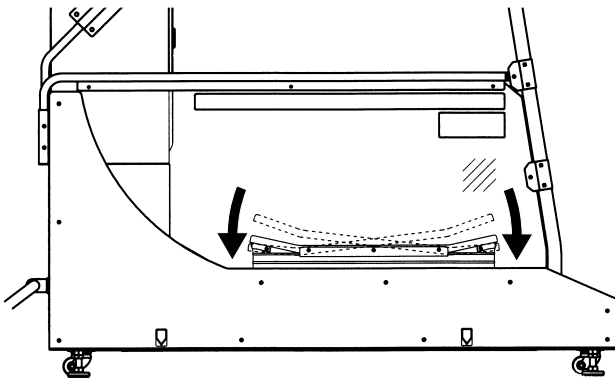

FIG. 9. 3 b a INPUT TEST screen

- UP and DOWN indicate the status of the sensors that detect kicking on the front and back of the Controller Board (i.e., Skateboard). (FIG. 9.3bb).
- YAW is the Volume Control value with which the left and right swings of the Skateboard are detected. ROLL is the Volume Control value with which the tilt relative to the horizontal surface is detected. (FIG. 9.3bb).
- Pressing the TEST and SERVICE Buttons together causes the Menu Screen to return.



YAW



UP, DOWN

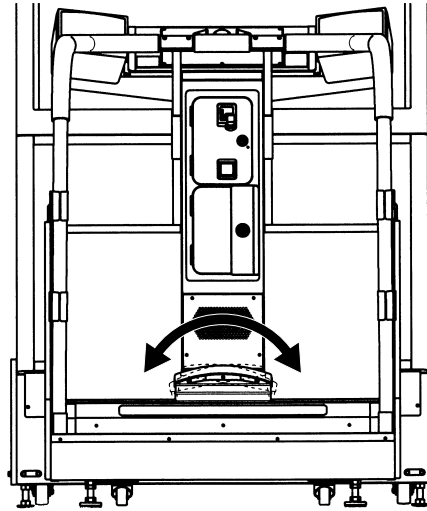

ROLL

FIG. 9.3 b b

At the time of centering the Volume (the Controller Board is level and faces the front), the Volume value is set to $180H \pm 08$, and if the Volume value varies in a natural manner matching the operation of the Controller Board and meeting the operation in the right/left direction evenly, then the product allows for satisfactory play.

If the Volume value is widely deviated from the $80H \pm 08$ which is set at the time of centering, or the value does not vary evenly in the right/left operation, the game can not be played satisfactorily, and also this causes Volume damage. Adjust the Volume by referring to "F. CALIBRATION", or adjust the gear engagement of the Volume by referring to Section 10, or replace the Volume.

C. OUTPUT TEST



In this mode, the Skate Board is unlocked. Entering this mode while the player is on the Skate Board can cause falling down accidents. Use care to avoid injury.

Selecting "OUTPUT TEST" displays the following screen, where you can view the lamp positions.

Select the desired item using the SERVICE Button. Then press the TEST Button. The indicator to the right of the name of the currently selected item turns "ON" from "OFF".

If the lamp associated with the selected item lights up and the Skateboard is locked when the indicator is "ON", the functionality is normal.

Pressing the TEST Button causes the Menu Screen to return.

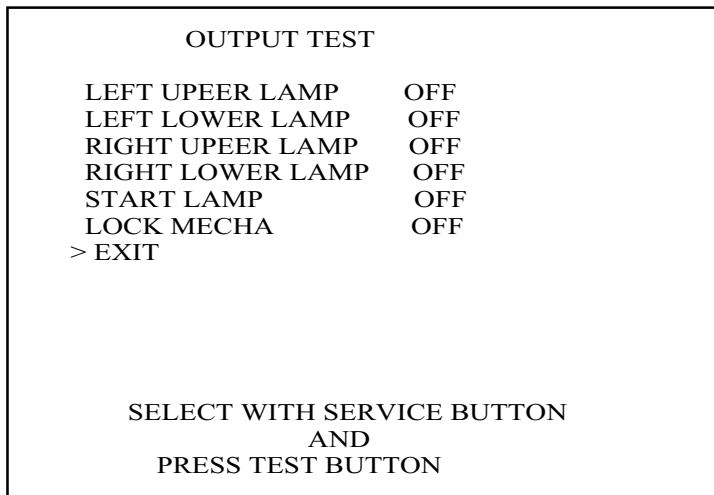

FIG. 9. 3 c a OUTPUT TEST screen

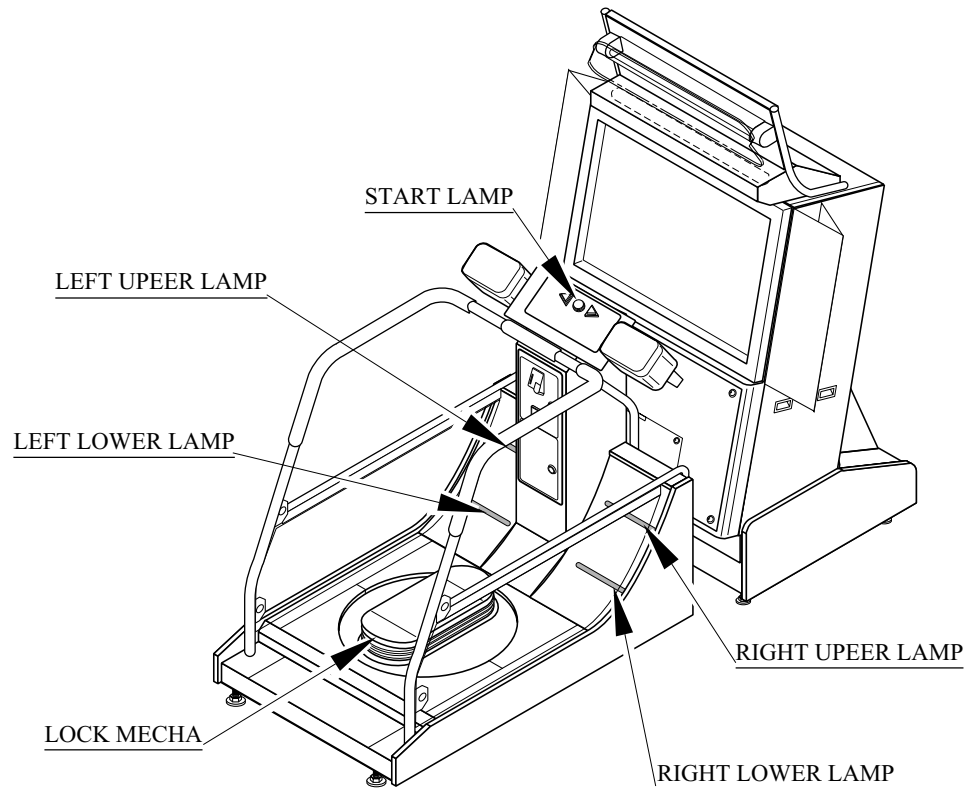

FIG. 9. 3 c b

D. GAME ASSIGNMENTS

Selecting "GAME ASSIGNMENTS" displays the following screen, where you can make the settings about the game.

If change is made to the settings, return to the Menu Screen and select and execute EXIT to exit the TEST MODE. The new settings will not take effect unless the TEST MODE is exited.

The items represent the following:

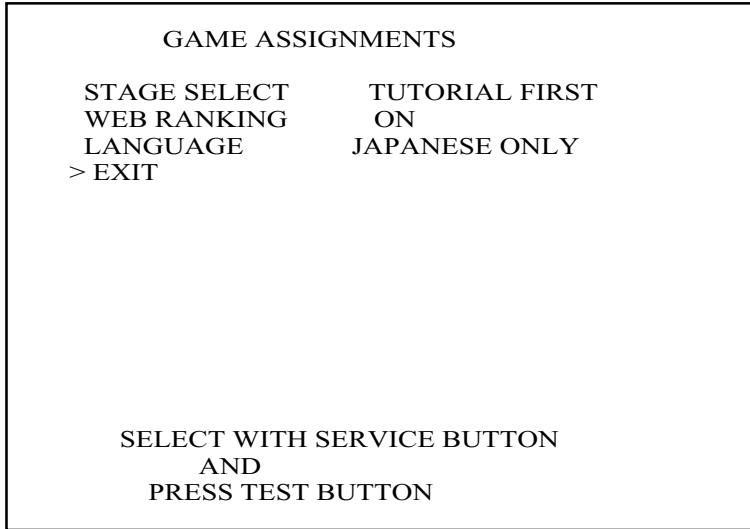

FIG. 9. 3 d GAME ASSIGNMENTS screen

● STAGE SELECT

Set the stage that was selected first when the Select Stage Screen appears before the game starts. Select either SCORE ATTACK FIRST (center) or TUTORIAL FIRST (left).

The stage being selected first is only set, but the restrictions to player selection are not set.

● WEB RANKING

ON : The URL of the home page is displayed during the Advertise Mode, or the password for the home page is displayed when the game is over.

OFF : Neither the URL nor the password is displayed.

● LANGUAGE

Select the desired language from FRANCOIS, ESPANOL, ITALIAN, and ENGLISH.

SETTING CHANGE PROCEDURE

- ① Press the SERVICE Button to bring the arrow (>) to the desired setting change item.
- ② Press the TEST Button to choose the desired setting item.
- ③ Bring the arrow to EXIT and press the TEST Button to return to the menu mode.

E. BOOKKEEPING

You can view data about the game play time etc.
Pressing the TEST Button causes the Menu Screen to return.

BOOKKEEPING	
NUMBER OF GAME	0
TUTORIAL	0
SET-A	0
SET-B	0
PLAY TIME	0H 0M 0S
SHOTEST TIME	0M 0S
LONGEST TIME	0M 0S
AVERAGE TIME	0M 0S
CHARACTER COUNT	
JAKE	0
SPIDEY	0
KYATIE	0
LINDA	0
TONY	0
PRESS TEST BUTTON TO EXIT	

FIG. 9. 3 a BOOKKEEPING screen

- NUMBER OF GAMES : Number of games that were played.
- TUTORIAL : Number of games that were played by selecting the left stage on the Select Screen.
- SET-A : Number of games that were played by selecting the central stage on the Select Screen.
- SET-B : Number of games that were played by selecting the right stage on the Select Screen.
- PLAY TIME : Total time of games played.
- CHARACTER COUNT : Count of selection made for each character.

F. CALIBRATION



CAUTION!

In this mode, the Skate Board is unlocked. Entering this mode while the player is on the Skate Board can cause falling down accidents. Use care to avoid injury.



IMPORTANT

When the Volume is adjusted or replaced, be sure to set the Volume value in the CALIBRATION mode.

Selecting CALIBRATION on the Menu Screen displays the following screen. You can determine the YAW and ROLL Volume Control values with which operation of the Skateboard is detected.

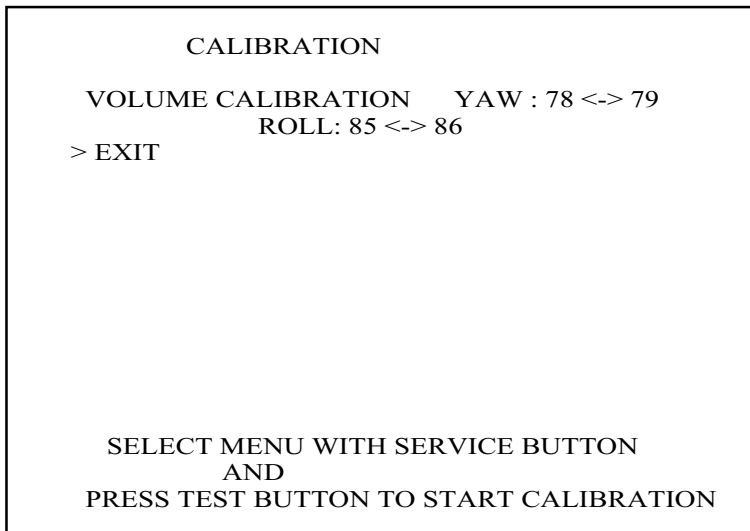

FIG. 9. 3 f a CALIBRATION screen

HOW TO VOLUME SETTING

- ① Select "VOLUME CALIBRATION" using the SERVICE Button. Then press the TEST Button. The screen changes to the one shown in FIG. 9.3fb.
- ② Get on the Skateboard. Then, set the minimum and maximum values of the Volume Control by operating YAW (left-right) and ROLL (tilt) even in both directions. If a large width of input is set, the Skateboard will be hard to make a turn. If a small width of input is set, it will be easy to make a turn.
- ③ Pressing the SERVICE Button exits VOLUME CALIBRATION.
- ④ With EXIT selected, pressing the TEST Button causes the Menu Screen to return.

If the Volume Control value is not set within 80 ± 08 H when the Skateboard is horizontally placed in the progressive direction, improper engagement of the Volume Control gears or the Volume Control itself may be faulty. Take the proper action according to the instructions in Section 10.

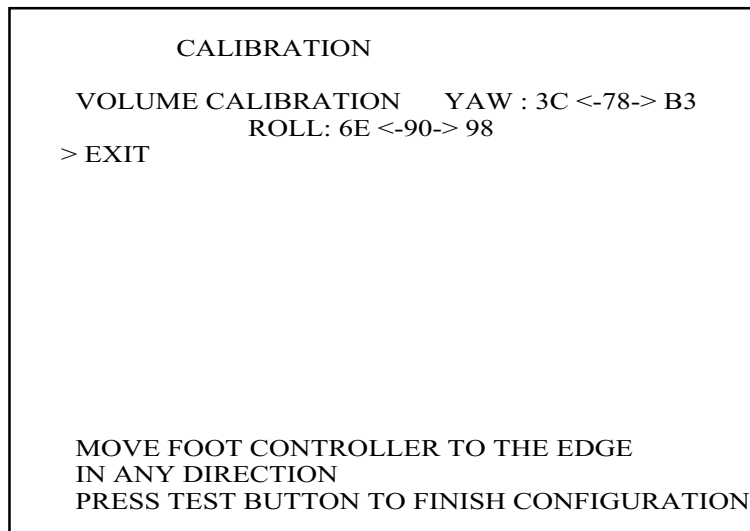
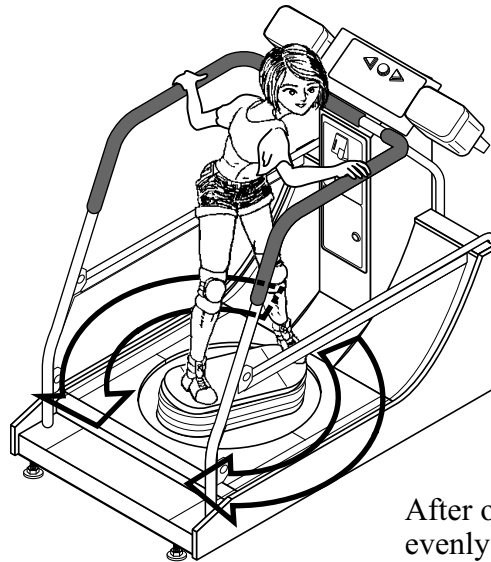

FIG. 9. 3 f b CALIBRATION screen



After operating the Skate Board evenly in both directions.

FIG. 9. 3 f c

G. BACKUP DATA CLEAR

This screen enables to clear the data of bookkeeping and to initialize the high-scorer ranking data.

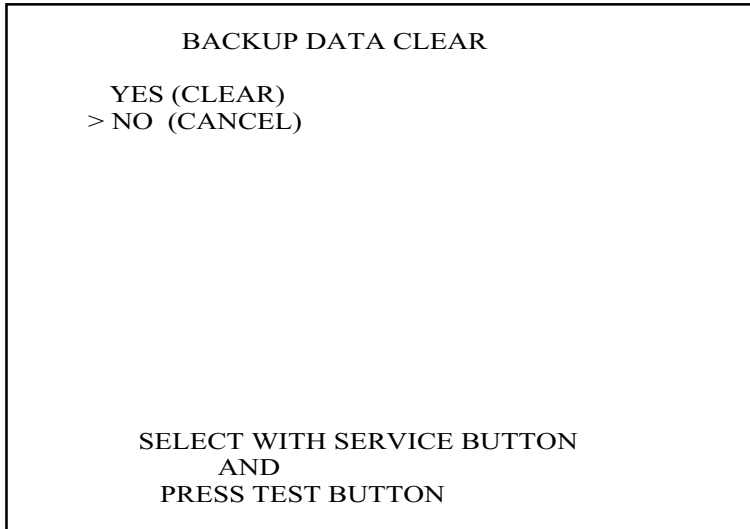

FIG. 9. 3 g BACKUP DATA CLEAR screen

- * To clear the data:
Press the SERVICE Button to move the > mark to YES, and press the TEST Button. When clearing is finished, the COMPLETED message appears on the screen. Press the TEST Button, in this instance, to return to the GAME TEST MODE screen.
- * Not to clear the data:
Press the SERVICE Button to move the > mark to NO, and press the TEST Button. This action enables you to immediately return to the GAME TEST MODE screen.
- * What you can clear on this screen is the bookkeeping data accessible from the GAME TEST MODE screen. You cannot clear the bookkeeping data and settings accessible from the SYSTEM MENU screen.

10. MAINTENANCE OF CONTROLLER MECHANISM UNIT



- Before starting to work, ensure that the Power SW is OFF. Failure to observe this can cause electric shock or short circuit.
- Use care so as not to damage wirings. Damaged wiring can cause electric shock or short circuit.
- Do not touch undesignated places. Touching places not designated can cause electric shock or short circuit.
- This work should be performed by the Location's Maintenance Man or Serviceman. Performing work by non-technical personnel can cause electric shock hazard.
- Do not perform work other than those specified in this Manual in order to prevent accidents during performing work and operation after performing work. Performing work not specified in this Manual may require special training for this product. If performing work other than those stated in this manual is required for repair, contact the offices herein stated in this manual or where you purchased the product from and ask for repair or inquire how to repair.
- Take care not to get caught in the gears or the Mechanism Assembly. If you encounter such an accident, you may be seriously injured (e.g., a bone fractures, or of your body is cut).
- Take care not to lose any fasteners or their related parts (e.g., screws, bolts, washers). If a metallic fastener or its related part touches a conductive part, a short circuit or fire may be caused.

The Skateboard (i.e., Controller Board) is equipped with the following operational input devices: a ROLL- and a YAW-direction detection Volume Control and a kicking sensor. Verify operation of the input devices in the Test Mode at least once a month. If a failure is found, take action immediately. This document explains how to adjust and replace a spare Volume Control.

The Mechanism Assembly is required to be greased up.

10 - 1 ADJUSTING/REPLACING THE ROLL-DIRECTION VOLUME CONTROL

The Volume Control used to detect the Skateboard ROLL-direction (tilt) is located under the Skateboard, toward the rear.

The following work requires a Phillips screwdriver for M4 screws, a flat-tipped screwdriver for M3 screws, and a wrench with an inter-opposite side distance of 11 mm.

- ① Turn off power.
- ② Remove the 6 Bellows Holder securing the bellows located under the Skateboard. Remove the 2 screws.

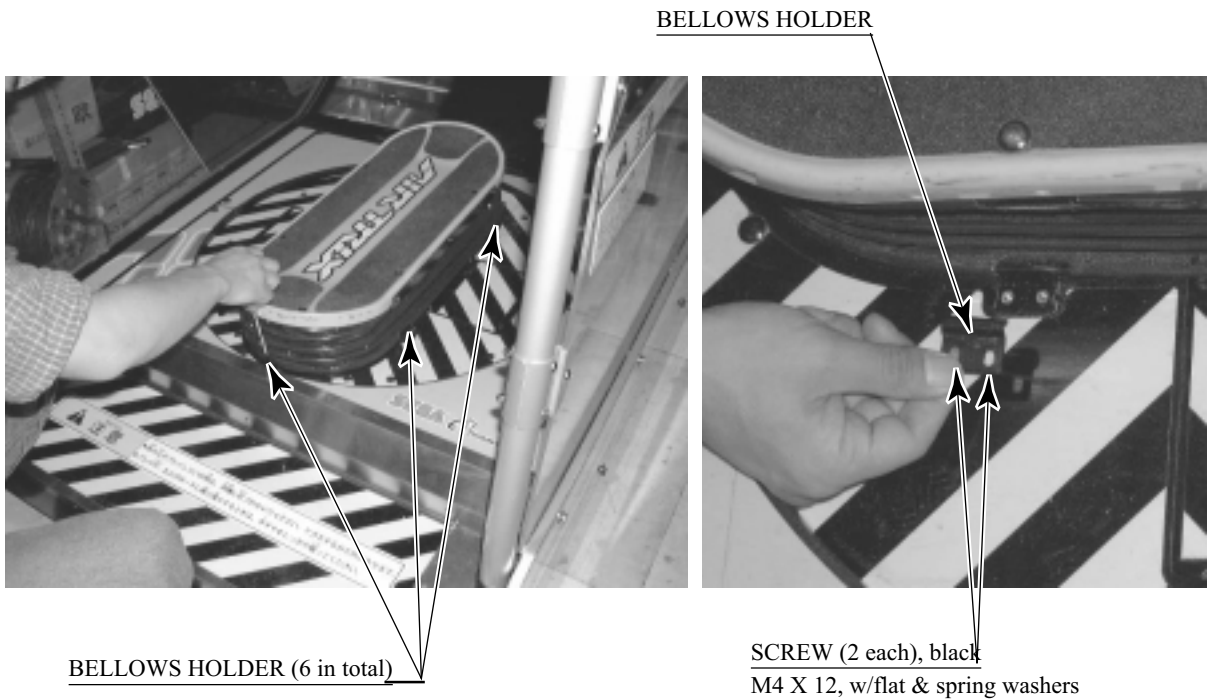

PHOTO 10. 1 a

- ③ Remove the 2 truss screws located on the top surface of Floor Board Rear.



PHOTO 10. 1 b

- ④ Remove the 3 truss screws from the back of the Rear Cabinet.

TRUSS SCREW (3)
M4 X 8, chrome plated



PHOTO 10. 1 c

- ⑤ Remove Floor Board Rear.
The ROLL-direction Volume Control Mechanism Assembly is seen by raising the bellows.

FLOOR BOARD REAR



PHOTO 10. 1 d

Adjusting Procedure

- ① Loosen the 2 screws securing the ROLL VR Holder.

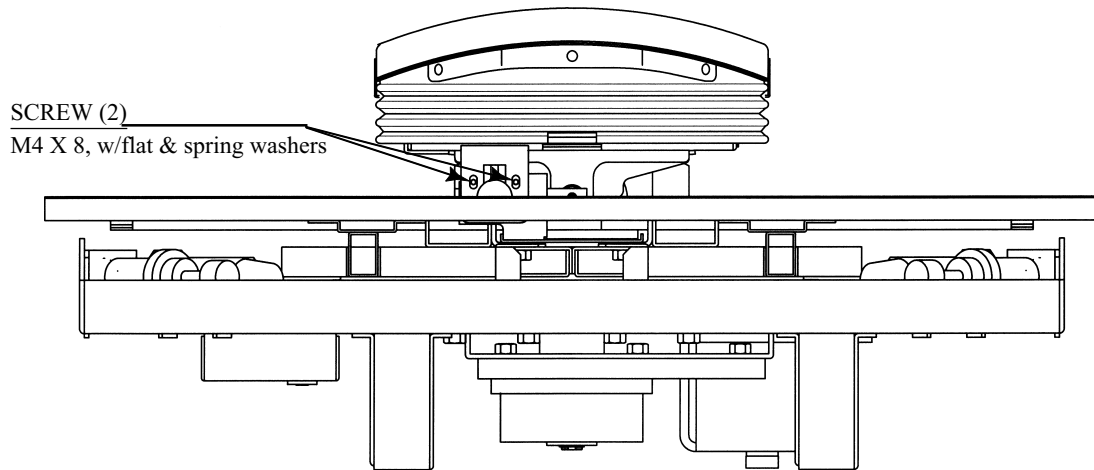

FIG. 10. 1 a

- ② Adjust the top and bottom positions of the ROLL VR holders so that the D-Cut side of the Volume Control spindle faces up when the Skateboard is placed horizontally.
- ③ Retighten the 2 loosened screws.
- ④ With power on, check the volume control values in the Test Mode. (See Section 9-3 B)

Replacing Procedure

- ① Pull out the connector connected to the Volume Control. Then unfasten the wire.

Disconnect the connector.

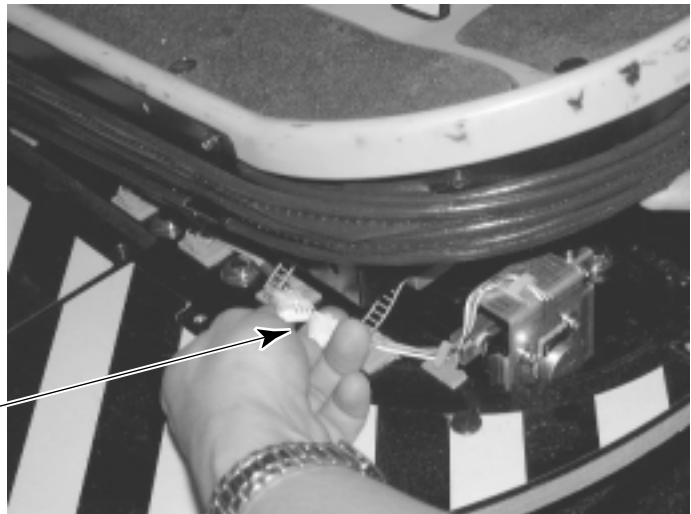

PHOTO 10. 1 e

- ② Remove the 2 screws securing the ROLL VR Holder.

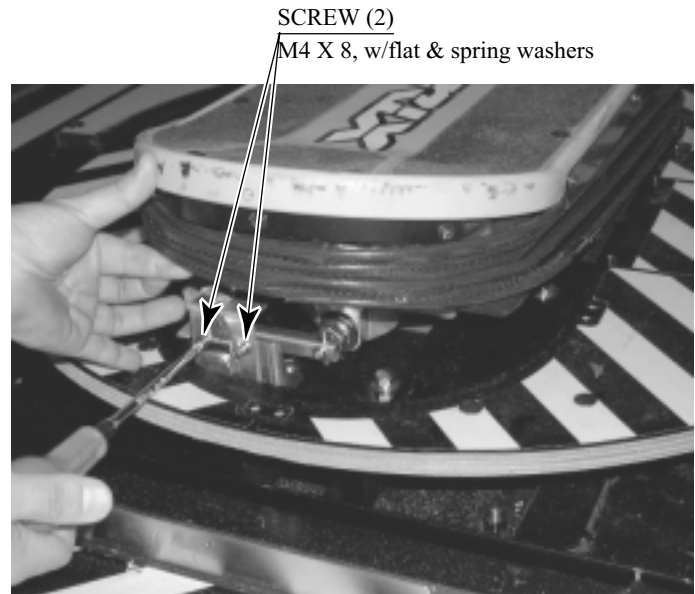

PHOTO 10. 1 f

- ③ Remove the ROLL VR Holder with the Volume Control installed.

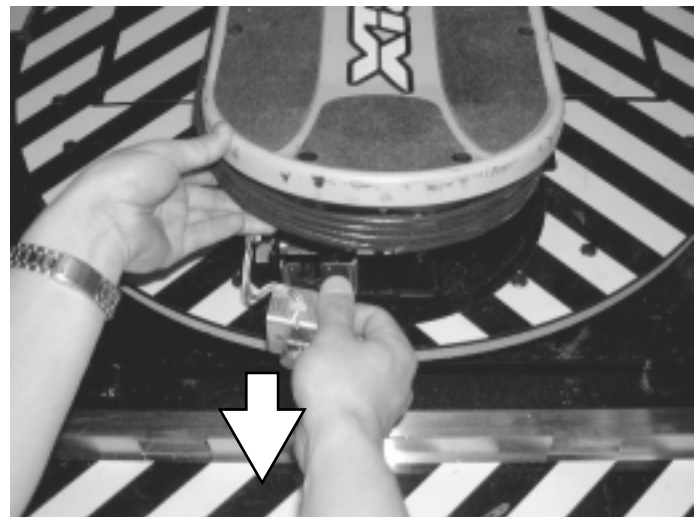
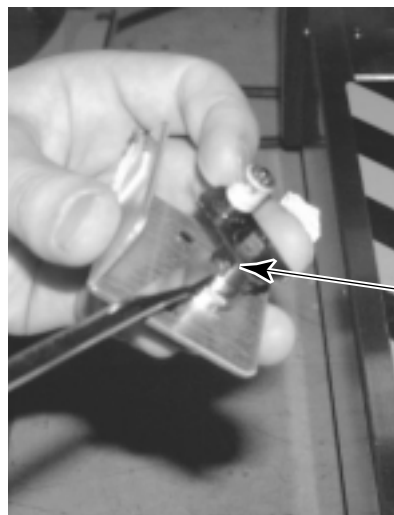

PHOTO 10. 1 g

- ④ Loosen the 2 cheese machine screws securing the crank.



CHEESE MACHINE SCREW (2)
M3 X 6

PHOTO 10. 1 h

- ⑤ Pull out the crank from the Volume Control spindle.

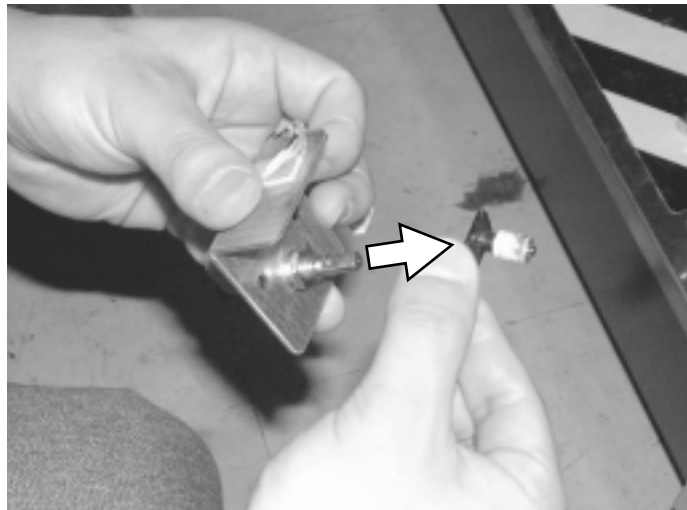

PHOTO 10. 1 i

- ⑥ Remove the hexagon nut securing the Volume Control to the ROLL VR Holder.

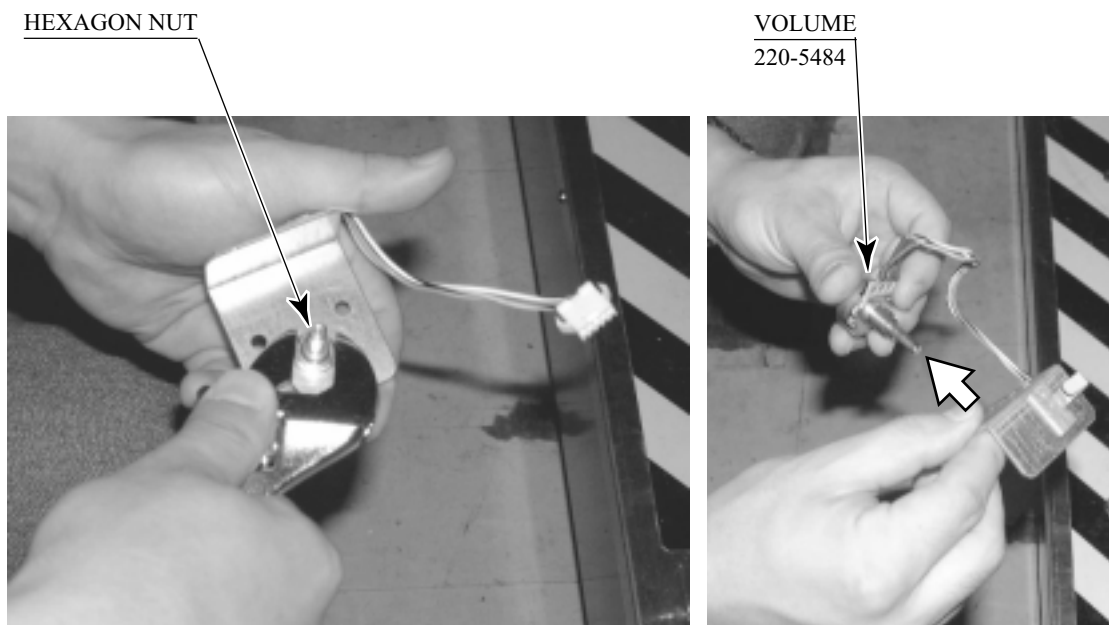

PHOTO 10. 1 j

- ⑦ To replace the Volume Control, remove it from the ROLL VR Holder.
- ⑧ Install a new Volume Control to the ROLL VR Holder, and secure the crank. Paying attention to the angle of installation illustrated in the figure, secure the ROLL VR Holder. (See FIG. 10.1a.)
- ⑨ Connect the connector and secure the wire firmly. The wire may be disconnected by being caught in the Mechanism Assembly. Check that there is not the danger that movement of the Mechanism Assembly to either limit of the movable range may damage the wire.
- ⑩ With power on, adjust the Volume Control values in the Test Mode. (See Section 9-3F)

10 - 2 ADJUSTING/REPLACING THE YAW-DIRECTION VOLUME CONTROL

The Volume Control used to detect the Skateboard YAW direction (turn) is located under Table Lid L to the left of the Skateboard when facing the PTV screen.

The following work requires a Phillips screwdriver for M4 screws, a flat-tipped screwdriver for M3 screws, and a wrench with an inter-opposite side distance of 11 mm.

- ① Turn off power.
- ② Remove the 2 screws securing Table Lid L, located to the left of the Skateboard.

SCREW (2), black
M4 X 20, w/flat & spring washers



PHOTO 10. 2 a

- ③ Table Lid L can be removed by sliding it toward the Skateboard.
The YAW-direction Volume Control Mechanism Assembly is seen by removing Table Lid L.

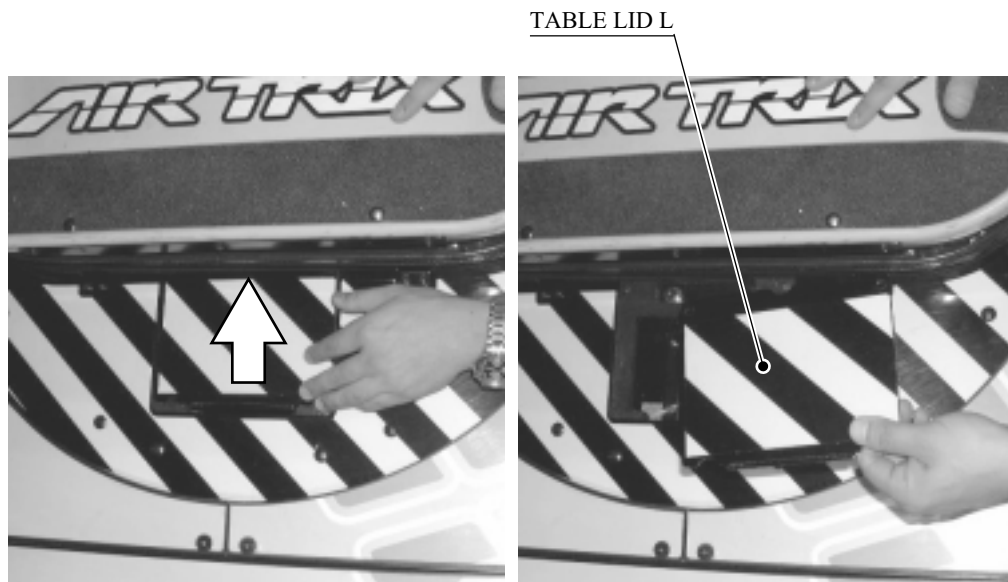

PHOTO 10. 2 b

Adjusting Procedure

- ① Loosen the 2 screws securing the YAW VOL Holder.
- ② Adjust the angle for securing the YAW VOL Holder so that, when the Skateboard is placed in the progressive direction, the D-Cut side of the Volume Control spindle faces left.
- ③ Retighten the 2 loosened screws for securing.
- ④ With power on, check the Volume Control values in the Test Mode. (See Section 9-3B)

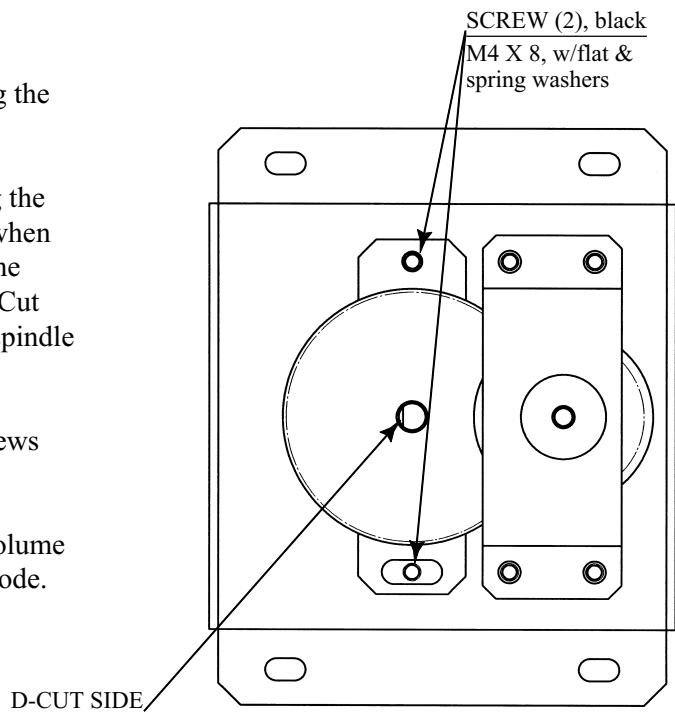

FIG. 10. 2 a

Replacing Procedure

- ① Pull out the connector connected to the Volume Control. Then unfasten the wire.

Disconnect the connector.

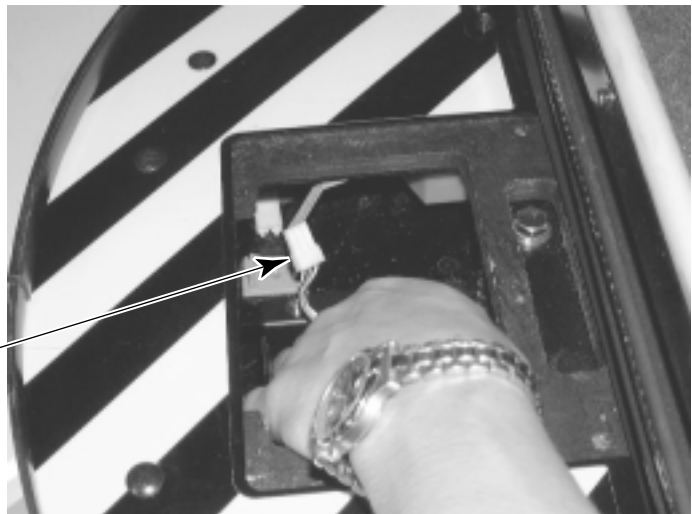

PHOTO 10. 2 c

- ② Remove the 2 screws securing the YAW VOL Holder.

SCREW (2), black
M4 X 8, w/flat & spring washers

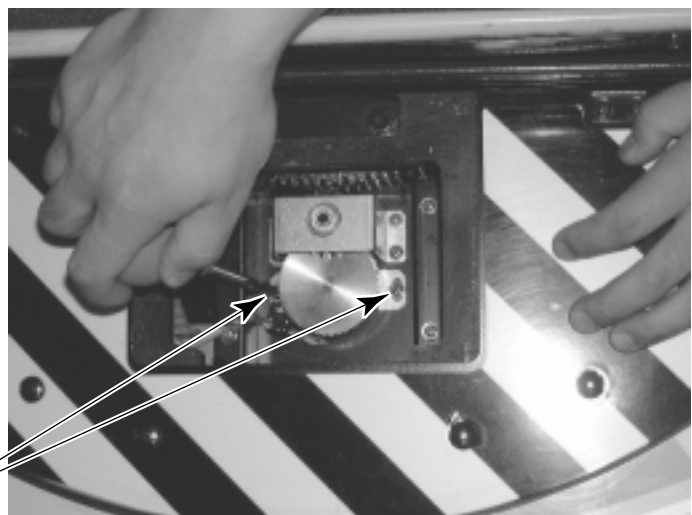

PHOTO 10. 2 d

- ③ With the Volume Control installed, remove the YAW VOL Holder.

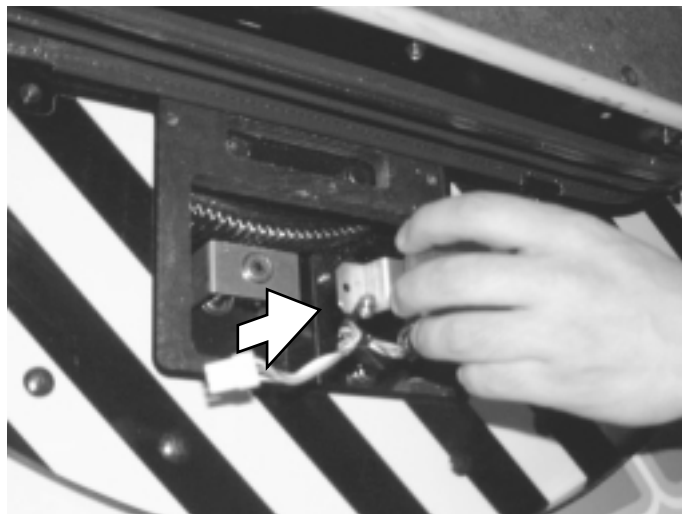

PHOTO 10.2 e

- ④ Loosen the 2 cheese machine screws securing the Gear Wheel.

CHEESE MACHINE SCREW (2)
M3 X 6

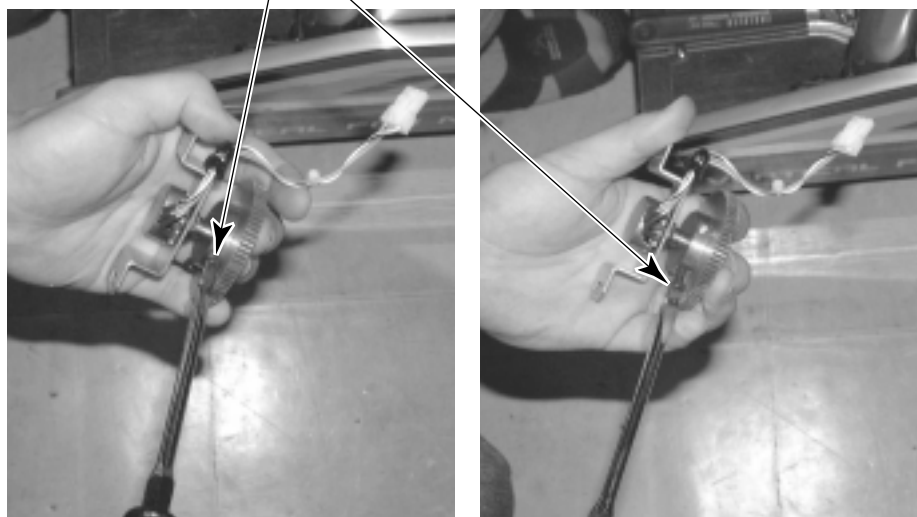

PHOTO 10.2 f

- ⑤ Draw out the Gear Wheel from the Volume Control spindle.

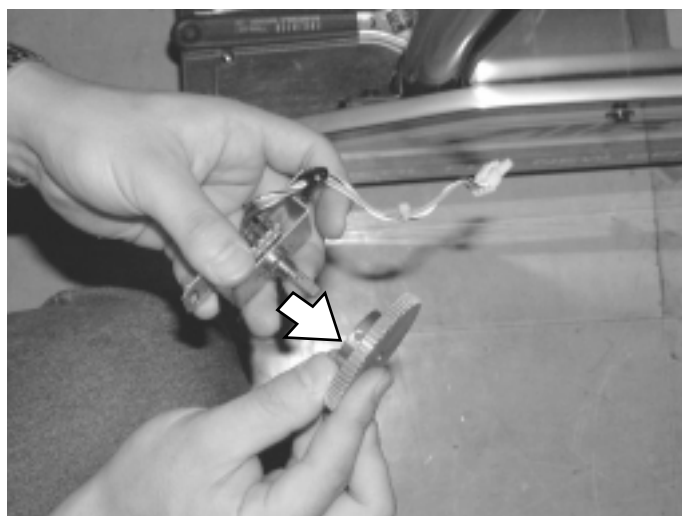

PHOTO 10.2 g

- ⑥ Remove the hexagon nut securing the Volume Control to the YAW VOL Holder.

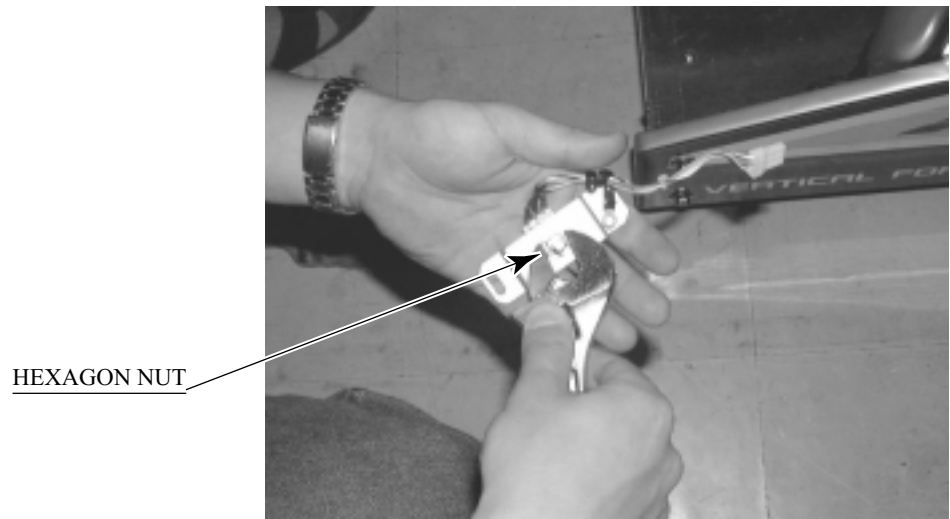

PHOTO 10. 2 h

- ⑦ To replace the Volume Control, remove it from the YAW VOL Holder.

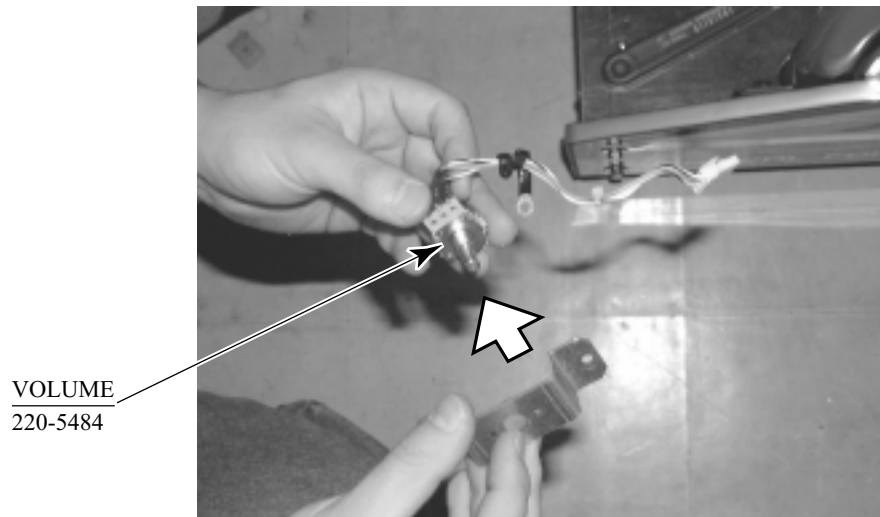

PHOTO 10. 2 i

- ⑧ Install a new Volume Control to the YAW VOL Holder, and secure the gear wheel. Paying attention to the angle of installation illustrated in the figure, secure the YAW VOL Holder. (See FIG. 10.2a.)
- ⑨ Connect the connector and secure the wire firmly. The wire may be disconnected by being caught in the Mechanism Assembly. Check that there is not the danger that movement of the Mechanism Assembly to either limit of the movable range may damage the wire.
- ⑩ With power on, adjust the Volume Control values in the Test Mode. (See Section 9-3F)

10 - 3 GREASING



WARNING!

- Grease is inflammable and must never be close to fire.
- Grease may be apt to be erroneously used or drunk, and must not be placed in a location where children can access.



CAUTION!

- Grease does harm to your body if you aspirate it. Do not perform any work related to grease in a location where ventilation is insufficient.
- If grease enters an eye, eye irritation may be caused. Take care to prevent it from entering your eyes (for example, by wearing protective goggles). Should grease enter an eye, rinse it in clean water and have your illness diagnosed by a doctor.
- If grease touches a human skin, skin irritation may be caused. Take care to prevent grease from touching your skin (for example, by wearing protective gloves). Should grease touch your skin, fully wash it using water and soap.
- Do not eat grease. Should you eat it, you may have loose bowels or feel like vomiting. Should somebody swallow it, immediately have his or her illness diagnosed by a doctor, without compelling him or her to vomit the grease.
- When attempting to open the bottle of grease, your hand may be cut. To prevent this, use protective gloves.
- The way of treating grease is regulated by law. Treat it legally according to the local law for the setup site. Illegal treatment of grease may cause environmental pollution. If you do not know how to treat grease, contact the dealer from which you bought it.



IMPORTANT

- Be sure to use the designated type of grease. If a non-designated type grease is used, components may break.
- To prevent dust or water from mixing into the grease, firmly cork the grease bottle for sealing.
- Store the grease in a dark place not exposed to direct sunlight.
- The period for greasing specified herein is a standard. Apply greasing to the specified portions as occasion arises.

Grease the swing bearing, once a month, with the Special Grease accompanying the product. In addition, grease the gear mesh portion and the crank sliding portion of the Volume Control Mechanism Assembly, and the mesh portion of the pinion gears (for locking the Skateboard).

Greasing the Swing Bearing



When greasing the swing bearing, move the Skateboard fully to the clockwise or counterclockwise end to allow grease to reach every part of the bearing. When performing this work, hold the handrail firmly to prevent you from falling down.



- For the swing bearing, be sure to use the Special Grease accompanying the product. The same type of grease is injected for shipment. Using another type of grease may cause a chemical change, thereby causing the system to be unavailable or hang up.
- When the Special Grease is used up, place an order with your dealer for another bottle of grease.
- When operating the Grease Gun lever, be sure to either open or close fully. If it is operated halfway, the grease cannot be injected.
- If the grease does not come out when the lever is operated, this may be due to an air pocket in the grease. To resolve this, warm the Lubricant Tube once or twice to release the air.
- The weight of grease used at a time should be 16 g. Injecting more grease results in the same effect.

To grease the swing bearing, prepare the following:

- Grease Gun (540-0064)
- Special Grease (090-0275)
- Protective goggles
- Protective gloves
- Phillips screwdriver for M4 screws
- Master key

- ① Remove Table Lid R, which is located to the right of the Skateboard when facing the PTV screen. Remove the 2 screws securing it.

SCREW (2), black
M4 X 20, w/flat & spring washers

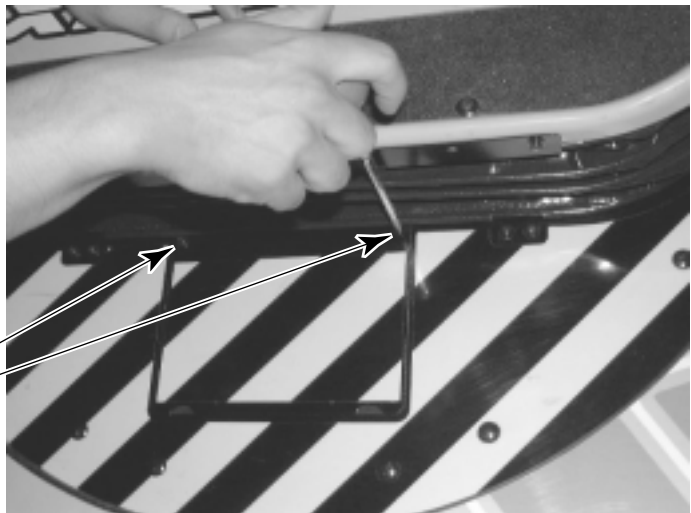

PHOTO 10. 3 a

② Table Lid R can be removed by sliding toward the Skateboard.

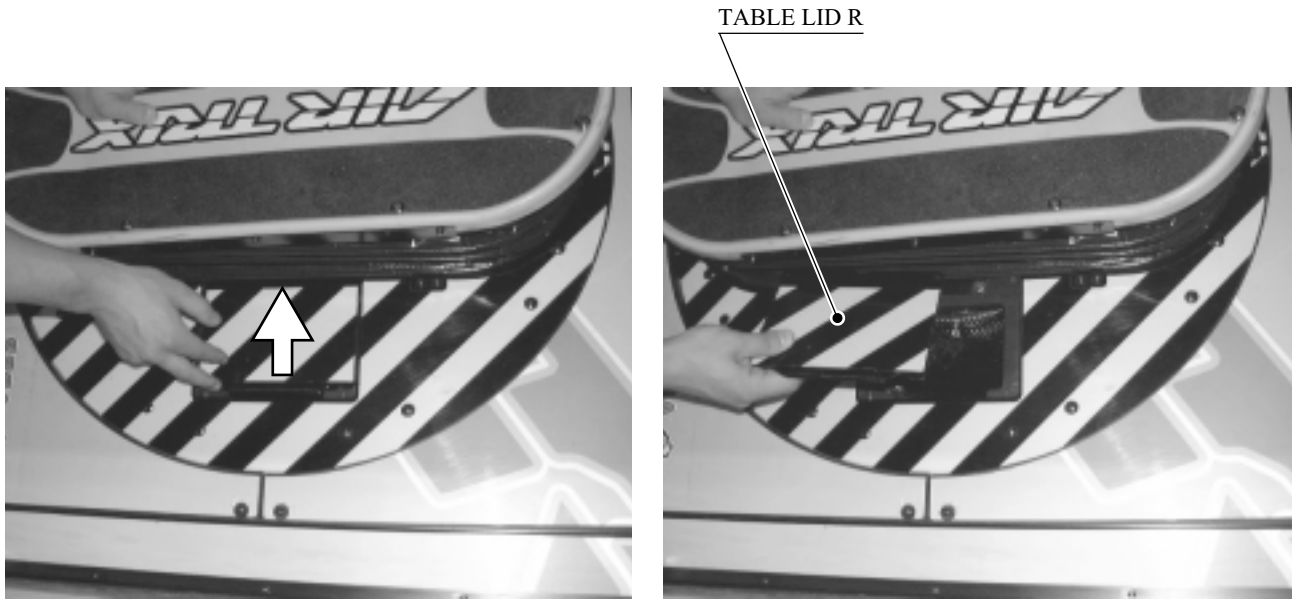

PHOTO 10. 3 b

Once Table Lid R is removed, the Grease Nipple for greasing is seen.

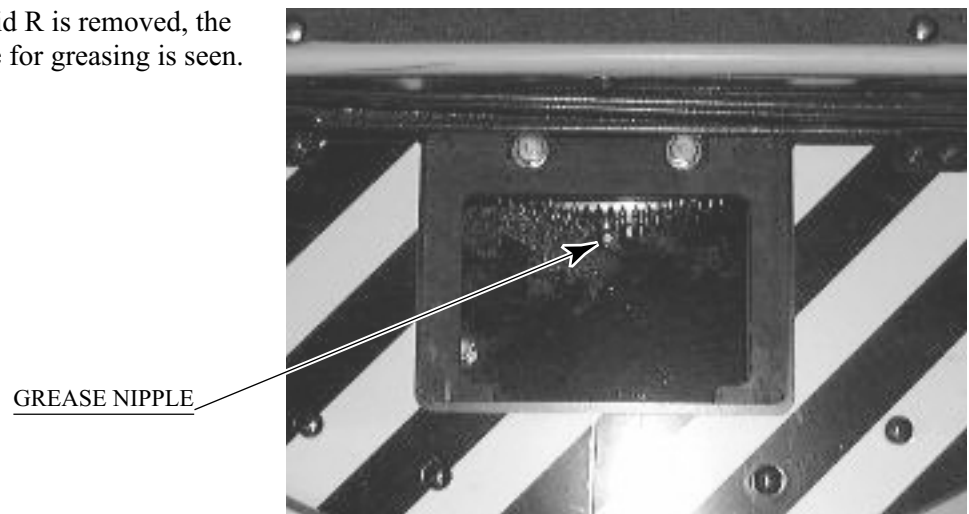

PHOTO 10. 3 c

③ Install the Grease Gun nozzle to the body of the gun.

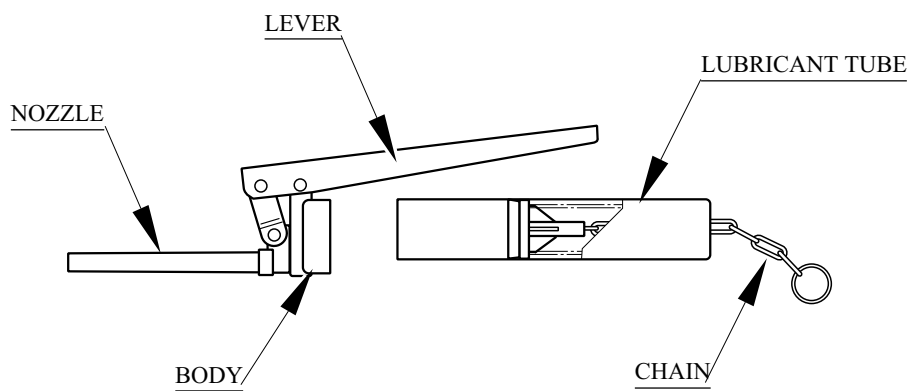

FIG. 10. 3 a

- ④ Screw back the Lubricant Tube to remove it from the body.



PHOTO 10. 3 d

- ⑤ Pull the chain to lock it to the grooves in the Lubricant Tube.

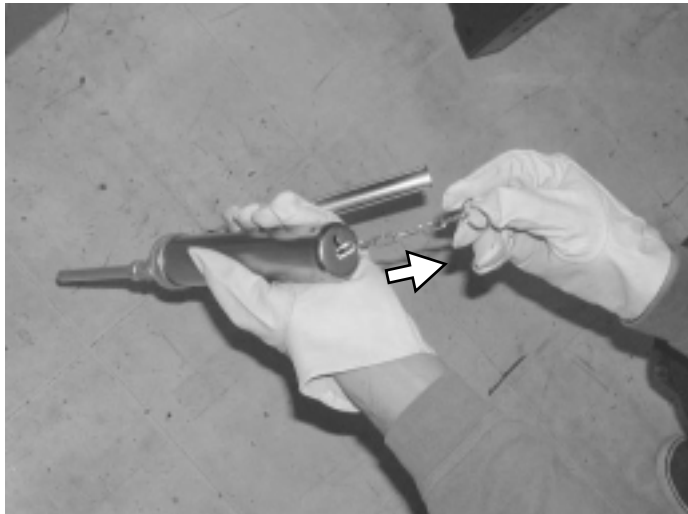

PHOTO 10. 3 e

- ⑥ Remove the cap from the Special Grease bottle, and directly pour it into the Lubricant Tube.
At this time, take care not to allow air or dust to mix into the grease.



PHOTO 10. 3 f

- ⑦ Return the Lubricant Tube to the body as before.



PHOTO 10. 3 g

- ⑧ Unlock the chain and store it in the Lubricant Tube.

- ⑨ While moving the lever between the opposite ends twice or three times, checking that the grease comes out from the tip of the nozzle.

- ⑩ Enter the Test Mode and unlock the Skateboard.
(See Section 9-3B or C)

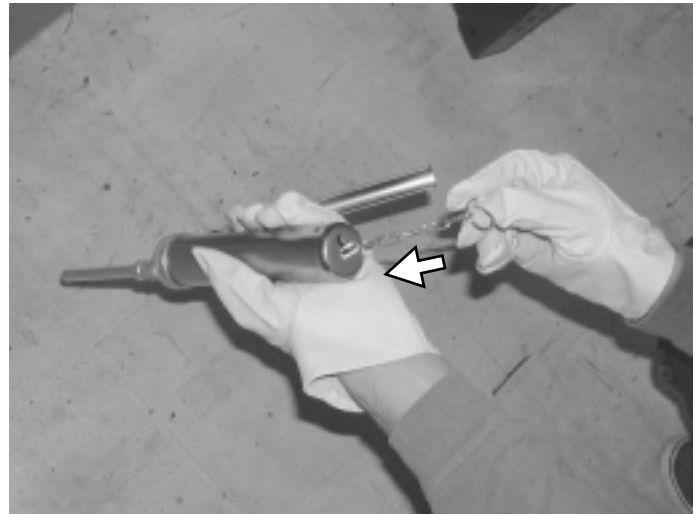

PHOTO 10. 3 h

- ⑪ With the Skateboard turned fully to either the clockwise or counterclockwise end, insert the Grease Gun nozzle into the Grease Nipple.

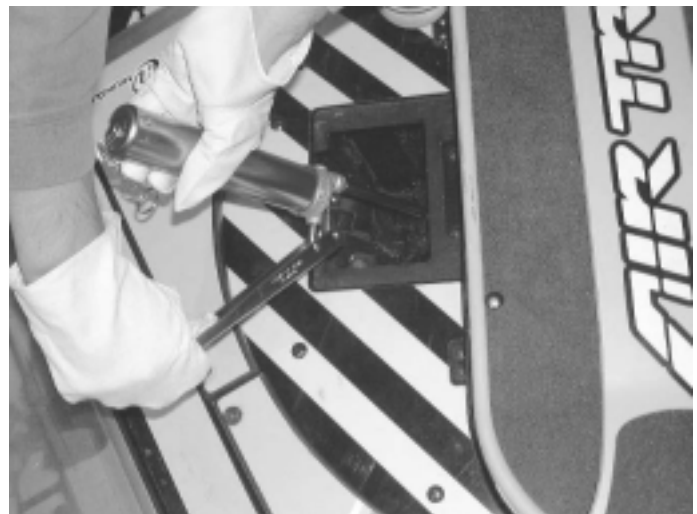

PHOTO 10. 3 i

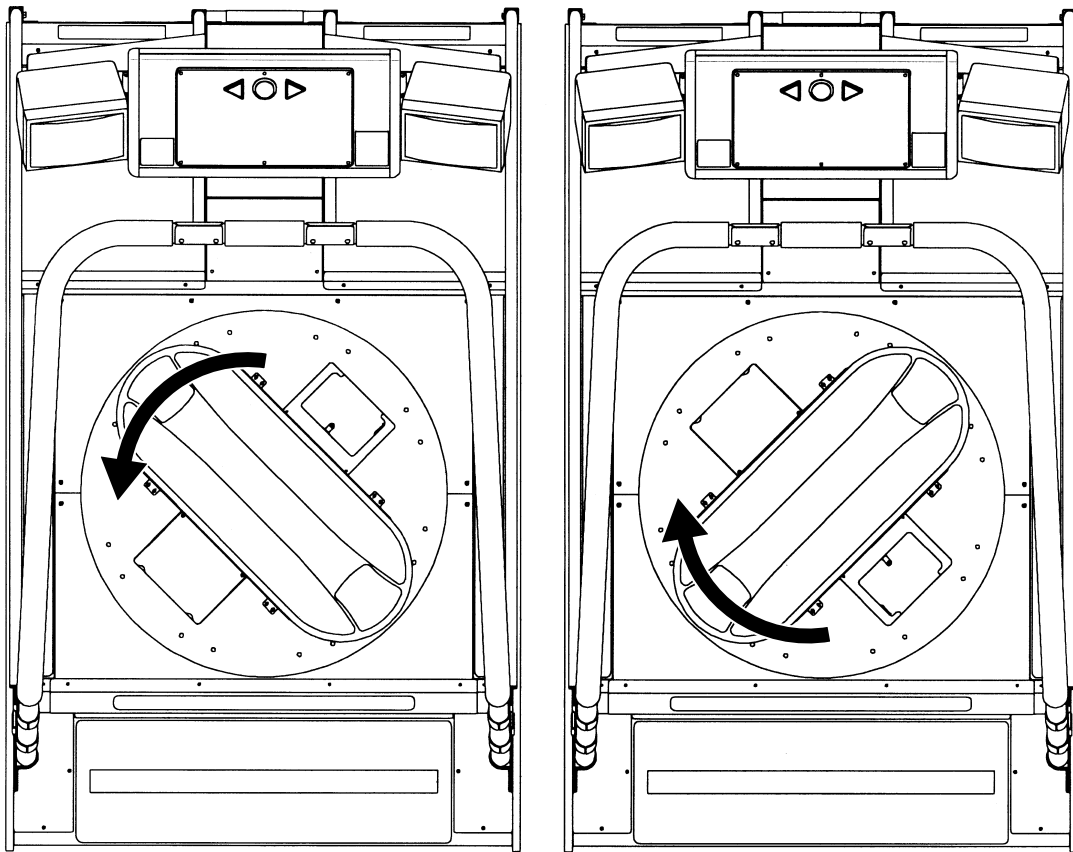

FIG. 10.3 b

- ⑫ Pour approximately 0.8 g of grease during one reciprocating motion of fully opening and closing the lever. Thus, pour a total of 8 g of grease during eight reciprocating lever motions.
- ⑬ Turn the Skateboard fully to the opposite end, and secure it there.
- ⑭ Pour a total of 8 g of grease during ten reciprocating lever motions.
- ⑮ Turn the Skateboard clockwise and counterclockwise several times to allow grease to reach every part of the swing bearing.

Because the grease in the Lubricant Tube will be used for the next greasing work, store it in the tube. Lock the chain for storage.

At time of the next greasing work, the grease in the nozzle will have been altered in quality because it will have been exposed to the outside air. Move the lever between the opposite ends twice or three times, and drain the grease from the nozzle. Then insert it into the nipple.

Greasing the Volume Control Mechanism Assembly

Grease the gear mesh portion of the Volume Control Mechanism Assembly and the crank sliding portion once every three months. For this purpose, use spray grease Grease Mate (Part No. 090-0066).

Make the Volume Control Mechanism Assembly seen externally, according to the instructions in Sections 10-1 and -2.

With an extension tube installed to the outlet of the spray grease, apply it to the gear mesh portion and the crank mechanism sliding portion. The gears of the YAW-direction Volume Control Mechanism Assembly are of two-step type. Apply the grease also to the gear mesh portion at the lower step.



PHOTO 10. 3 j
ROLL-Direction Volume Control Mechanism Assembly



PHOTO 10. 3 k
YAW-Direction Volume Control Mechanism Assembly

Greasing the Pinion Gears Mesh Portion

The pinion gears are used to lock the Skateboard.

Grease the pinion gears mesh portion once every three months. For this purpose, use spray grease Grease Mate (Part No. 090-0066).

To perform the greasing, keep the ROLL-Direction Volume Control Mechanism Assembly seen externally. (See Section 10-1.)

With an extension tube installed to the outlet of the spray grease, apply it to the gear mesh portion of the gears.

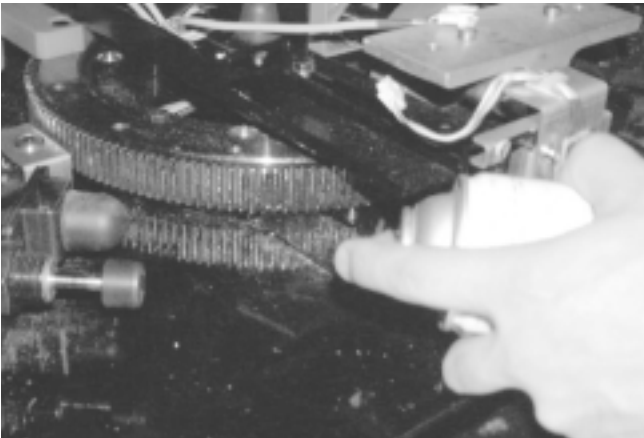
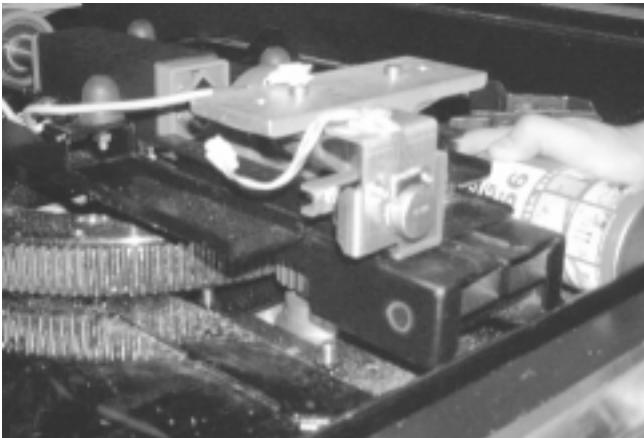

PHOTO 10. 3 l Pinion Gear

In the photograph, as a matter of convenience the turn table has been removed to allow the pinion gears to be seen externally. Actually, the greasing can be performed without removing the gears.

10 - 4 REPLACING THE ACCIDENT AVOIDANCE SYSTEM



If the hazard preventive parts have any irregularity, be sure to replace the part(s) immediately. Operating with the part(s) as is damaged or omitted can cause injury.

If the bellows under the Skateboard broken, replace them immediately. The following work requires a Phillips screwdriver for M4 screws and a socket wrench (or spanner) for M8 hexagon bolts.

- ① Turn off power.
- ② Remove the 3 screws from each of the 2 end and 2 side bellows sashes securing the bellows to the Skateboard.



SCREW (3 each), black
M4 X 12, w/flat & spring washers



PHOTO 10. 4 a

END BELLOWS SASHE

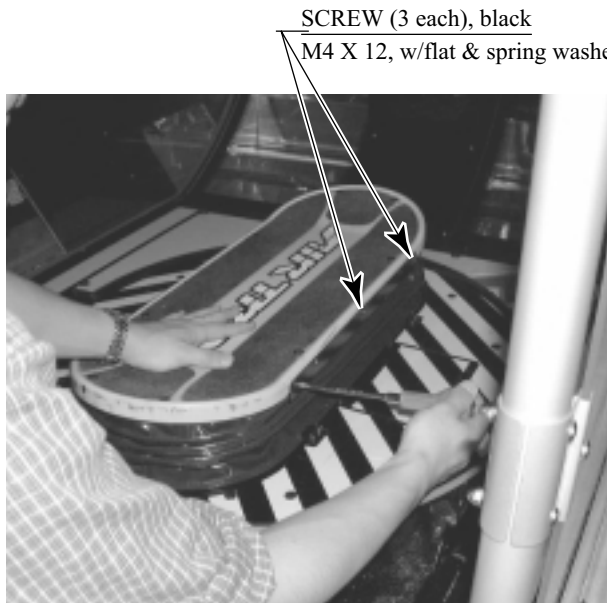

SCREW (3 each), black
M4 X 12, w/flat & spring washers



SIDE BELLOWS SASHE

PHOTO 10. 4 b

③ Release a total of 6 hooks (3 hooks at each side) and lower the bellows.

④ Pull out the 2 connectors. Release all the cord clamps securing the wire of the connector that was pulled out.

Disconnect the connector.



PHOTO 10. 4 c

⑤ Remove the 4 hexagon bolts securing the ASSY Skateboard.

HEXAGON BOLT (4)
M8 X 16, w/flat & spring washers

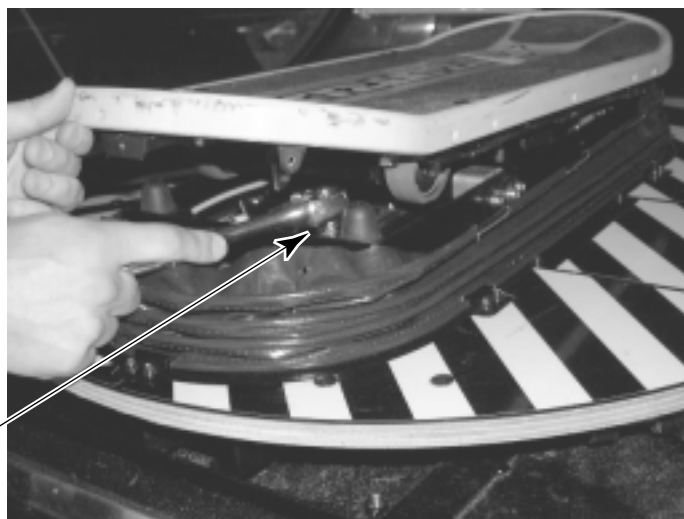

PHOTO 10. 4 d

HEXAGON BOLT (4)
M8 X 16, w/flat & spring washers

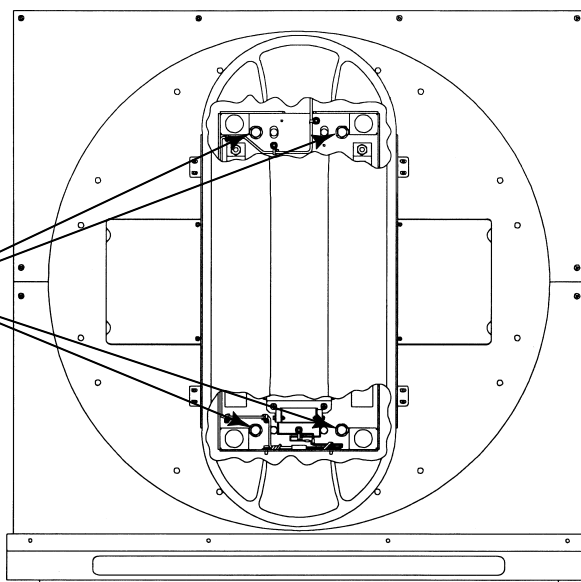

FIG. 10. 4

- ⑥ Remove the ASSY Skateboard.
At this time, take care not to
damage the wiring.

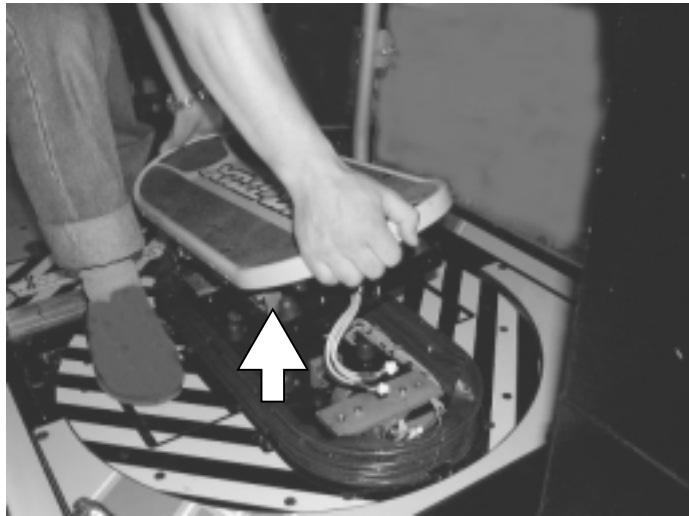
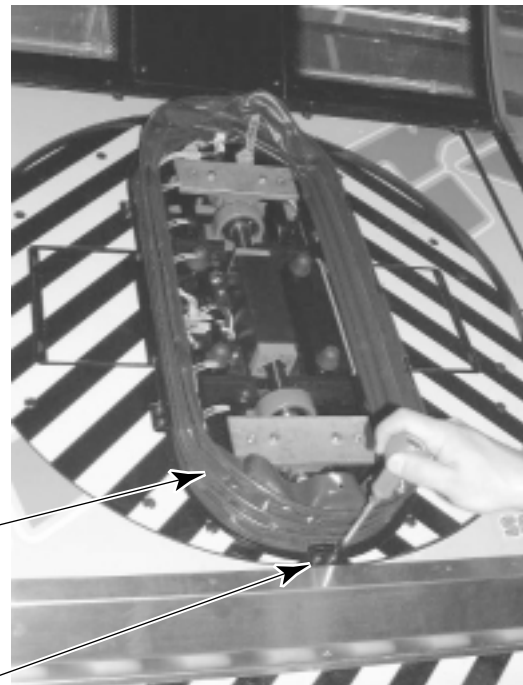
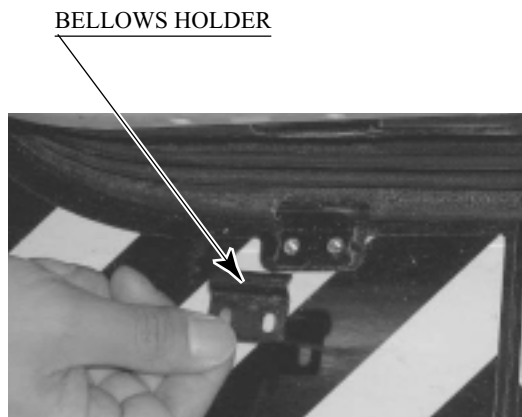

PHOTO 10. 4 e

- ⑦ Remove the 6 Bellows Holder securing the bottom of the bellows. Remove the 2 screws from
each of the holders.
- ⑧ Replace the bellows.



BELLOWS
ATR-3102

SCREW (2 each), black
M4 X 12, w/flat & spring washers

PHOTO 10. 4 f

11. PROJECTOR



Since the Projector has been adjusted at the time of shipment, avoid making further adjustments without good reason.



The Projector is subject to color deviation due to Convergence deviation caused by the geomagnetism at the installation location and peripheral magnetic field. After the installation of machine, and before commencing operation, check for Convergence deviation and if deviated, make adjustments.

Projector adjustments are stored. Due to distortion or color deviation in the TEST mode, if an adjustment is necessary, use the Remote Control to make adjustments. There are two Projector Makers (Toshiba and Mitsubishi) and the adjustment method varies depending on the specific maker.

11 - 1 CLEANING THE SCREEN



Since the Projector screen is susceptible to damage, pay careful attention to its handling. When cleaning, refrain from using water or volatile chemicals.

When the screen surface becomes dirty with dust, etc., clean it by using a soft cloth such as gauze. When water, and volatile chemicals such as benzene, thinner, etc., spill on the screen surface, it may be subject to damage, therefore, do not use them. Also, since the surfaces are susceptible to damage, refrain from rubbing them with a hard material or using a duster.

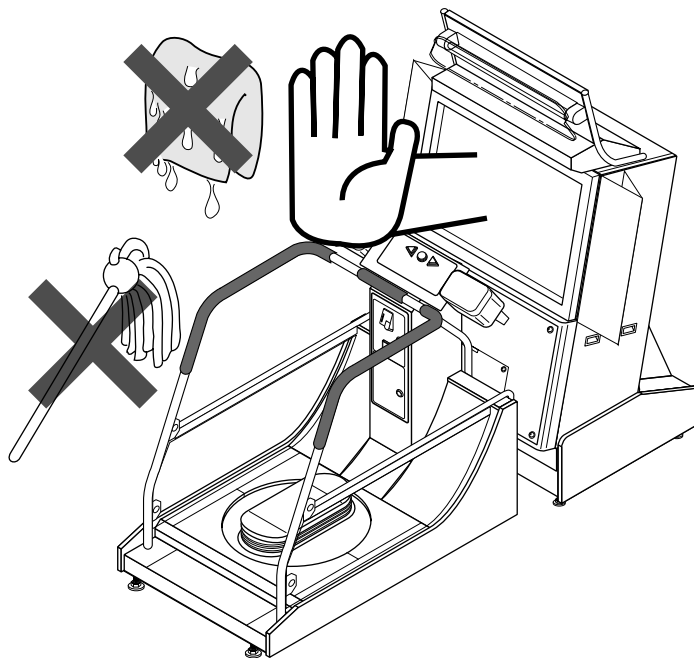

FIG. 11. 1

11 - 2 ADJUSTMENT OF TOSHIBA PROJECTOR

SETTING THE INTERFACE



In this product, set to INPUT LEVEL: 0.7V and IMPEDANCE: 75Ω. Failure to observe this can cause CRT membrane to burn or Shutdown device to function resulting in power off.

The Projector's Connector Panel contains the Interface setting SW.

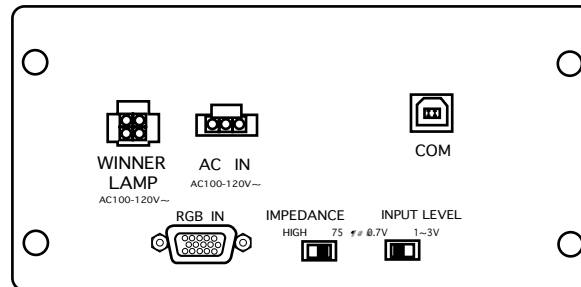

REMOTE CONTROL BUTTONS

When adjusting the Projector, direct the Remote Control's light emitting portion towards the Projector Screen.

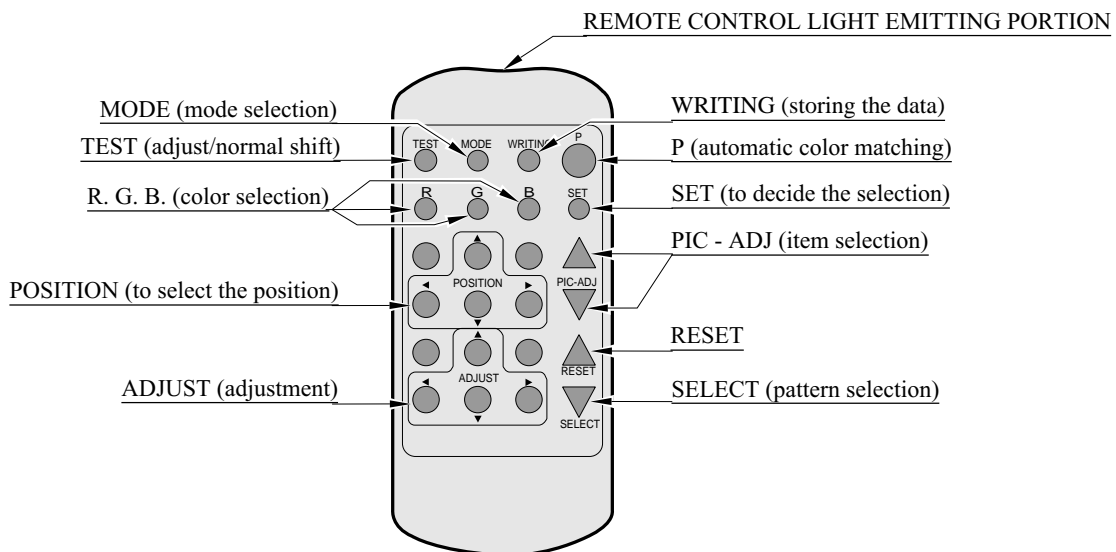

AUTOMATIC COLOR MATCHING

The Projector may be subject to color deviations affected by earth magnetism, the building steel frames, etc. When the Projector is initially installed or the Projector's installation position is changed, have the color matching performed automatically.

- ① Keep pressing the P button (red) for approximately 3 seconds to have the ensuing movements performed automatically.

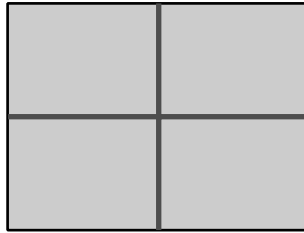
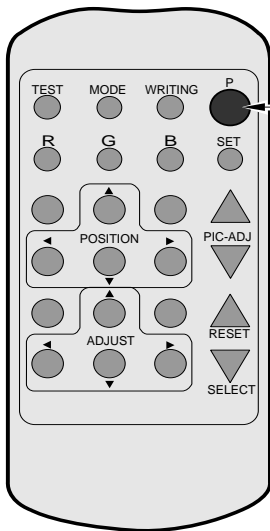

The Projector will shift to the color deviation correction mode from the game mode, with the green cross pattern appearing on the screen.

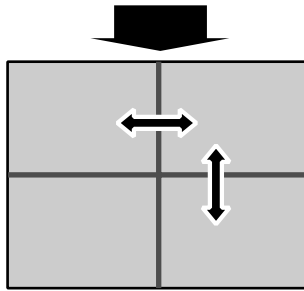

The cross pattern moves up/down and right/left to start the movement of searching the correct screen position and inclination.

When the green cross pattern movements are finished, similar detection is performed sequentially in order of red and then blue cross movements. After detecting by green, red and blue cross movements, the game mode returns with the color deviation status being corrected.

- Although very rarely, the TRY AGAIN error display in red may appear. At this time, press the P button (red) for approximately 3 seconds. Even after the above operation is repeated, if the error condition still exists, then the display shifts to PLEASE ADJ. In this case, the auto color matching function can not be used. Contact the place of contact herein stated or where the product was purchased from.
- If the automatic color matching indicates an error, color matching can manually be performed. Refer to CONVERGENCE ADJUSTMENT (manual color matching).

ADJUSTING THE ON-SCREEN CONTRAST

Although the on-screen picture quality has been adjusted at the time of shipment from the factory, the on-screen contrast can be readjusted if desired. When the Game Board is replaced, readjustment may be necessary. Changing the CONTRAST causes the light and shade of the on-screen images to be changed.

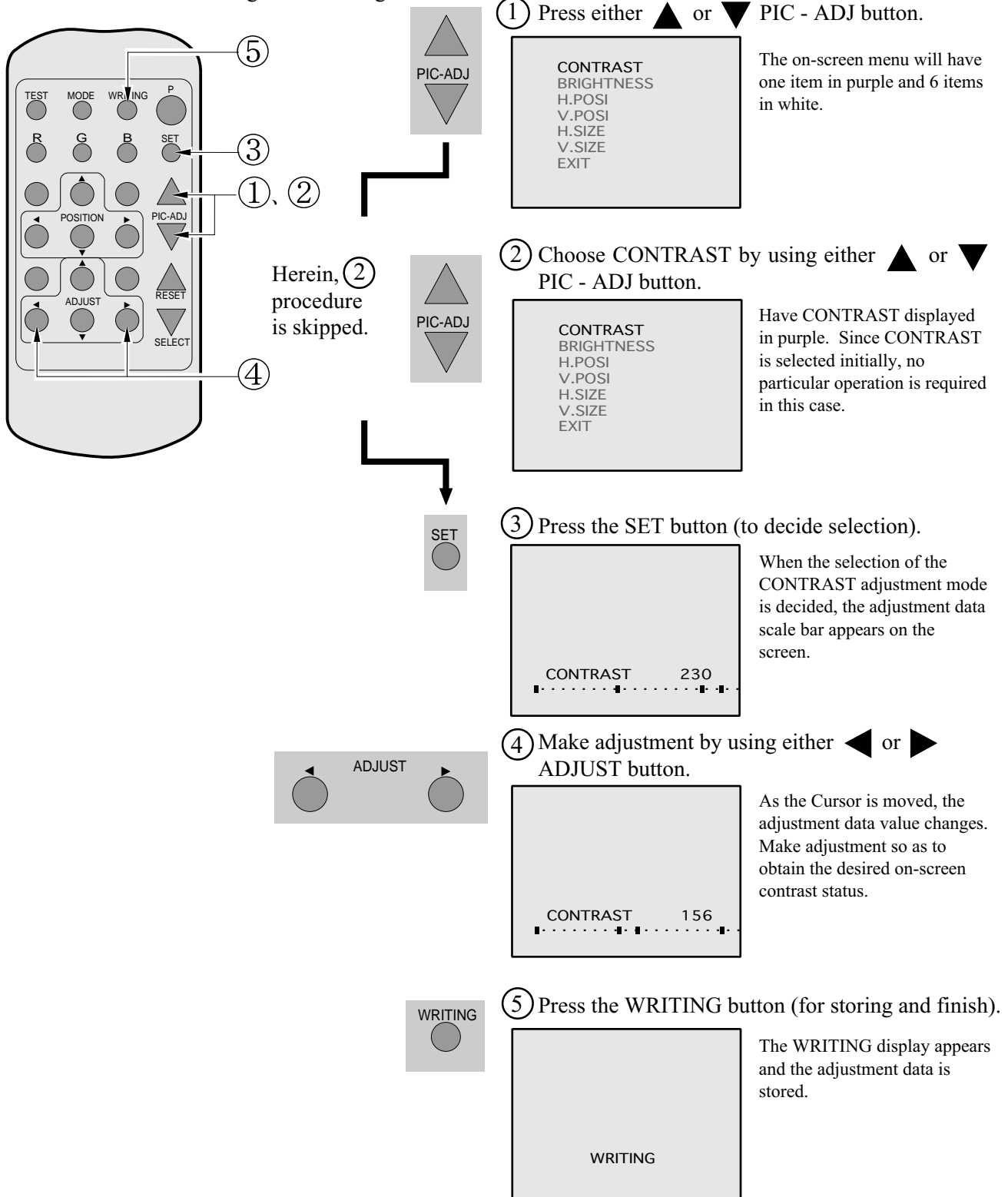

- When discontinuing the adjustment, choose EXIT from the menu at the stage of procedure ② and press the SET button.
- To continue adjusting other menu items, repeat procedure ② ~ ④.
- Unless the adjustment data is stored, the data in the adjusted status will be erased at the time the power is turned off and the pre-adjustment status will remain when the power is turned on next time.

ADJUSTING THE SCREEN BRIGHTNESS

Although the on-screen picture quality has been adjusted at the time of shipment from the factory, readjustment can be made if desired. When the Game Board is replaced, readjustment may be necessary. Changing the BRIGHTNESS causes the brightness of the on-screen images of black portions to be changed.

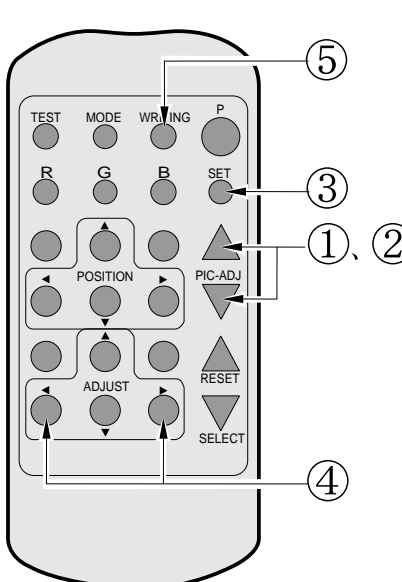

① Press either ▲ or ▼ PIC - ADJ button.

The on-screen menu will have one item in purple and 6 items in white.

```

CONTRAST
BRIGHTNESS
H.POSI
V.POSI
H.SIZE
V.SIZE
EXIT
    
```

② Choose BRIGHTNESS by using either ▲ or ▼ PIC - ADJ button.

Have the BRIGHTNESS displayed in purple.

```

CONTRAST
BRIGHTNESS
H.POSI
V.POSI
H.SIZE
V.SIZE
EXIT
    
```

③ Press the SET button (to decide selection).

When the selection of the BRIGHTNESS adjustment mode is decided, the adjustment data scale bar appears on the screen.

```

BRIGHTNESS 128
┌───────────┴───────────┐
    
```

④ Make adjustment by using either ◀ or ▶ ADJUST button.

As the Cursor is moved, the adjustment data value changes. Make adjustment so as to obtain the desired on-screen brightness status.

```

BRIGHTNESS 156
┌───────────┴───────────┐
    
```

⑤ Press the WRITING button (for storing and finish).

The WRITING display appears and the adjustment data is stored.

```

WRITING
    
```

- When discontinuing the adjustment, choose EXIT from the menu at the stage of procedure ② and press the SET button.
- To continue adjusting other menu items, repeat procedure ② ~ ④.
- Unless the adjustment data is stored, the data in the adjusted status will be erased at the time the power is turned off and the pre-adjustment status will remain when the power is turned on next time.

ADJUSTING THE ON-SCREEN DISPLAY POSITION

Although the on-screen display position (H. POSI, V. POSI) has been adjusted at the time of shipment from the factory, readjustment can be made if desired. When the Game Board is replaced, readjustments may be necessary.

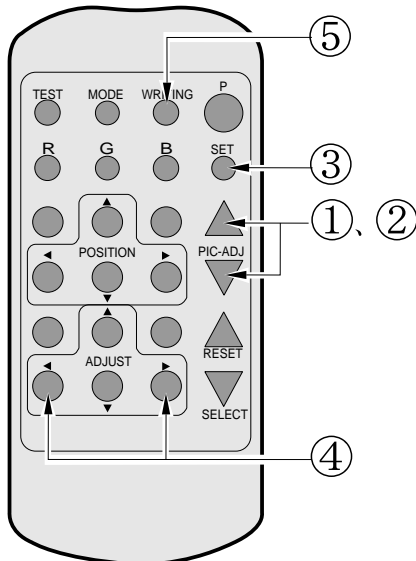

① Press either ▲ or ▼ PIC - ADJ button.

The on-screen menu will have one item in purple and 6 items in white.

```

CONTRAST
BRIGHTNESS
H.POSI
V.POSI
H.SIZE
V.SIZE
EXIT
    
```

② Choose H. POSI or V. POSI by using either ▲ or ▼ PIC ADJ button.

Have the H. POSI or V. POSI displayed in purple. The Figure shows the status in which H. POSI is selected.

```

CONTRAST
BRIGHTNESS
H.POSI
V.POSI
H.SIZE
V.SIZE
EXIT
    
```

③ Press the SET button (to decide selection).

When the selection of the H. POSI or V. POSI is decided, the adjustment data scale bar appears on the screen.

```

H.POSI 128
┌-----┴-----┐
└-----┬-----┘
    
```

④ Make adjustment by using either ◀ or ▶ ADJUST button.

As the Cursor is moved, the adjustment data value changes. Make adjustment so as to obtain the desired on-screen position status.

```

H.POSI 156
┌-----┴-----┐
└-----┬-----┘
    
```

⑤ Press the WRITING button (for storing and finish).

The WRITING display appears and the adjustment data is stored.

```

WRITING
    
```

When making adjustments in vertical directions, also use either ▲ or ▼ ADJUST button.

- When discontinuing the adjustment, choose EXIT from the menu at the stage of procedure ② and press the SET button.
- To continue adjusting other menu items, repeat procedure ② ~ ④.
- Unless the adjustment data is stored, the data in the adjusted status will be erased at the time the power is turned off and the pre-adjustment status will remain when the power is turned on next time.

ADJUSTING THE SCREEN SIZE

Although the on-screen size (H. SIZE, V. SIZE) has been adjusted at the time of shipment from the factory, readjustment can be made if desired. When the Game Board is replaced, readjustments may be necessary.

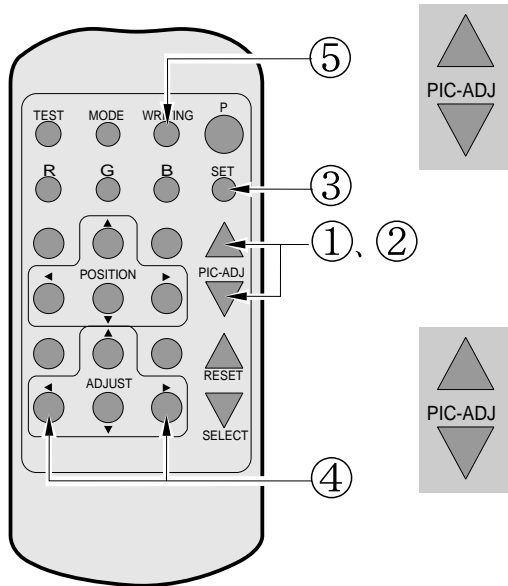

① Press either ▲ or ▼ PIC - ADJ button.



The on-screen menu will have one item in purple and 6 items in white.

② Choose H. SIZE or V. SIZE by using either ▲ or ▼ PIC - ADJ button.



Have the H. SIZE or V. SIZE displayed in purple. The Figure shows the status in which H. SIZE is selected.

③ Press the SET button (to decide selection).

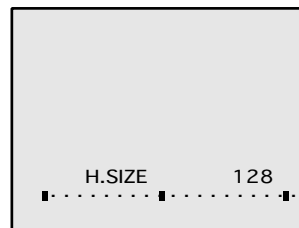

When the selection of the H. SIZE or V. SIZE adjustment mode is decided, the adjustment data scale bar appears on the screen.

④ Make adjustment by using either ◀ or ▶ ADJUST button.

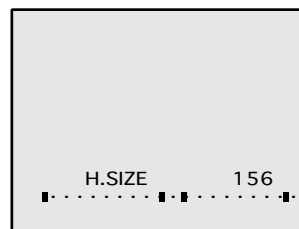

As the Cursor is moved, the adjustment data value changes. Make adjustment so as to obtain the desired on-screen position status.

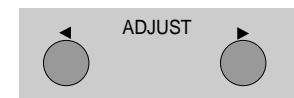

When making adjustments in vertical directions, also use either ◀ or ▶ button.

⑤ Press the WRITING button (for storing and finish).

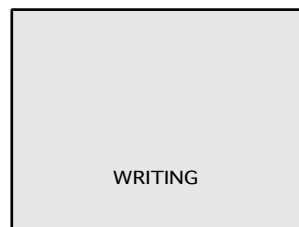

The WRITING display appears and the adjustment data is stored.

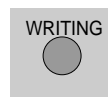

- When discontinuing the adjustment, choose EXIT from the menu at the stage of procedure ② and press the SET button.
- To continue adjusting other menu items, repeat procedure ② ~ ④.
- Unless the adjustment data is stored, the data in the adjusted status will be erased at the time the power is turned off and the pre-adjustment status will remain when the power is turned on next time.

CONVERGENCE ADJUSTMENT (manual color matching)



To avoid circuitry malfunctioning due to electrical load increase, never utilize CONVERGENCE ADJUSTMENT (Line Convergence Adjustment in particular) for adjusting screen size changes.

There is no means to restore the Convergence Adjustment data once stored, to its original state. To avoid changing the screen size by erroneously using convergence adjustment, do not perform the green Line Convergence Adjustment.

As such, be sure to perform the adjustment work from this page onward by the Technical staff and the location's Maintenance Personnel who are well versed in such adjustment work. In the Static Convergence Adjustments, if satisfactory adjustments can not be performed, do not make another convergence adjustments inadvertently. Contact the office herein stated or where the product was purchased from.



- To avoid making the adjustment work ineffective, do not press the RESET button during adjustment.
- To discontinue adjustment work, keep pressing the TEST button for approximately 3 seconds at the stage before storing the adjustment data by pressing the WRITING button.
- Should the screen be abnormally disturbed by noise due to static electricity, etc., turn the power off without storing the adjustment data.
- Pressing the ▲ or ▼ PIC - ADJ button in the Convergence Adjustment mode status will display the Adjustment Menu shown right. Do not utilize this Adjustment Menu as this is the one applied at the factory.

Adjusting this menu causes the Customer's adjustment range to be deviated.

Should the menu shown right be displayed by mistake, first choose EXIT by using either ▲ or ▼ PIC - ADJ button and then press the SET button.

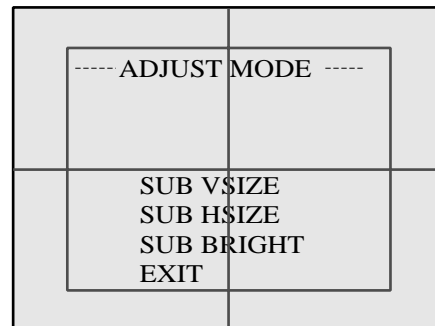

Adjustment menu used in the factory.

STATIC CONVERGENCE ADJUSTMENT

In the static convergence adjustment, each of red and blue images is comprehensively moved to and superimposed on the green color. If automatic color matching function is not sufficiently satisfactory, perform this adjustment. Be sure to perform automatic color matching before starting the above adjustment.

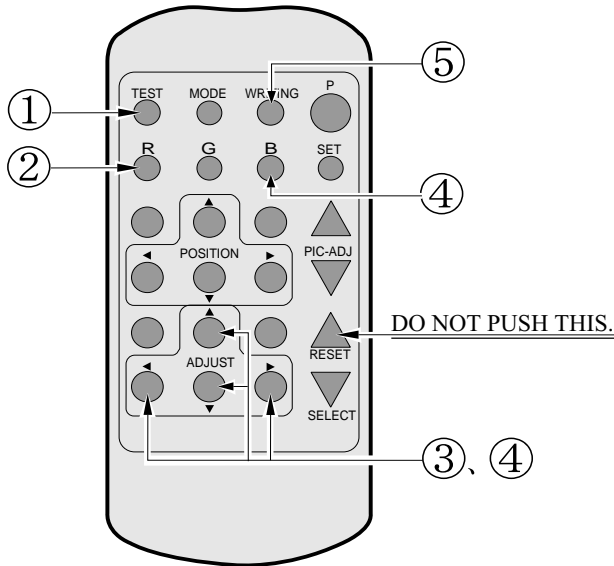

When either of ② ④ COLOR SELECT buttons (R, B) is pressed, if the color desired to be adjusted disappears, press that particular button again. For example, if the red color needs to be adjusted again at the stage of ④, the R button need to be pressed twice.

- ① Keep pressing the TEST button for approximately 3 seconds.

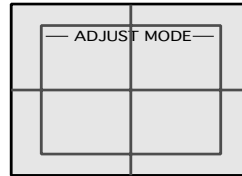

The screen will change to ADJUST mode from the Game mode to cause the green test pattern to be displayed on the screen.

- ② Press the R button to have the red adjustment mode.

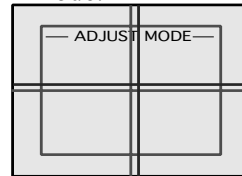

The red test pattern is added to the display. The frame color turns red and this signifies the red adjustment mode.

- ③ Make adjustment by using the ▲ ▼ ◀ ▶ ADJUST buttons.

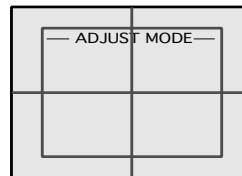

Make adjustment so as to have red superimposed on green. When red is superimposed on green, the color becomes yellow.

- ④ Press the B button to have the blue adjustment mode.

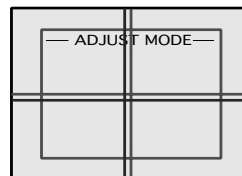

Similarly as in the case of red, adjust the blue color. When green, red, and blue are superimposed, the color becomes white.

- ⑤ Press the WRITING button (for storing and finish).

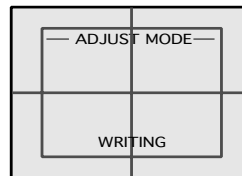

The WRITING display appears and the adjustment data is stored. After the data is stored, the Game mode returns.

POINT CONVERGENCE ADJUSTMENT

In the POINT CONVERGENCE adjustment, each of red, green and blue images is partially moved for color matching. The adjustment may be necessary when the Game Board is replaced or changed, or screen size is changed. Be sure to perform automatic color matching before starting the adjustment.

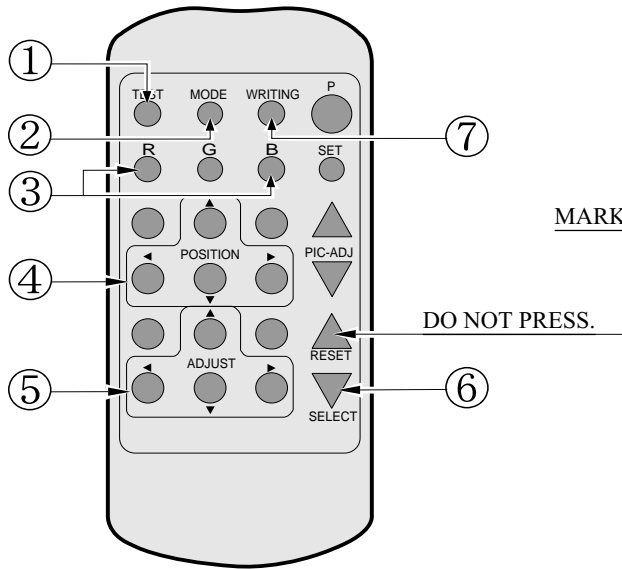

Note 1 When the MODE button is repeatedly pressed, the adjustment modes will circulate as follows:

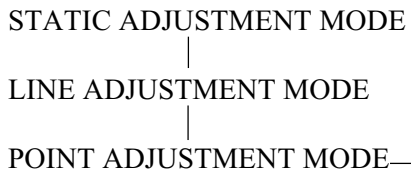

Note 2 When either of the COLOR SELECT buttons (R, B) is pressed, if the desired color to be adjusted disappears, press that particular button again.

Note 3 By repeatedly pressing the SELECT button, only the Projector's TEST pattern screen and the screen superimposing the Game Board Test pattern can be alternately displayed.

① Keep pressing the TEST button for approximately 3 seconds.

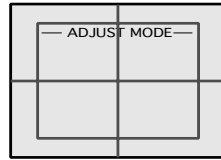

The screen changes to ADJUST mode from the Game mode and displays the green test pattern.

② Press the MODE button twice to have the POINT ADJUSTMENT mode. Note 1

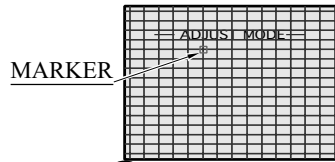

The crosshatch test pattern appears and the MARKER indicating the adjustment point is displayed.

③ Using either R or B button, select the desired color to be adjusted. Note 2 By using the G button, the green color can also be selected.

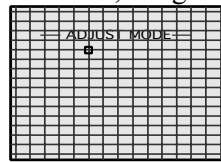

The selected color is displayed by superimposing on green. The MARKER will be in the color selected.

④ By using the ▲ ▼ ◀ ▶ ADJUST buttons, move the MARKER to the position to be adjusted.

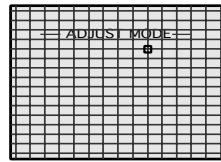

The MARKER moves in the direction of the button's arrow. However, the movable point is predetermined.

⑤ Make adjustment by using the ▲ ▼ ◀ ▶ ADJUST buttons.

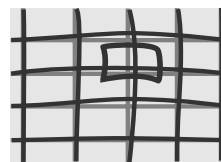

Although the direct vicinity of the MARKER's center moves most conspicuously, make adjustment by paying attention to the periphery area also. Shown left is the magnified MARKER periphery.

⑥ Press the SELECT button as necessary to superimpose Game Board images. Note 3

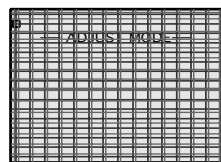

If the test pattern is not displayed in the periphery of the screen, adjustments can be made by pressing the SELECT button to superimpose the test pattern and the Game Board's CRT test screen.

⑦ Press the WRITING button (for storing and finish).

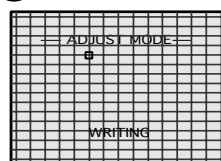

WRITING is displayed and the adjustment data is stored. After the data is stored, the Game Board screen returns.

LINE CONVERGENCE ADJUSTMENT

In the LINE CONVERGENCE ADJUSTMENT, the adjustment point of the column line (vertical) or row line (horizontal) is comprehensively moved for color matching. It is convenient to utilize this adjustment when the color of the column line or row line is uniformly deviated.

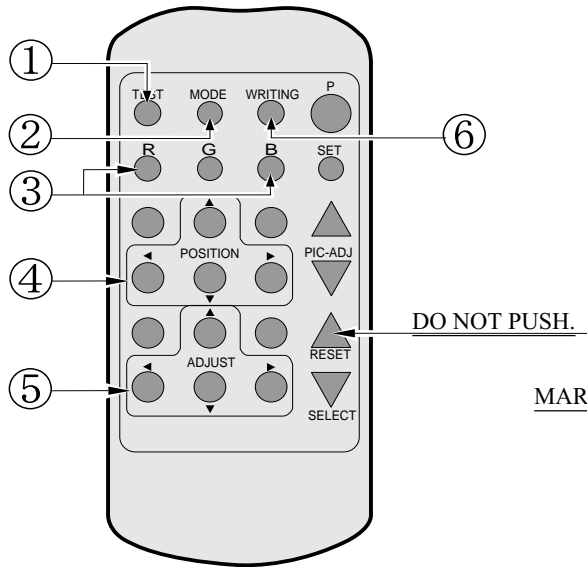

Note 1 When the MODE button is repeatedly pressed, the adjustment modes will circulate as follows:

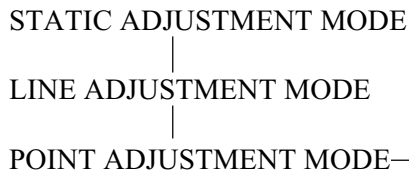

Note 2 When either of the COLOR SELECT buttons (R, B) is pressed, if the desired color to be adjusted disappears, press that particular button again.

① Keep pressing the TEST button for approximately 3 seconds.

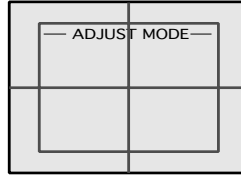

The screen changes to ADJUST mode from the Game Board mode and displays the green test pattern.

② Press the MODE button once to have the POINT ADJUSTMENT mode. Note 1

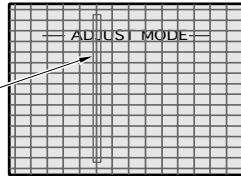

The crosshatch test pattern appears and the vertically long MARKER is shown.

③ Using either R or B button, select the desired color to be adjusted. Note 2 Although the green color can also be selected by using the G button, to avoid the screen size change adjustment, do not choose green.

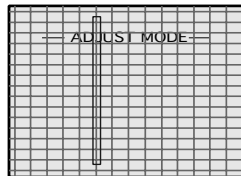

The selected color is displayed by superimposing on green. The MARKER will be in the color selected.

④ By using the ▲ ▼ ◀ ▶ POSITION buttons, move the MARKER to the position to be adjusted.

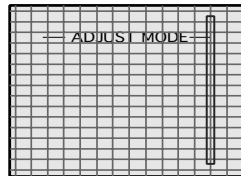

Use the ◀ ▶ buttons to select the column line, and the MARKER moves in the right/left direction. However, the movable range is predetermined.

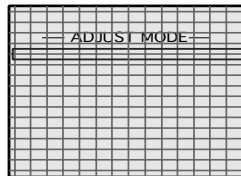

Use the ▲ ▼ buttons to select the row line and the MARKER moves in the up/down direction. However, the movable range is predetermined.

⑤ Make adjustment by using the ▲ ▼ ◀ ▶ ADJUST buttons.

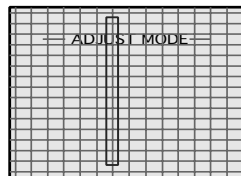

The selected column line or row line (shown left is the column line) can be moved in the desired up/down or right/left directions as applicable.

⑥ Press the WRITING button (for storing and finish).

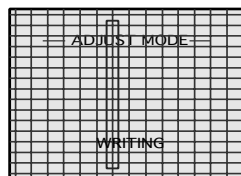

WRITING is displayed and the adjustment data is stored. After the data is stored, the Game Board screen returns.



- For the operation of Remote Control, use only the Keys of R/B, ▲ (UP shift), ◁ (LEFT shift), ▼ (DOWN shift), ▷ (RIGHT shift), TEST, -, +, and PICTURE. Do not press keys other than those explained in this manual.
- When operating the Remote Control, have it point the screen.

The Projector has DYNAMIC CONVERGENCE adjustment functions. This manual does not refer to the functions as the adjustment of DYNAMIC CONVERGENCE is very troublesome and in addition, visual effects are negligible.

Very rarely, you cannot solve a color-shift problem even with the adjustment procedure described below. If this is the case, contact where you have procured the projector and ask for further information on the adjustment method.

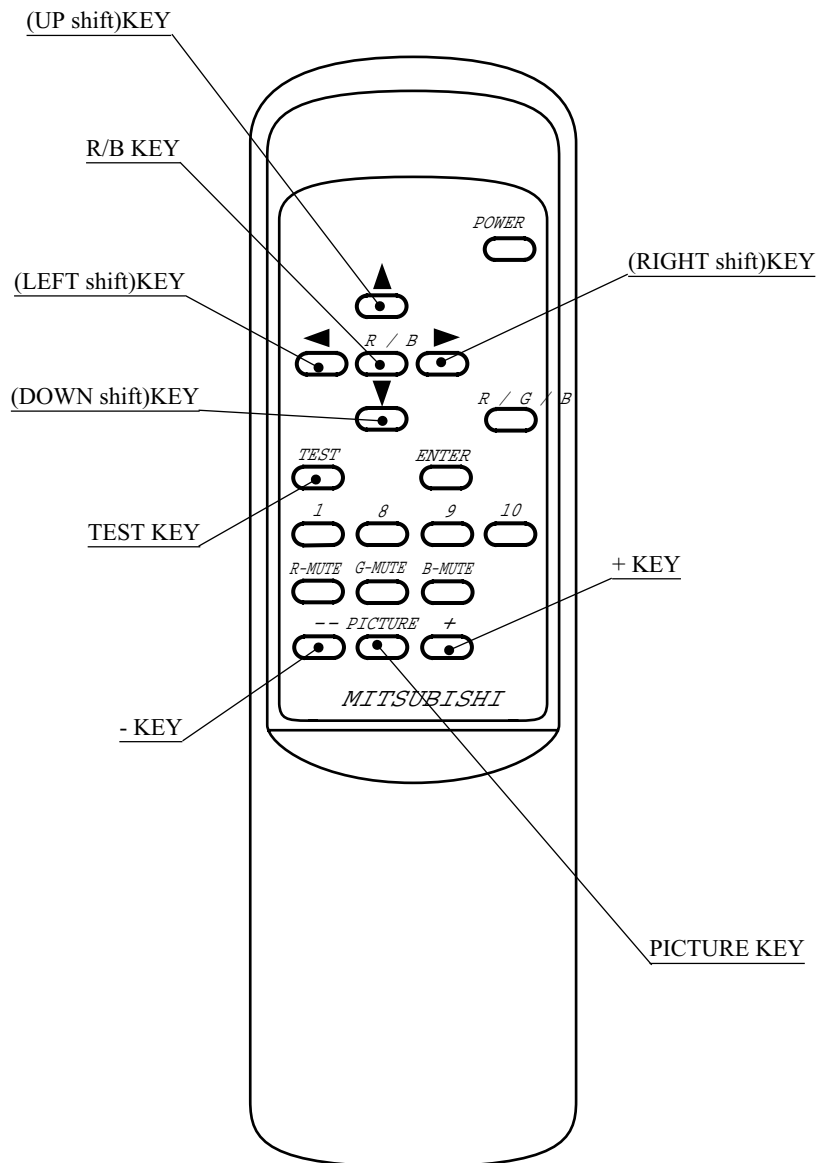

- POWER KEY This does not have power ON/OFF function.
Does not function even if it is pressed.
- R/B KEY Used to select "R" for red adjustment or "B" for blue adjustment in the STATIC CONVERGENCE ADJUSTMENT mode.
- ▲ (UP shift) KEY Used to move the test cross upward in the STATIC CONVERGENCE ADJUSTMENT mode.
- ◁ (LEFT shift) KEY Used to move the test cross to the left in the STATIC CONVERGENCE ADJUSTMENT mode.
- ▼ (DOWN shift) Used to move the test cross downward in the STATIC CONVERGENCE ADJUSTMENT mode.
- ▷ (RIGHT shift) KEY Used to move the test cross to the right in the STATIC CONVERGENCE ADJUSTMENT mode.
- TEST KEY This is the ON/OFF key in the STATIC CONVERGENCE ADJUSTMENT mode. In the ON status of this key, the test cross pattern appears in the approximately on-screen center.
- ENTER KEY Used for DYNAMIC CONVERGENCE.
- KEY Used to decrease the adjustment data in the adjustment mode of CONTRAST, BRIGHTNESS, HORIZONTAL/VERTICAL POSITIONS and WIDTH.
- + KEY Used to increase the adjustment data in the adjustment mode of CONTRAST, BRIGHTNESS, HORIZONTAL/VERTICAL POSITIONS and WIDTH.
- PICTURE KEY Used for the ADJUSTMENT mode of CONTRAST, BRIGHTNESS, HORIZONTAL/VERTICAL POSITIONS and WIDTH.
Every time this key is pressed, the ADJUSTMENT mode proceeds as follows:

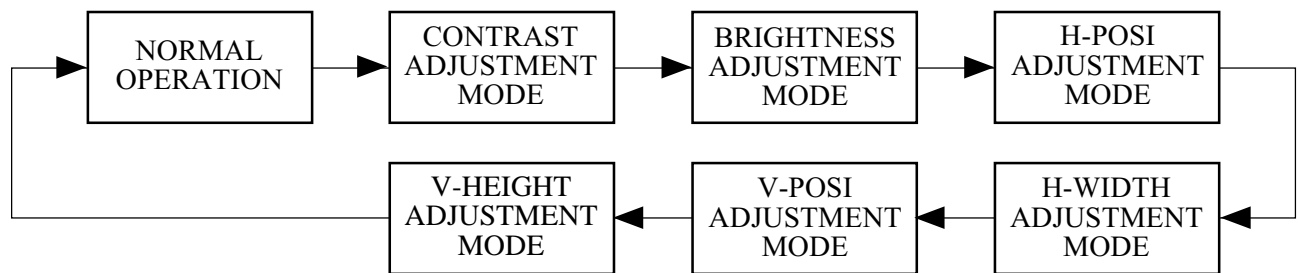

EXPLANATIONS OF ADJUSTMENT MODES

- CONTRAST Used to vary image contrast. Use + and - keys to adjust.
- BRIGHTNESS Used to change image brightness. Use + and - keys to adjust.
- H-POSI Used to move the image position in the horizontal direction. Use + and - keys to adjust.
- H-WIDTH Used to change the horizontal width of image. Use + and - keys to adjust.
- V-POSI Used to move the image position in the vertical direction. Use + and - keys to adjust.
- V-HEIGHT Used to change the vertical width of image. Use + and - keys to adjust.

STATIC CONVERGENCE ADJUSTMENT

Press the TEST KEY to change the screen to Red Line Adjustment mode.

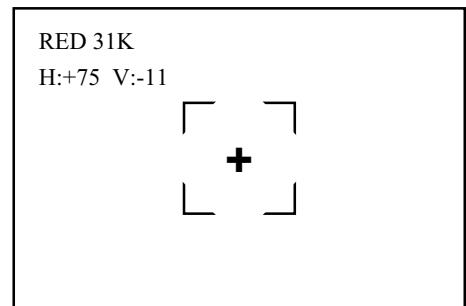

Superimpose the red line on the green line.
When the red line is superimposed on the green line, the green line turns to yellow or white.

To MOVE RED LINE:

- Use ◁ key to move it left.
- Use ▷ key to move it right.
- Use ▲ key to move it upward.
- Use ▼ key to move it downward.

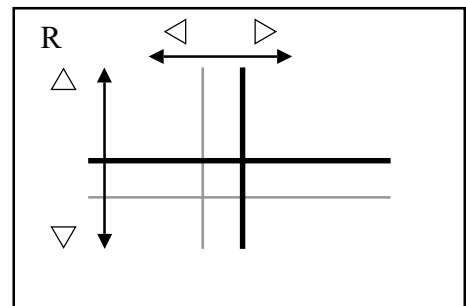

Press the R/B KEY.
Changes to the Blue Line Adjustment screen.
Every time the key is pressed, "from red to blue" and "from blue to red" are alternated.

SUPERIMPOSING BLUE LINE ON GREEN LINE:
Superimposing blue line on green line causes the green line to turn to white.

TO MOVE BLUE LINE:

- Use ◁ key to move it left.
- Use ▷ key to move it right.
- Use ▲ key to move it upward.
- Use ▼ key to move it downward.

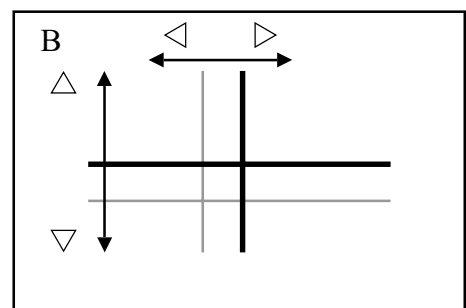

Press the TEST KEY.
Adjustment is finished.

AUTOMATIC CANCELLATION OF ADJUSTMENT MODE

In each adjustment mode, only in the case where an effective key input (variation of values and images) is not performed within the time limit indicated below, the adjustment mode is automatically cancelled and finished, shifting to on-screen normal images.

Approximately 6 seconds CONTRAST
 BRIGHTNESS
 H-POSI
 H-WIDTH
 V-POSI
 V-HEIGHT

Approximately 5 min. STATIC CONVERGENCE

12. COIN SELECTOR

HANDLING THE COIN JAM

If the coin is not rejected when the REJECT button is pressed, open the coin chute door and open the selector gate. After removing the jammed coin, put a normal coin in and check to see that the selector correctly functions.

CLEANING THE COIN SELECTOR



- Remove and clean smears by using a soft cloth dipped in water or diluted chemical detergent and then squeezed dry.
- Never apply machine oil, etc. to the Coin Selector.
- After cleaning the Coin Selector, insert a regular coin in the normal working status and ensure that the Selector correctly functions.

The coin selector should be cleaned once every 3 months. When cleaning, follow the procedure below:

- ① Turn the power for the machine OFF. Open the coin chute door.
- ② Open the gate and dust off by using a soft brush (made of wool, etc.).
- ③ Remove and clean smears by using a soft cloth dipped in water or diluted chemical detergent and then squeezed dry.
- ④ Remove the CRADLE.
When removing the retaining ring (E ring), be very careful so as not to bend the rotary shaft.
- ⑤ Remove stain from the rotary shaft and shaft receiving portions by wiping off with a soft cloth, etc.
- ⑥ After wiping off as per ④ above, further apply a dry cloth, etc. to cause the coin selector to dry completely.

COIN INSERTION TEST

Once every month, when performing the Coin SW Test, simultaneously check the following:

- Does the Coin Meter count satisfactorily?
- Does the coin drop into the Cashbox correctly?
- Is the coin rejected when inserted while keeping the Reject Button pressed down?

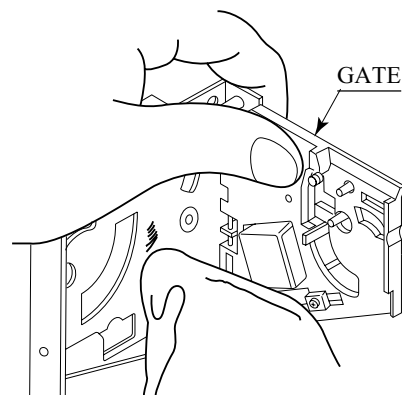

FIG. 12 a

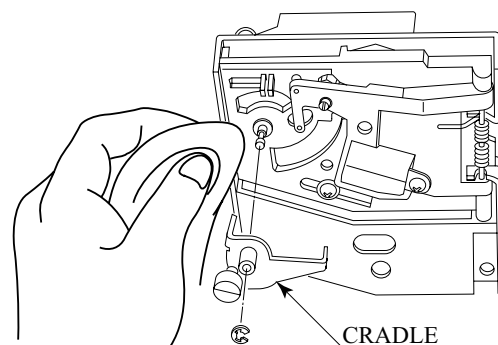

FIG. 12 b

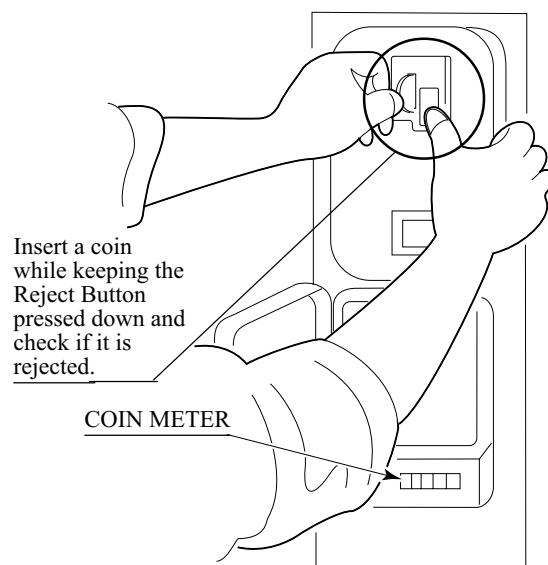

FIG. 12 c

13. REPLACING THE FLUORESCENT LAMP, AND LAMPS



WARNING!

- When performing work, be sure to turn power off. Working with power on can cause electric shock and short circuit hazards.
- The Fluorescent Lamp, when it gets hot, can cause burn. Be very careful when replacing the Fluorescent Lamp.
- Be sure to use lamps of the designated rating. Using lamps of undesignated rating can cause a fire or malfunctioning.



CAUTION!

- To perform work safely and securely, be sure to prepare a step which is in a secure and stable condition. Performing work without using the step can cause violent falling down accidents.
- Be careful when handling the plastic made parts. Failure to observe this may cause injury due to damage or fragments resulting from damage.

BILLBOARD FLUORESCENT LAMP

- ① Turn off power.
- ② Use a step for the following work. Using a short flat-tipped screwdriver, remove the 2 truss screws securing the FL Cover Plate.
- ③ Draw out the FL Cover Plate toward you.
- ④ Replace the fluorescent lamp.

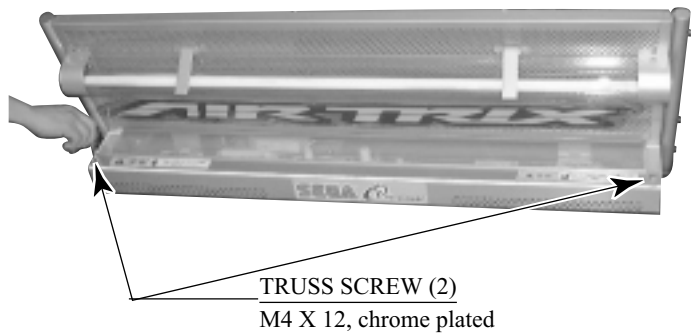

PHOTO 13 a

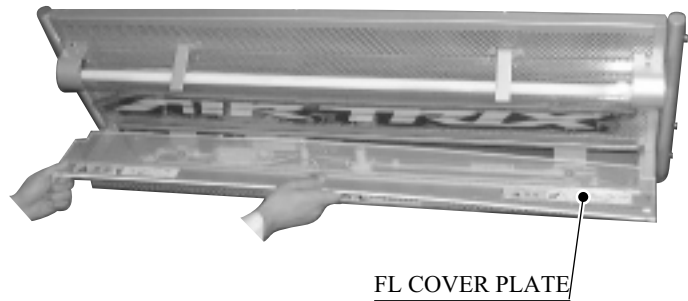
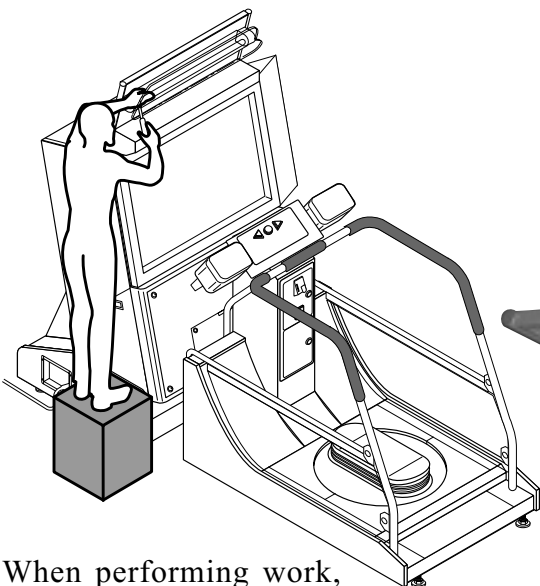

PHOTO 13 b



FLUORESCENT LAMP 32W:390-5251-32-01
GLOW LAMP:390-5638-5P

PHOTO 13 c



When performing work, prepare a step.

BILLBOARD SLIM TUBE

- ① Turn off power.
- ② Use a step for the following work.
Remove the 2 truss screws securing the Billboard Plate.



TRUSS SCREW (2)
M4 X 8, chrome plated

PHOTO 13 d

- ③ Remove the Billboard Plate by pulling it out upward.

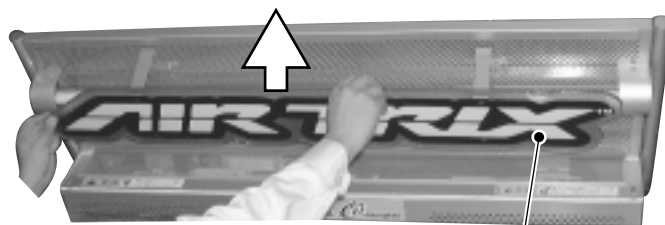

BILLBOARD PLATE

PHOTO 13 e

- ④ Remove either one of the left and right acryl holders.

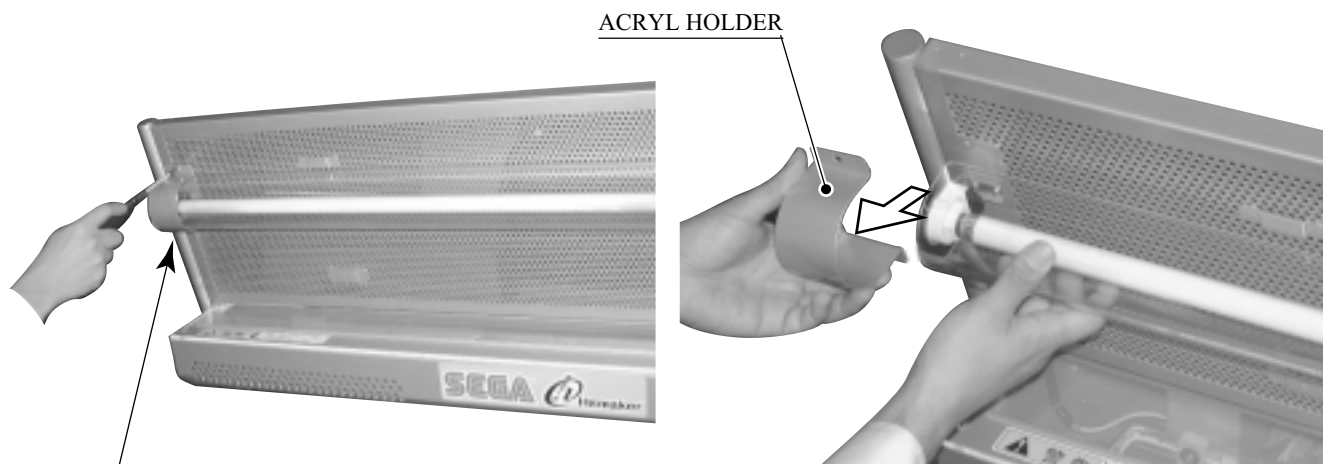

TRUSS SCREW (2)
M4 X 8, chrome plated

PHOTO 13 f

- ⑤ Remove the Slim Cover by pulling it out toward the side where the acryl holder was removed. The cover is plastic. Pay attention to that applying load carelessly to it may cause it to break.

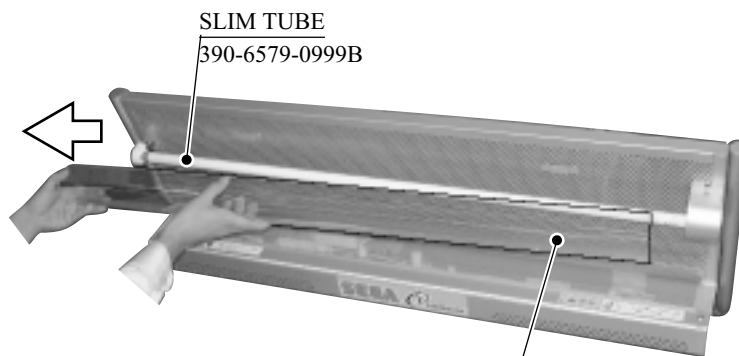

SLIM TUBE
390-6579-0999B

SLIM COVER

PHOTO 13 g

- ⑥ Replace the Slim Tube.

START BUTTON LAMP

- ① Turn off power.
- ② Remove the 6 truss screw securing the Switch Panel.

TRUSS SCREW (6)
M4 X 10, chrome plated

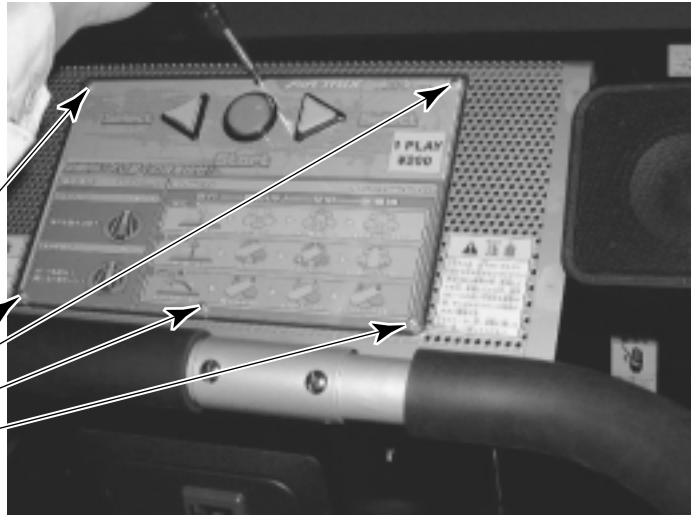

PHOTO 13 h

- ③ Remove the Switch Panel. The Switch Panel contains wiring connections. Remove this panel, taking care not to damage the wiring.

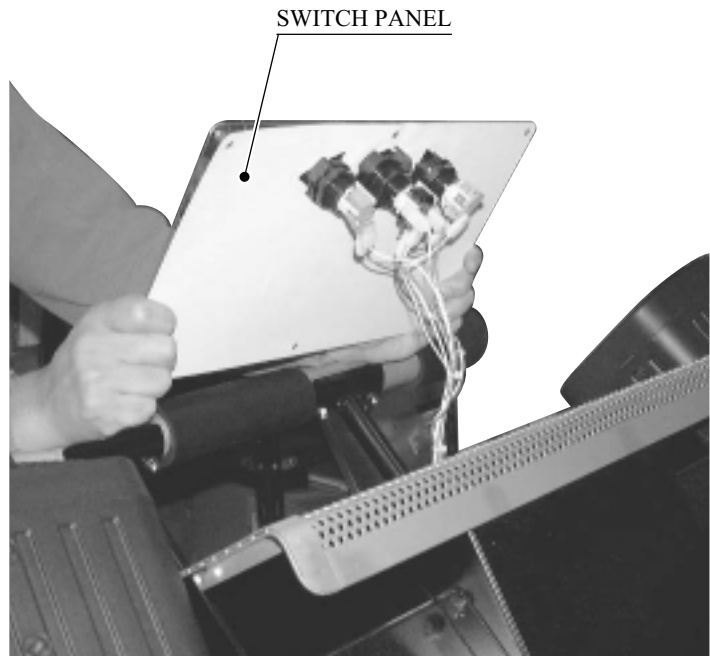

PHOTO 13 i

- ④ Hold both sides of the switch portion with fingers and pull out from the button's base portion. At this time, be careful so as not to damage the wiring connected to the switch.
- ⑤ The lamp is positioned at the end of the switch portion. Pull out the lamp straight without turning it.

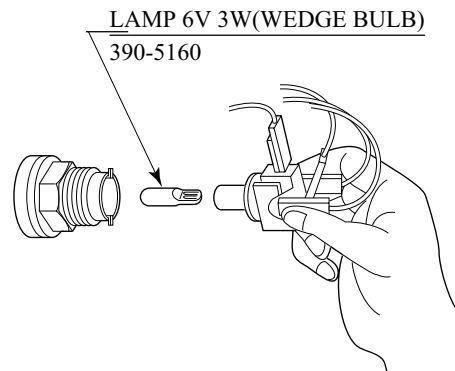

FIG. 13 b

Cold-Cathode Tubes of Rear Cabinet

The Rear Cabinet is equipped with two Cold-Cathode Tubes, each of which is located on the lamp unit to the left or right of the coin chute door.

To replace a Cold-Cathode Tube, remove the lamp unit from the Rear Cabinet.

- ① Turn off power.
- ② Remove the 2 truss screw and then Lamp Sash Upper.

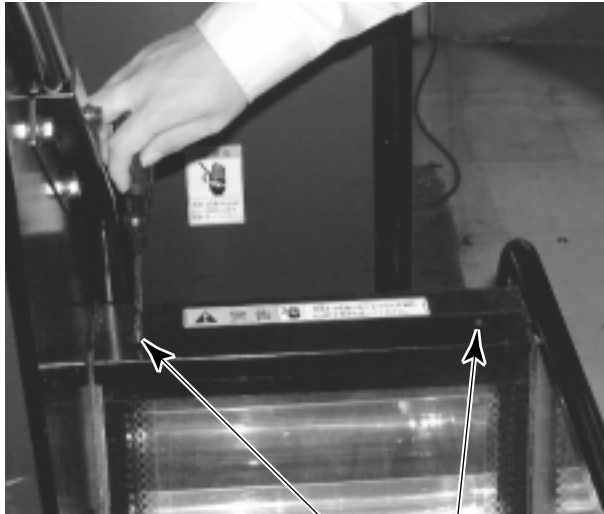

TRUSS SCREW (2), black
M4 X 8

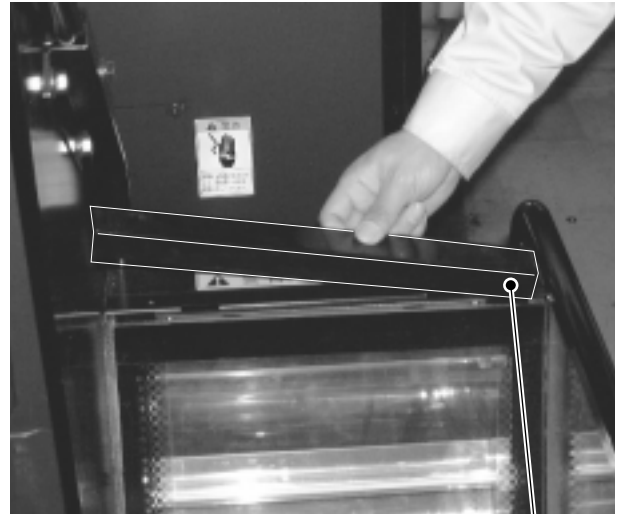

LAMP SASH UPPER

PHOTO 13 j

- ③ Remove the 2 truss screw and then Lamp Sash Lower.

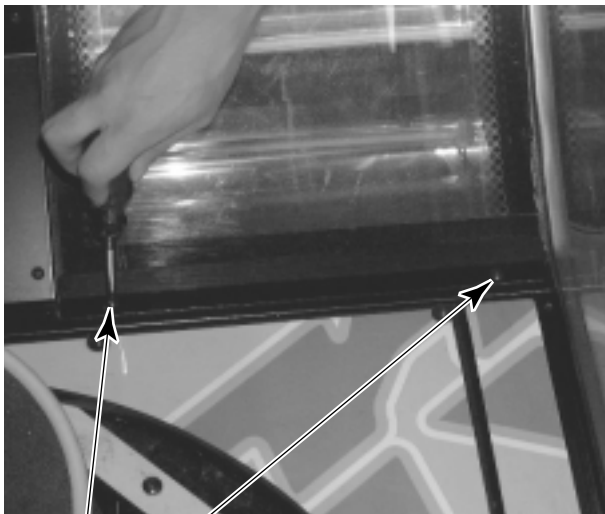

TRUSS SCREW (2), black
M4 X 8

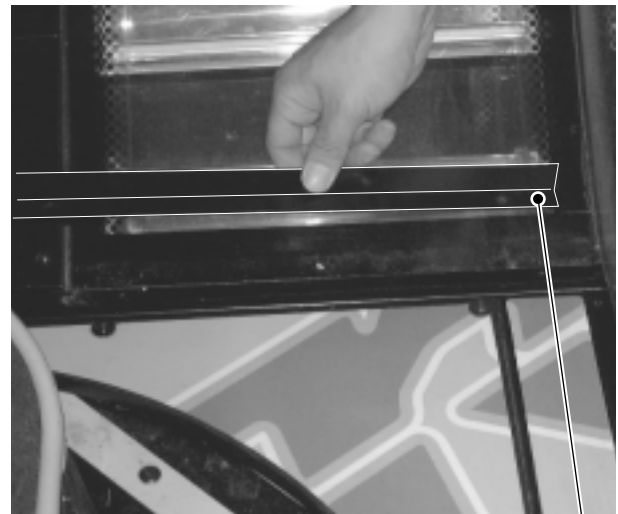

LAMP SASH LOWER

PHOTO 13 k

- ④ Remove the lamp panel by pulling it out downward. The panel is plastic. Pay attention to that applying load carelessly to it may cause it to break.

LAMP PANEL



PHOTO 13 l

- ⑤ Remove the 4 screws securing the lamp unit.

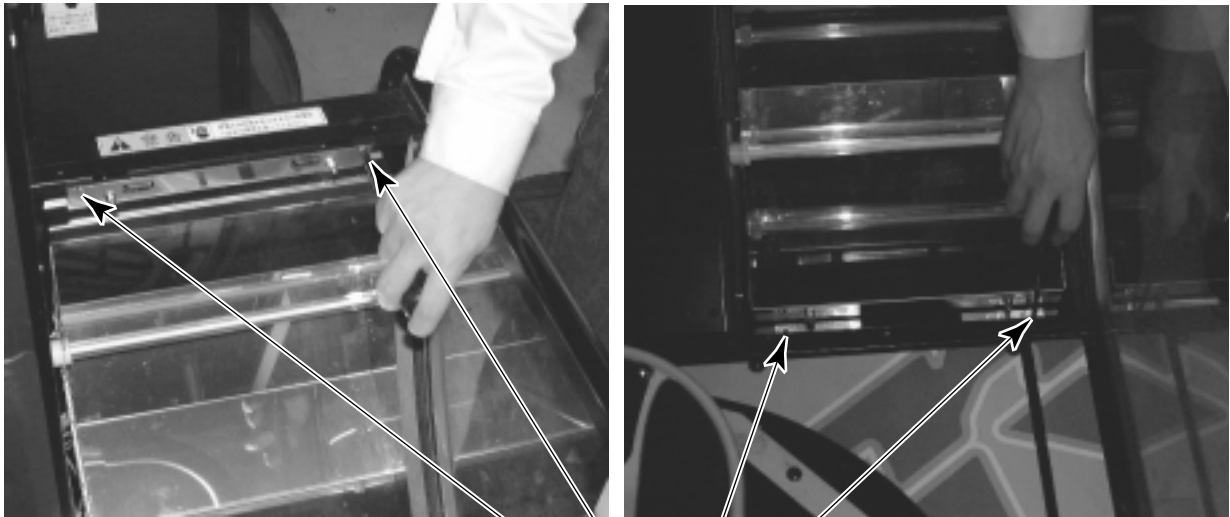

SCREW (4), black
M4 X 10, w/flat & spring washers

PHOTO 13 m

- ⑥ With the lamp unit tilted, pull out the inside connector.
- ⑦ Remove the lamp unit from the Rear Cabinet.

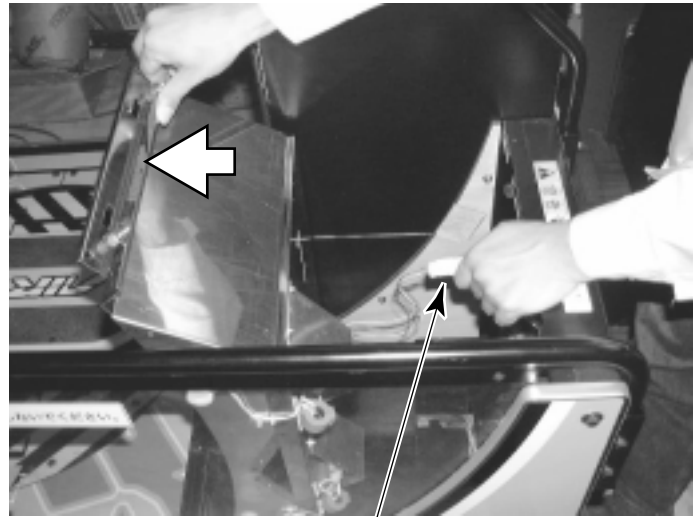

Disconnect the connector.

PHOTO 13 n

- ⑧ Unfasten the wire that is from the Cold-Cathode Tube. Then, pull out the connector connected to the Inverter BD.

Disconnect the connector.

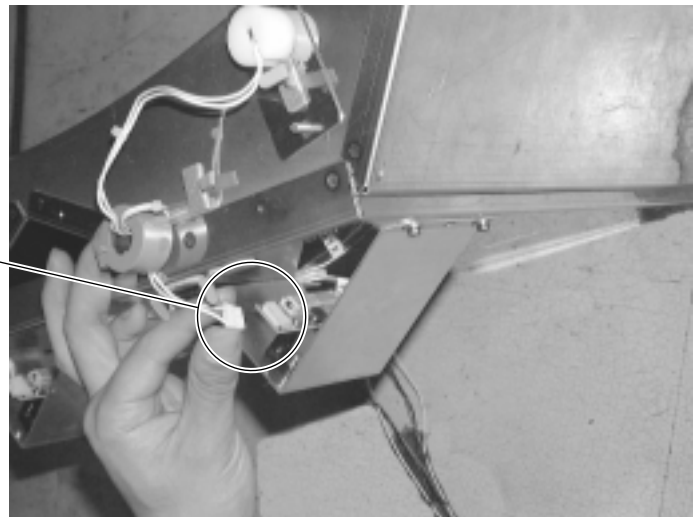

PHOTO 13 o

- ⑨ Remove the flange nut securing each of the flange nuts to the left and right of the Cold-Cathode Tube.

FLANGE NUT (one each)
M4

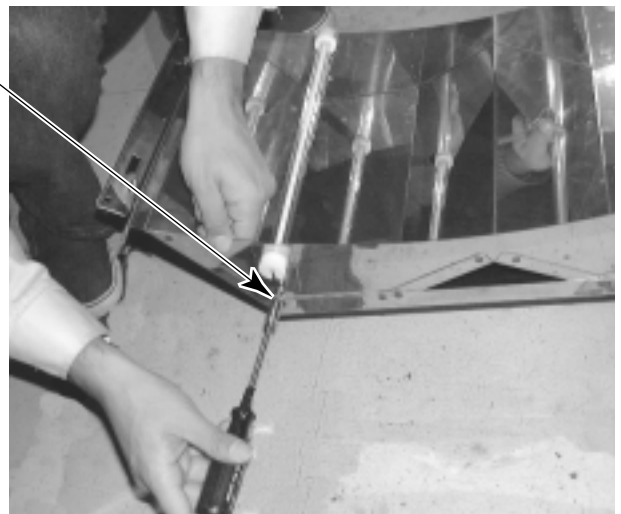

PHOTO 13 p

- ⑩ Remove the Cold-Cathode Tube from the lamp unit, and replace it with a new one.

COLD-CATHODE TUBE
390-6697-BL



PHOTO 13 q

Cold-Cathode Tube Inverter BD

Any trouble of turning on/off a Cold-Cathode Tube may be due to breakage of the Inverter BD for the Cold-Cathode Tubes as well as the end of the safe useful life or failure of the lamp unit itself. On its backside, the lamp unit is equipped with the Inverter BD for the respective Cold-Cathode Tubes.

- ① Remove the lamp unit by using the same procedure that was used to replace the Cold-Cathode Tube.
- ② Unfasten the wire connected to the Inverter BD. Then, pull out the connectors each located at either side of the BD.

Disconnect the connector.

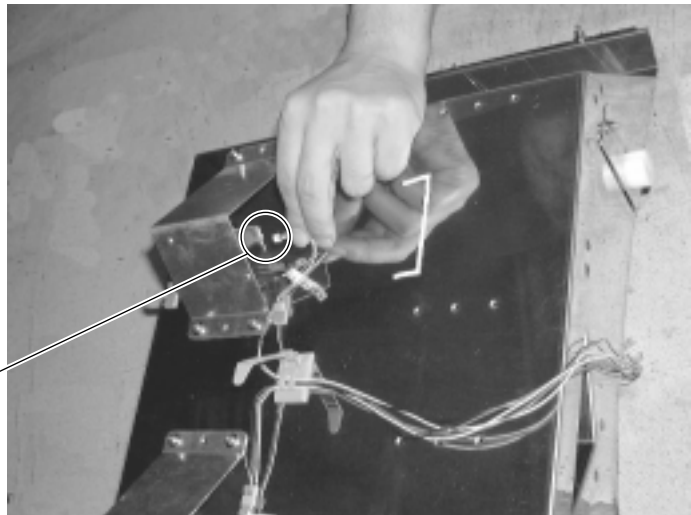
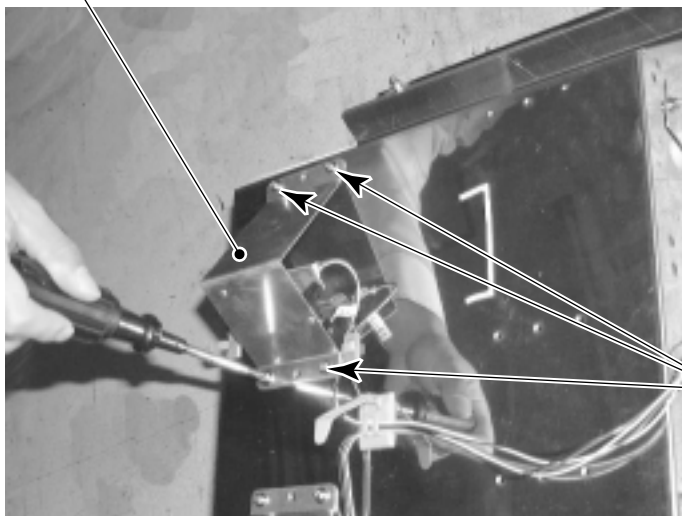

PHOTO 13 r

INVERTER BRACKET



- ③ Remove from the lamp unit the inverter bracket on which the Inverter BD is placed. Remove the 4 securing screws.

SCREW (4)
M4 X 8, w/flat & spring washers

PHOTO 13 s

- ④ Remove the Inverter BD from the inverter bracket, and replace it with a new one. Remove the 2 securing screws.

INVERTER BD
838-14010-01

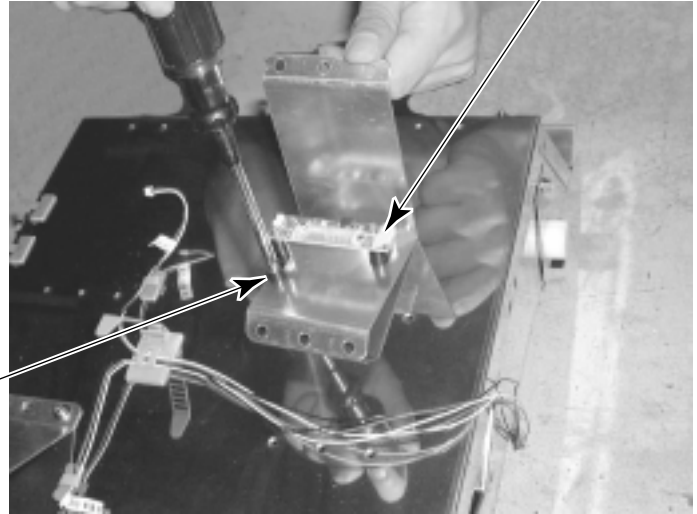

SCREW (2)
M3 X 10, w/flat & spring washers

PHOTO 13 t

14. PERIODIC INSPECTION TABLE

The items listed below require periodic check and maintenance to retain the performance of this machine and to ensure safe business operation.



WARNING!

- Be sure to check once a year to see if Power Cords are damaged, the plug is securely inserted, dust is accumulated between the Socket Outlet and the Power Plug, etc. Using the product with dust as is accumulated can cause fire and electric shock hazards.
- Periodically once a year, request the place of contact herein stated or the Distributor, etc. where the product was purchased from, as regards the internal cleaning. Using the product with dust as is accumulated in the interior without cleaning can cause a fire or accident. Note that cleaning the interior parts can be performed on a pay-basis.

TABLE 14

ITEMS	DESCRIPTION	PERIOD	REFERENCE
CABINET	Ensure that Adjusters are in contact with the floor.	Before commencing daily operation.	3
	Check hazard preventive parts.		
SKATE BOARD (Controller Board)	Check the Volume and Sensor.	Monthly	9
	Greasing the swing bearing	Monthly	10 - 3
	Greasing the Volume Control gears, crank sliding portion, and pinion gears	Trimonthly	10 - 3
PROJECTOR	SCREEN cleaning.	Weekly	11
	Check adjustments.	Monthly	6, 9, 11
COIN CHUTE DOOR	Coin insertion test	Monthly	12
	Cleaning	Trimonthly	12
GAME BD	MEMORY TEST	Monthly	9
	Setting check		
ITERIOR	Cleaning	Annually	See above.
POWER PLUG	Inspection and cleaning		
CABINET SURFACE	Cleaning	As necessary	See below.

CLEANING THE CABINET SURFACES

When the cabinet surfaces are badly soiled, remove stains with a soft cloth dipped in water or diluted (with water) chemical detergent and squeezed dry. To avoid damaging surface finish, do not use such solvents as thinner, benzine, etc. other than ethyl alcohol, or abrasives, bleaching agent and chemical dustcloth.

15. TROUBLESHOOTING



- In order to prevent electric shock and short circuit, be sure to turn power off before performing work.
- Be careful so as not to damage wirings. Damaged wiring can cause electric shock or short circuit.
- After removing the cause of the functioning of the Circuit Protector, reinstate the Circuit Protector. Depending on the cause of the functioning, using the Circuit Protector as is without removing the cause can cause generation of heat and fire hazard.

In case a problem occurs, first check wiring connector connections.

15 - 1 TABLE OF TROUBLESHOOTING

TABLE 15 a

PROBLEMS	CAUSE	COUNTERMEASURES
When the main SW is turned ON, the machine is not activated.	The power is not ON.	Firmly insert the plug into the outlet.
	Incorrect power source/voltage.	Make sure that the power supply/voltage are correct.
	The CIRCUIT PROTECTOR functioned due to momentary overcurrent.	Remove the cause of overload to reset the circuit protector (see Sec. 6 / FIG. 15. 1).

CIRCUIT PROTECTOR

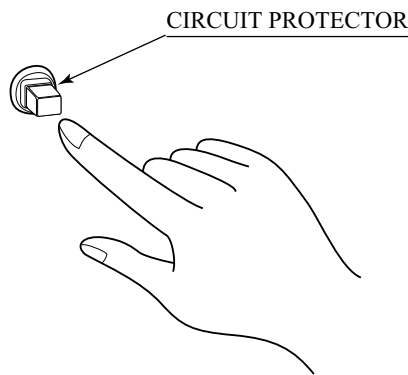

Functions due to the activation of bimetal. To restore the function, wait for approximately one minute or longer until the bimetal cools off. (Press the Button.)

FIG. 15. 1

TABLE 15 b

PROBLEMS	CAUSE	COUNTERMEASURES
Although sound is emitted, PTV screen is blackened and Fluorescent lamp does not light up.	Poor connection of connector between Front Cabinet and PTV.	Check for connection of 3p white connector (see Sec. 6).
The color on the PTV screen is not correct.	Poor connection of connector between Front Cabinet and PTV. Screen adjustment is not appropriate.	Check if R. G. B. and SYNC Connectors are correctly connected (see Sec. 6). Make adjustment appropriately (see Sec. 11).
PTV screen has a color deviation.	Affected by the periphery, such as other machines, location building's steel frames, etc.	Make convergence adjustments (see Sec. 11). Change installation direction/ position. Move the other machines which cause the problem.
Foot Controller operation is unsatisfactory.	Poor V. R. setting. V. R. deviation or malfunctioning. Poor mesh of GEAR.	Perform V. R. setting (see Sec. 9). Adjust or replace the V. R. (see Sec. 10). Adjust GEAR mesh (see Sec. 10).
Can not be unlocked.	Connection fault of connector between Front & Rear Cabinets.	Accurately connect the connector.
Irregular sound emitted from inside of Rear Cabinet.	Greasing to gear mesh portion is not satisfactory, or extraneous matter mixed in.	Apply greasing or eliminate extraneous matter (see Sec. 10).
Fluorescent Lamp does not light up.	Poor connection of connector in the Billboard. Fluorescent lamp need replacement.	Accurately connect the Connector (see Sec. 6). Replace Fluorescent Lamp (see Sec. 13).
The Cold-Cathode Tube does not blink normally.	Connection fault of connector between Front & Rear Cabinets. Cold-Cathode Tube need replacement. Failure of Inverter BD.	Accurately connect the connector (see Sec. 6). Replace the Cold-Cathode Tube (see Sec. 13). 390-6697-BL Replace the Inverter BD (see Sec. 13). 838-14010-01
Sound is not emitted.	Poor connection of connector between Front Cabinet and Rear Base. Sound volume is incorrect.	Accurately connect the connector (see Sec. 6). Adjust the Sound Volume Adjustment V. R. of the SW Unit (see Sec. 9).

15 - 2 SYSTEM ERROR MESSAGES

When you have connected the power or exited the GAME TEST MODE screen, the system may display an error message as listed below, if:

- A system-related failure is detected, or
- A setting does not conform to the specifications of the product.

If this is the case, you cannot play the game.

ERROR 1

Main board's serial ID is incorrect or unrecognizable. For repairing, ship it to a distributor from which you purchased the product.

ERROR 2

ROM board's serial ID is incorrect or unrecognizable. For repairing, ship it to a distributor from which you purchased the product.

ERROR 3

Serial ID cannot be set correctly on the main board. Reset the system by disconnecting and reconnecting the power. If the problem is still reproduced, ship it to a distributor, for repairing, from which you purchased the product.

ERROR 4

Monitor type is set incorrectly. Open the SYSTEM ASSIGNMENTS screen, select the MONITOR TYPE item, and reset it correctly.

ERROR 5

Display mode is set incorrectly. Open the SYSTEM ASSIGNMENTS screen, select the DISPLAY MODE item, and reset it correctly.

ERROR 6

Area code is not compatible between the main board and the game software saved in the ROM board. You cannot solve the problem by resetting.

ERROR 7

Cabinet type is set incorrectly. Open the SYSTEM ASSIGNMENTS screen, select the CABINET TYPE item, and reset it correctly.

ERROR 8

Jumper is set incorrectly on the ROM board. For repairing, ship it to a distributor from which you purchased the product.

Usually, no error message is displayed except a setting error on the SYSTEM MENU screen. System error may occur when you have replaced a system-related part (game board etc.) with the one used by other games.

16. GAME BOARD



WARNING!

- In order to prevent electric shock and short circuit hazards, be sure to turn power off before performing work.
- Be careful so as not to damage wirings. Damaged wiring can cause fire, electric shock and short circuit hazards.
- Do not expose the Game BD, etc. without a good reason. Failure to observe this can cause electric shock hazard or malfunctioning.



CAUTION!

The electronic parts on the IC Board could be damaged due to human body's static electricity. Before performing IC Board related work, be sure to discharge physically accumulated statics by touching grounded metallic surfaces, etc.



IMPORTANT

Put the Game Board in the Carton Box (an accessory) together with the Shield Case when requesting for the replacement or repair. Transporting the Game Board in an undesignated status for replacement/repair is unacceptable. In this manual, how to remove the Game Board is explained for convenience. However, this work should be performed by SEGA SERVICEMAN.

16 - 1 REMOVING THE GAME BOARD

The Game Board and all the other IC boards are located on the back of the Front Cabinet.

- ① Turn off power.
- ② Remove the 2 truss screws securing the Back Door.

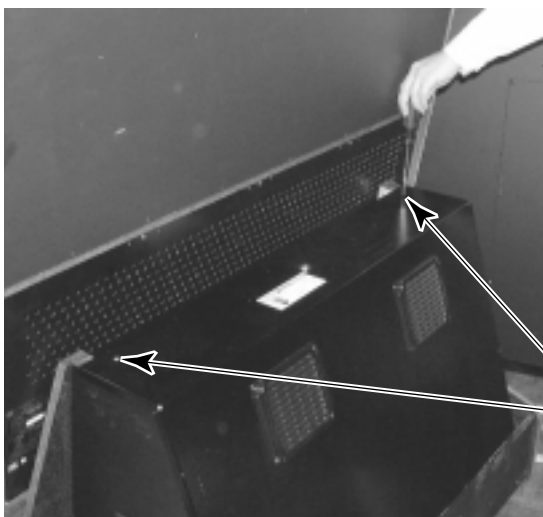

TRUSS SCREW (2), black
M4 X 20

PHOTO 16. 1 a

- ③ Unlock and remove the Back Door.
 The Game Board is located in the shield case inside the door.
 Take off 3 screws to remove Shield Case Lid, and the Game Board appears. This work should never be performed by those other than Sega Serviceman.



PHOTO 16.1 b

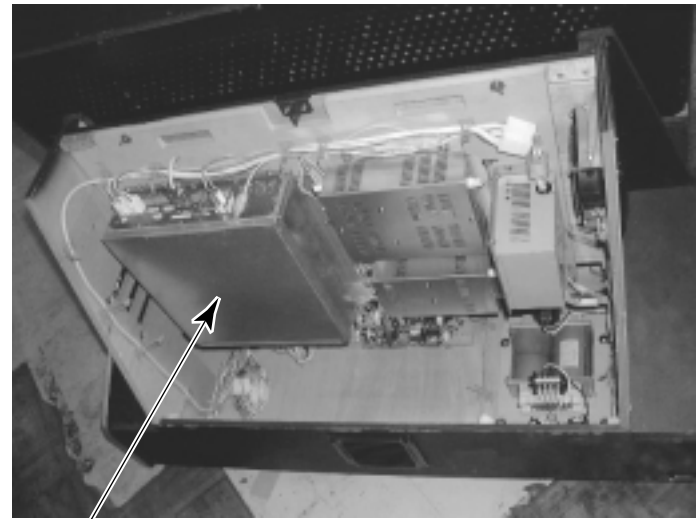

SHIELD CASE

PHOTO 16.1 c

- ④ Disconnect all connectors connecting to the Filter Board of Shield Case.
- ⑤ Take off 4 screws which secure the Shield Case to the Base (wooden base) and take out Shield Case from the Cabinet.
- ⑥ Take off 2 screws for each and remove 2 Shield Case Brackets from the Shield Case. Pack up the Shield Case with packing materials, put it into a carton box, and request service.

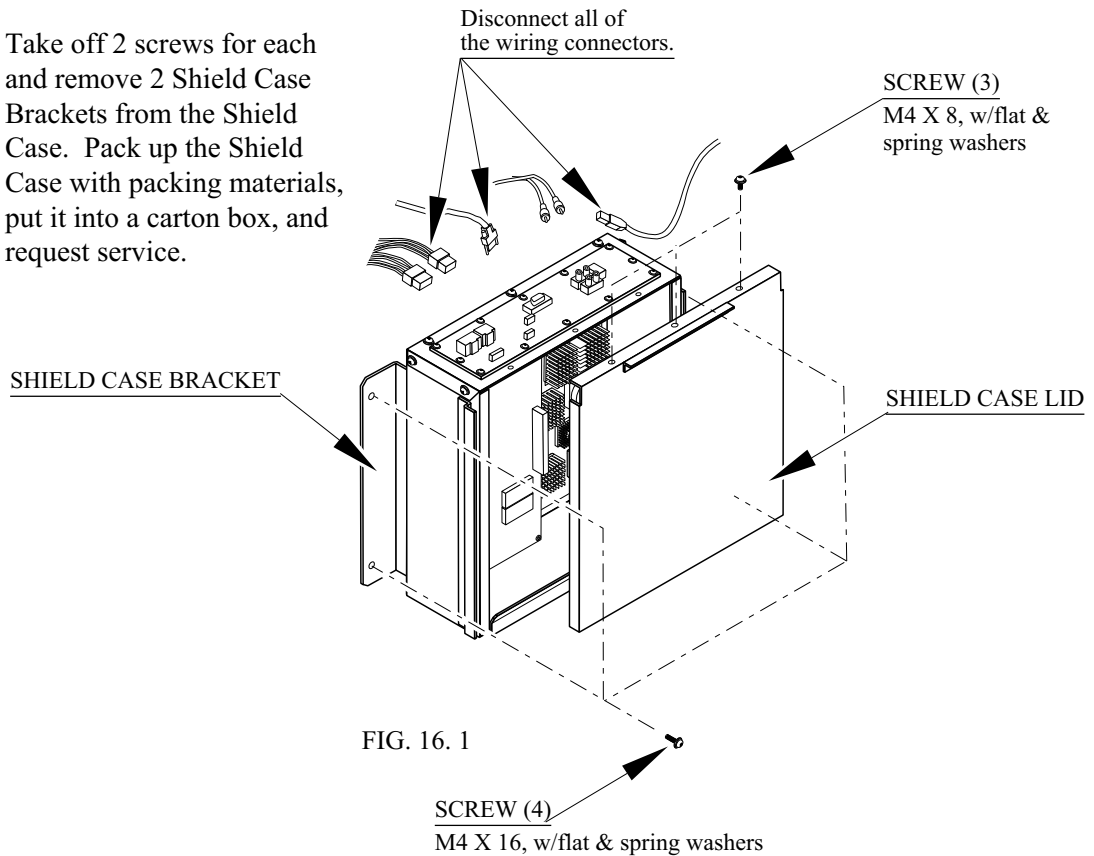

FIG. 16.1

SCREW (4)
 M4 X 16, w/flat & spring washers

16 - 2 COMPOSITION OF GAME BOARD

GAME BD ATR (833-14150)

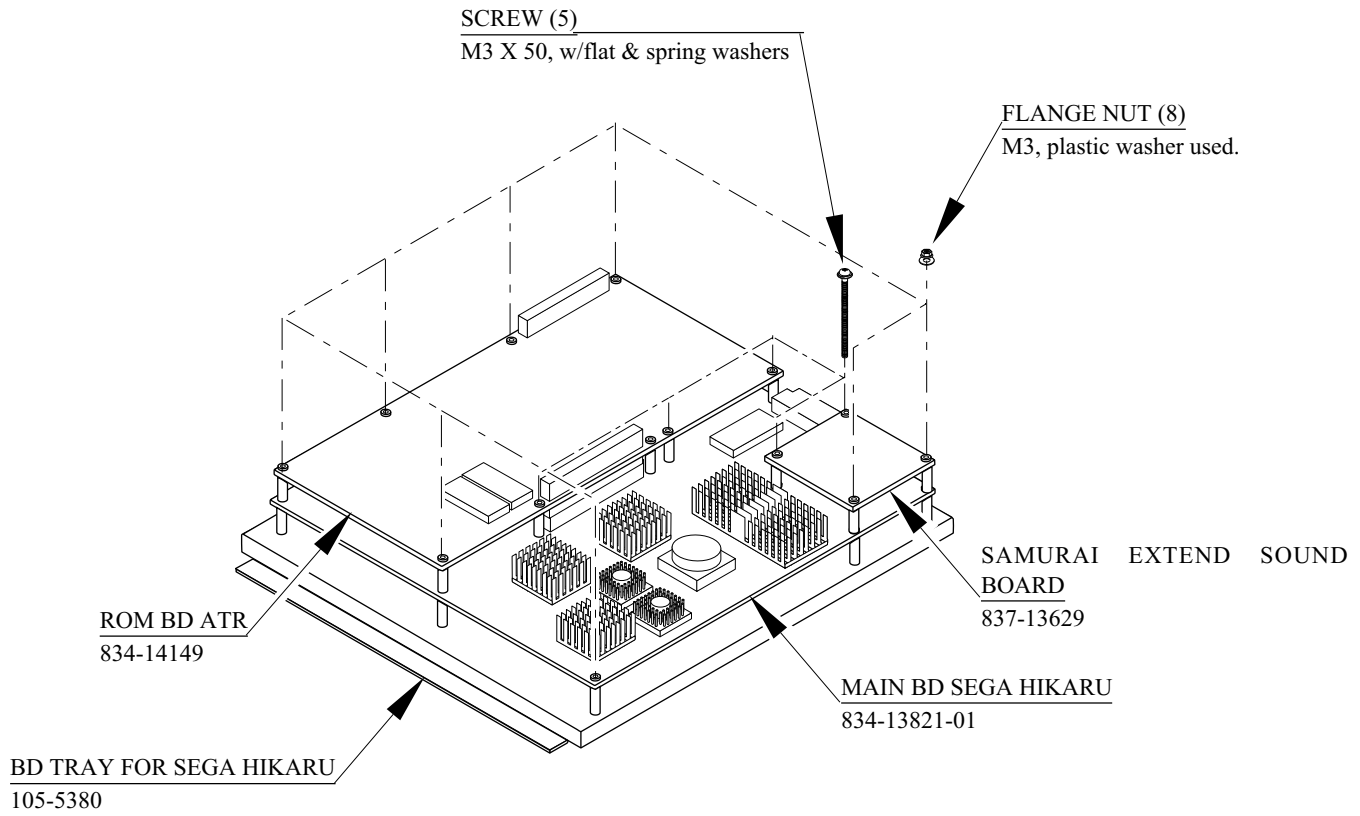

FIG. 16.2

ROM BD JUMPER SETTING	
JP3	2-3
JP4	2-3
JP5	2-3
JP6	2-3

MAIN BD JUMPER SETTING	
JP4	1-2
JP5	1-2
JP6	1-2
JP7	1-2
JP8	2-3
JP9	2-3
JP10	1-2
JP11	2-3

17. DESIGN RELATED PARTS

For the Warning Display stickers, refer to Section 1.

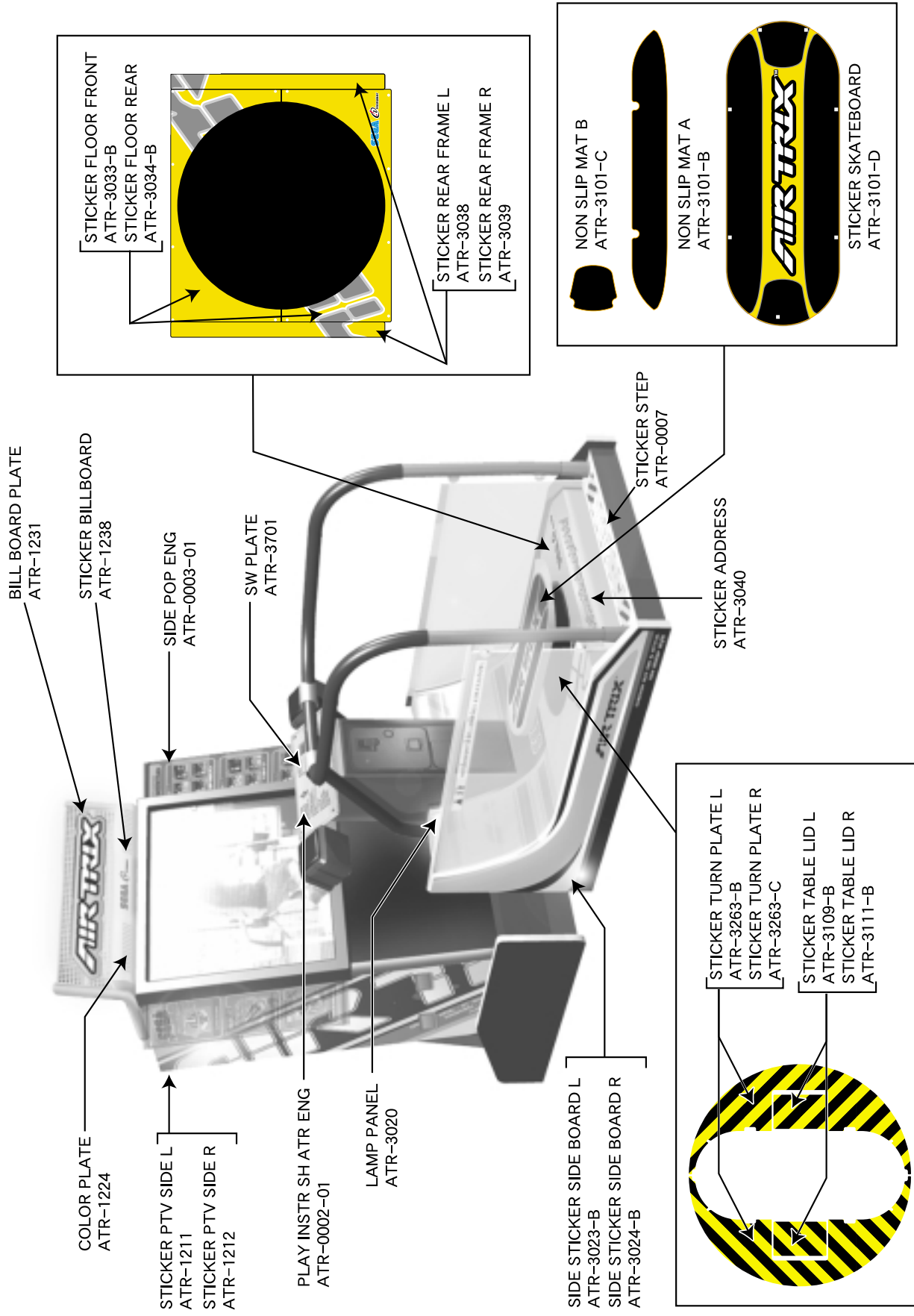

18. PARTS LIST

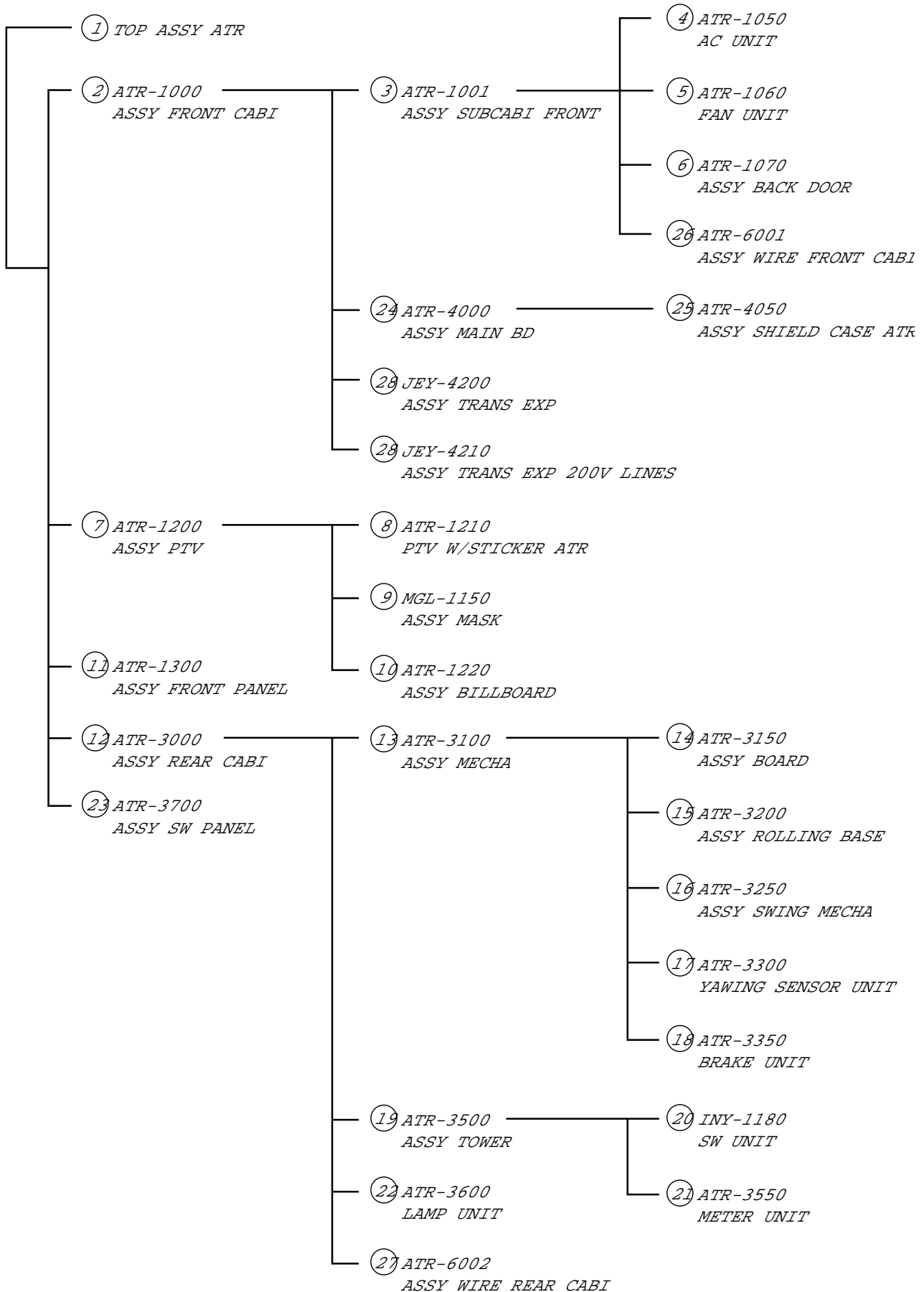

① TOP ASSY ATR

(D-1/2)

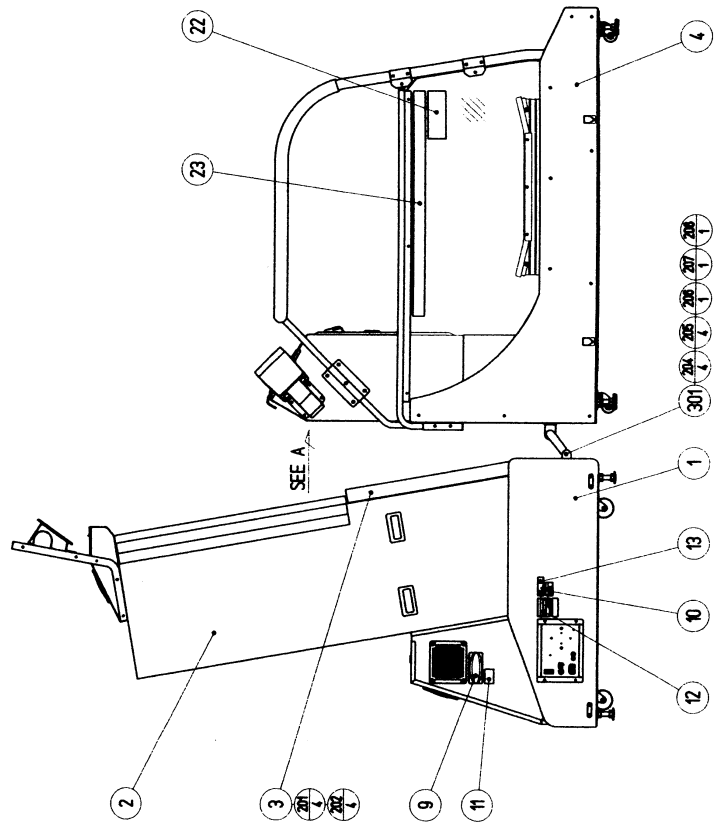
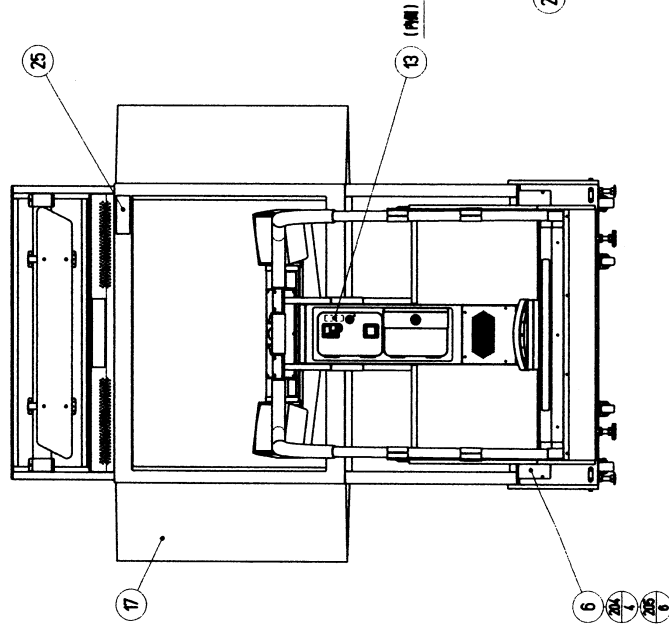
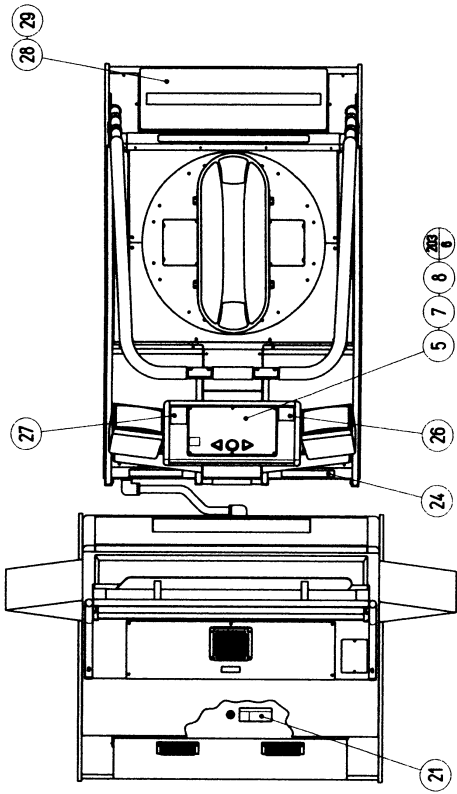

① TOP ASSY ATR

(D-2/2)

ITEM NO.	PART NO.	DESCRIPTION	NOTE
1	ATR-1000	ASSY FRONT CABI	
2	ATR-1200	ASSY PTV	
3	ATR-1300	ASSY FRONT PANEL	
4	ATR-3000	ASSY REAR CABI	
5	ATR-3700	ASSY SW PANEL	
6	ATR-0001	HOLE LID	
7	ATR-0002-01	PLAY INSTR SH ATR ENG	
8	421-7308- ~	DENOMI SH 1GAME ~	
14	421-8479-01	STICKER INSTR SUNLIGHT ENG	
15	SGM-4306	POLYE COVER 1100 X 1200 X 1000	
16	SGM-4469	POLY COVER 1000 X 1700 X 1100	
17	ATR-0003-01	SIDE POP ENG	
20	440-WS0002XEG	STICKER W POWER OFF ENG	
21	440-WS0033XEG	STICKER W BD POWER OFF ENG	
22	440-CS0231-EG	STICKER C PANEL ATR ENG	
23	440-CS0122-EG	STICKER C FENCE ENG	
24	440-WS0143-EG	STICKER W POWER OFF WIDE ENG	
25	440-CS0175-EG	STICKER C EPILEPSY ENG	
26	440-CS0232-EG	STICKER C ATR A ENG	
27	440-CS0233-EG	STICKER C ATR B ENG	
28	440-CS0234-EG	STICKER C STEP ATR ENG	
29	ATR-0007	STICKER STEP	
201	000-T00520-0B	M SCR TH BLK M5 X 20	
202	068-552016-0B	FLT WSHR BLK 5.5-20 X 1.6	
203	000-T00410-0C	M SCR TH CRM M4 X 10	
204	000-P00410-WB	M SCR PH BLK W/FS M4 X 10	
205	000-T00420-0B	M SCR TH BLK M4 X 20	
206	050-H00400	HEX NUT M4	
207	060-S00400	SPR WSHR M4	
208	060-F00400	FLT WSHR M4	
301	ATR-60030	WH DC TUBE	
401	601-6604-70	CARTON BOX 70	
402	SGM-2675	POLYETHYLENE BAG 240 X 370	
403	420-6614-01	OWNERS MNL ATR ENG	
404	600-6664-02	WIRE HARN EARTH W/LUG M6 NOT USED	TAIWAN OTHERS
405	390-5160	LAMP WG B TYPE 6V 3W (C2R)	
406	600-6729	AC CABLE CONNECT TYPE 15A	TAIWAN
	600-6619	AC CABLE CONNECT TYPE FOR UK	HONG KONG
	600-6618	AC CABLE CONNECT TYPE FOR EXP	AC 220 ~ 240V AREA
	600-6695	AC CABLE CONNECT TYPE USA 15A	USA
407	SGM-4111	KEY BAG	
408	220-5576	KEY MASTER FOR 220-5575	
409	280-5009-01	CORD CLAMP 21	
411	220-5484	VOL CONT B-5K OHM	
412	540-0064	GREASE GUN KH-120	
413	090-0275	GREASE ALBANIA EP-1 400G	
/	105-5356	SHIPPING BRKT	
/	421-8740	CAUTION INSTR COP U/R	
/	421-6690-03	STICKER 220V	AC 220V AREA
/	421-6690-06	STICKER 110V	AC 110V AREA
/	421-6690-01	STICKER 120V	AC 120V AREA
/	421-6119-91	STICKER FCC	
/	421-6120-92	STICKER SEGA USA	USA

② ASSY FRONT CABI (ATR-1000)

(D-1/2)

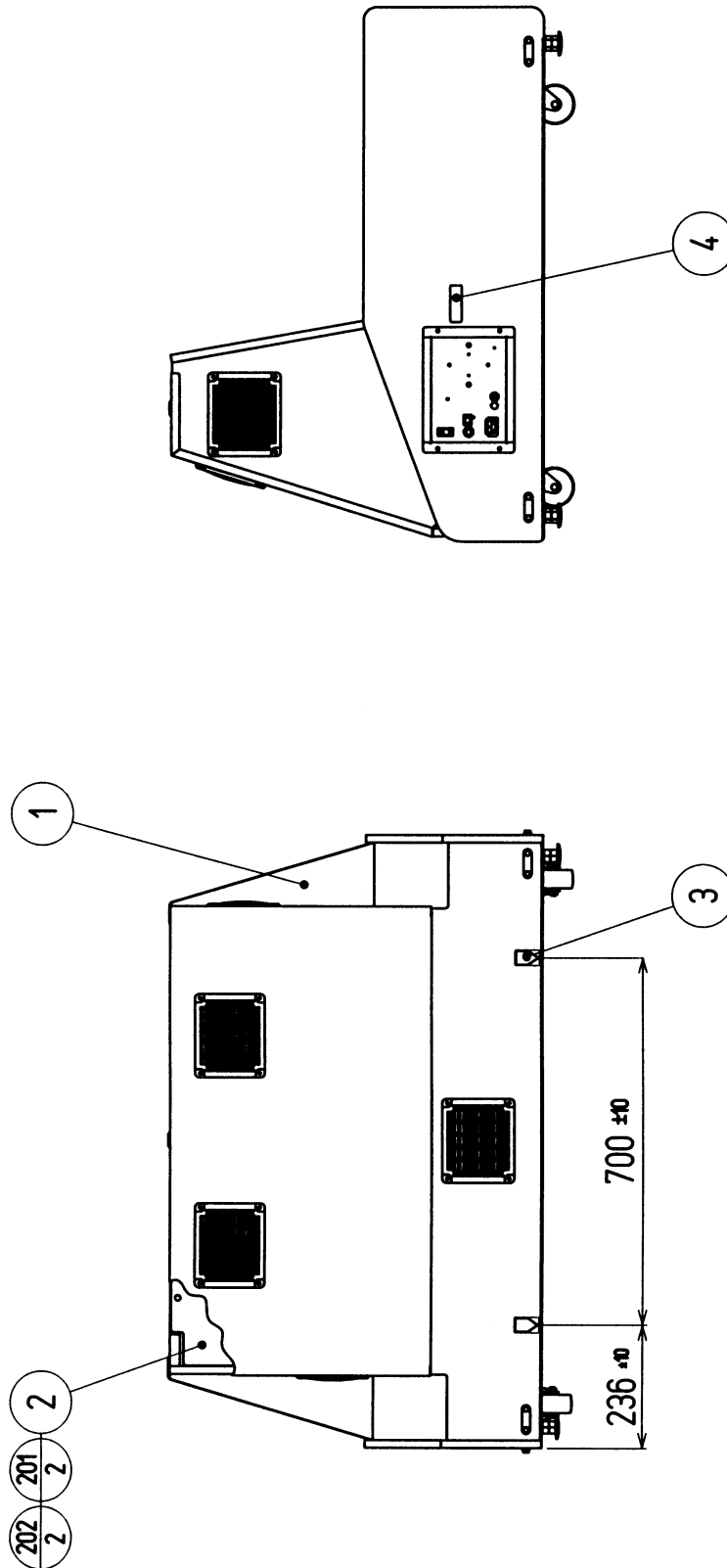

② ASSY FRONT CABI (ATR-1000)

(D-2/2)

ITEM NO.	PART NO.	DESCRIPTION	NOTE
1	ATR-1001	ASSY SUBCABI FRONT	
2	ATR-4000	ASSY MAIN BD	
3	421-8885	STICKER CAUTION FORK	
201	000-P00530-S	M SCR PH W/S M5 X 30	
202	068-552016	FLT WSHR 5.5-20 X 1.6	
/	000-P00630	M SCR PH M6 X 30	
/	068-652016	FLT WSHR 6.5-20 X 1.6	
/	060-S00600	SPR WSHR M6	
/	JEY-4210	ASSY TRANS EXP 200V LINES	AC 220 ~ 240V AREA
/	JEY-4200	ASSY TRANS EXP	AC 110 ~ 120V AREA

③ ASSY SUBCABI FRONT (ATR-1001)

(D-1/2)

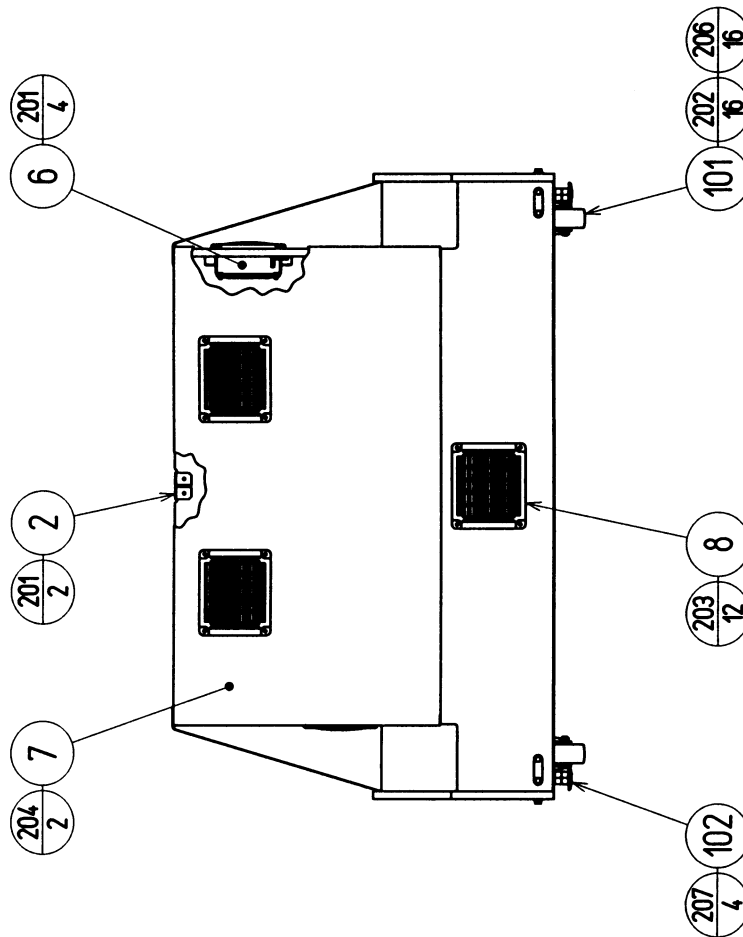
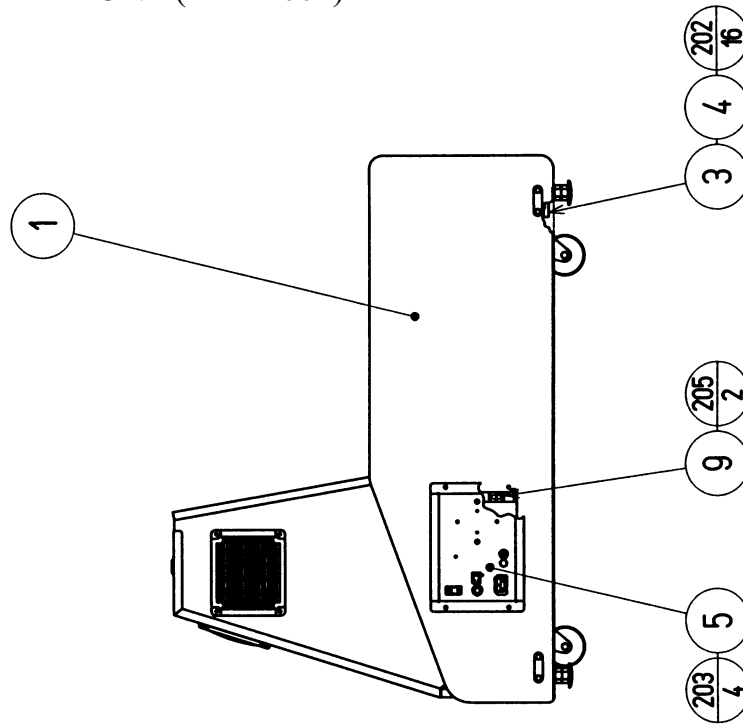

③ ASSY SUBCABI FRONT (ATR-1001)

(D-2/2)

ITEM NO.	PART NO.	DESCRIPTION
1	ATR-1002	FRONT CABI
2	ASK-1152	LOCK BRKT
3	ARC-1006	LEG BRACKET
4	117-5233	PLATE LEG BRACKET BLACK
5	ATR-1050	AC UNIT
6	ATR-1060	FAN UNIT
7	ATR-1070	ASSY BACK DOOR
8	253-5460-01	AIR VENT BLACK
9	117-5402-06-91	EARTH TERMINAL PLATE 6P
101	601-9377	CASTER FAI=75
102	601-5699X	LEG ADJUSTER BOLT M16 X 75
103	280-5009-01	CORD CLAMP 21
201	000-P00416-W	M SCR PH W/FS M4 X 16
202	030-000630-SB	HEX BLT BLK W/S M6 X 30
203	000-T00416-0B	M SCR TH BLK M4 X 16
204	000-T00420-0B	M SCR TH BLK M4 X 20
205	011-F00316	TAP SCR FH 3 X 16
206	060-F00600	FLT WSHR M6
207	050-H01600-0B	HEX NUT BLK M16
208	011-F00316	TAP SCR FH 3 X 16
301	ATR-6001	ASSY WIRE FRONT CABI
302	ATR-60021	WH AC OUT XFMR
303	ATR-60022X	WH EXT AC
304	600-7232-1200	WH EARTH VD1.25-4 1200MM
306	600-7009-2500	ASSY RGB CA D-SUB 15P 2500MM

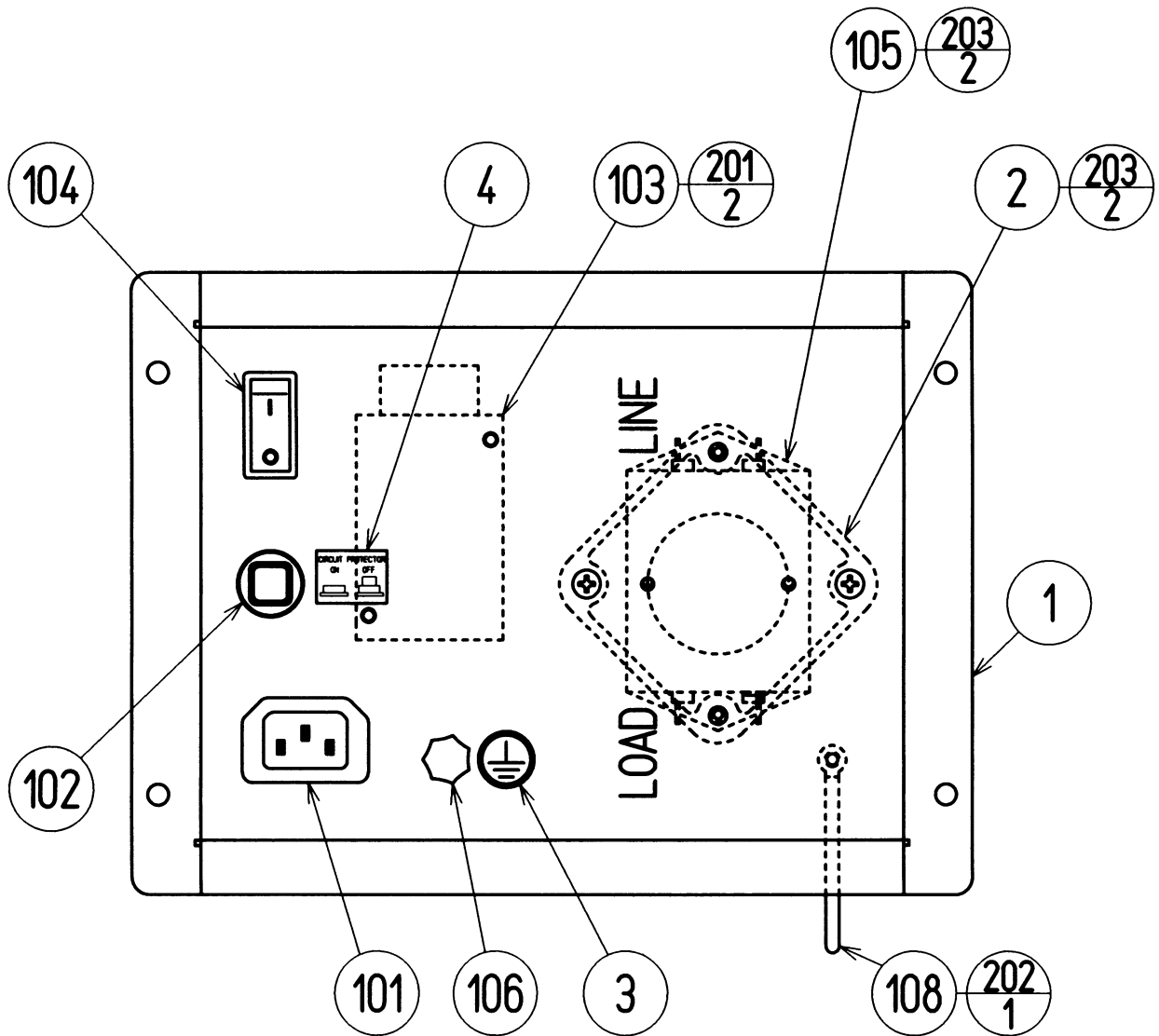

④ AC UNIT (ATR-1050)

(D-2/2)

ITEM NO.	PART NO.	DESCRIPTION	NOTE
1	JBA-1031	AC BRKT	
2	DYN-0402	NOISE FILTER BASE	
3	421-8202	STICKER EARTH MARK	
4	421-7468-01	STICKER C.P W/PIC	
101	214-0202	AC INLET PANEL TYPE	
102	512-5046-8000	C.P 8000MA CE UL	AC 110 ~ 120V AREA
	512-5046-5000	C.P 5000MA CE UL	AC 220 ~ 240V AREA
103	450-5126	MAGNET CONTACT S-NIOCX	TAIWAN
	450-5134	MAGNET CONTACT S-NIOCX AC 230V	OTHERS
	450-5133	MAGNET CONTACT S-NIOCX AC200V	KOREA
	450-5135	MAGNET CONTACT S-NIOCX AC120V	USA
104	509-5453-91-V-B	SW ROCKER J8 V-B	
105	270-5115	NOISE FILTER 15A GT-215J	
106	280-0417	TERMINAL BINDING POST BLACK	TAIWAN
		NOT USED	OTHERS
107	310-5029-K20	SUMITUBE F K 20MM	
108	280-0419	HARNESS LUG	
109	601-0460	PLASTIC TIE BELT 100MM	
201	000-P00416-WB	M SCR PH W/FS BLK M4 X 16	
202	000-P00408-WB	M SCR PH W/FS BLK M4 X 8	
203	012-P00408	TAP SCR #2 PH 4 X 8	
204	060-F00400	FLT WSHR M4	
205	060-S00400	SPR WSHR M4	
206	050-H00400	HEX NUT M4	
301	JBA-60001	WIRE HARN AC UNIT IN	
302	JBA-60002	WIRE HARN MAIN SW	
303	JBA-60003	WIRE HARN M.CONTACT & N.FILTER	
304	ATR-60100	WH AC UNIT OUT	
305	JBA-60037	WIRE HARN EARTH INLET	
306	600-7232-0350	WH EARTH VD1.25-4 350MM	

⑤ FAN UNIT (ATR-1060)

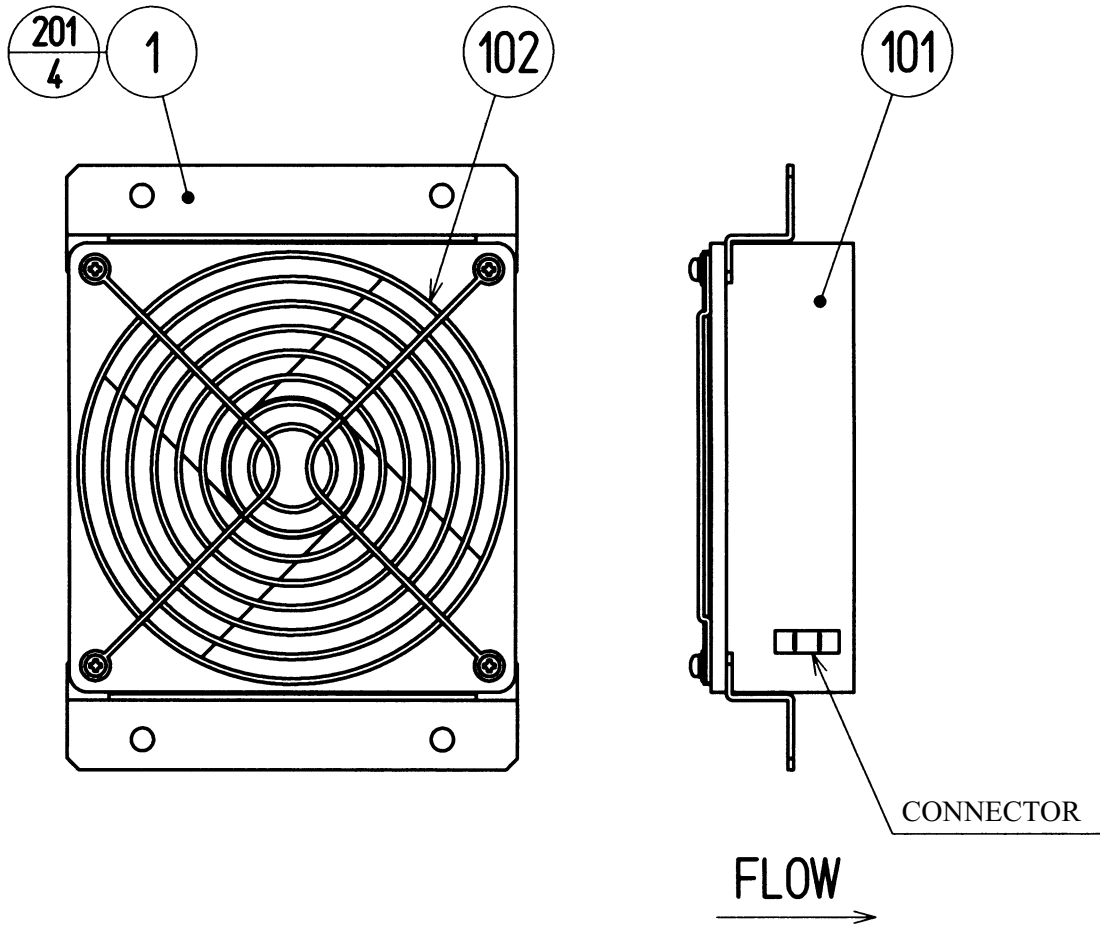

ITEM NO.	PART NO.	DESCRIPTION
1	ATR-1061	FAN BRKT
101	260-0011-02	AXIAL FLOW FAN AC100V 50-60HZ
102	601-8543	FAN GUARD
201	000-P00312-W	M SCR PH W/FS M3 X 12

⑥ ASSY BACK DOOR (ATR-1070)

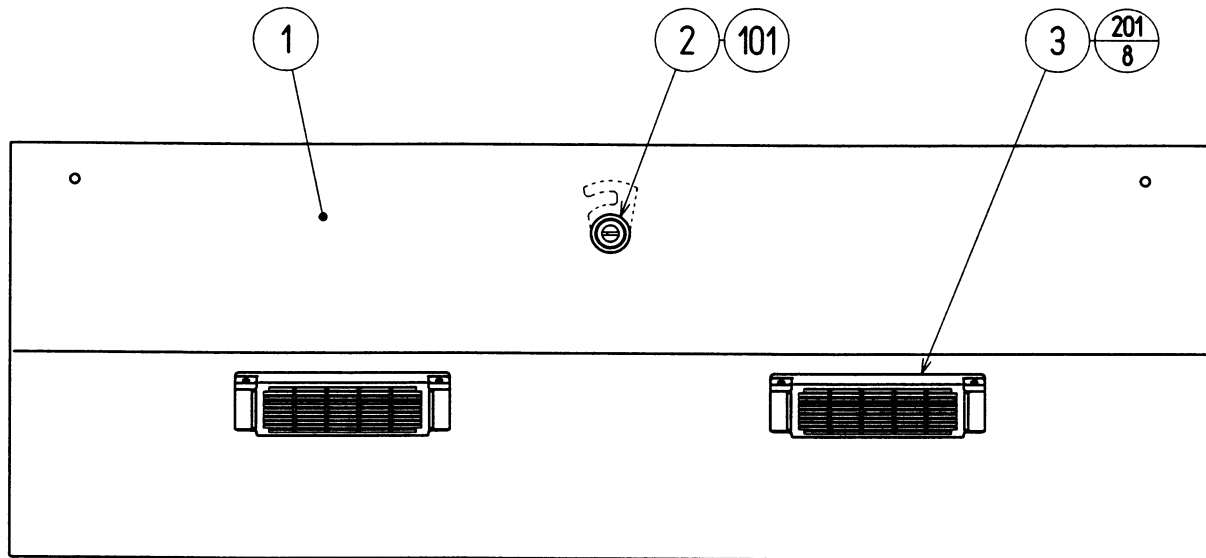

ITEM NO.	PART NO.	DESCRIPTION
1	ATR-1071	BACK DOOR
2	TH-1015	LOCKING TONGUE
3	253-5460-01	AIR VENT BLACK
101	220-5575	CAM LOCK MASTER W/O KEY
201	000-T00408-0B	M SCR TH BLK M4 X 8

⑦ ASSY PTV (ATR-1200)

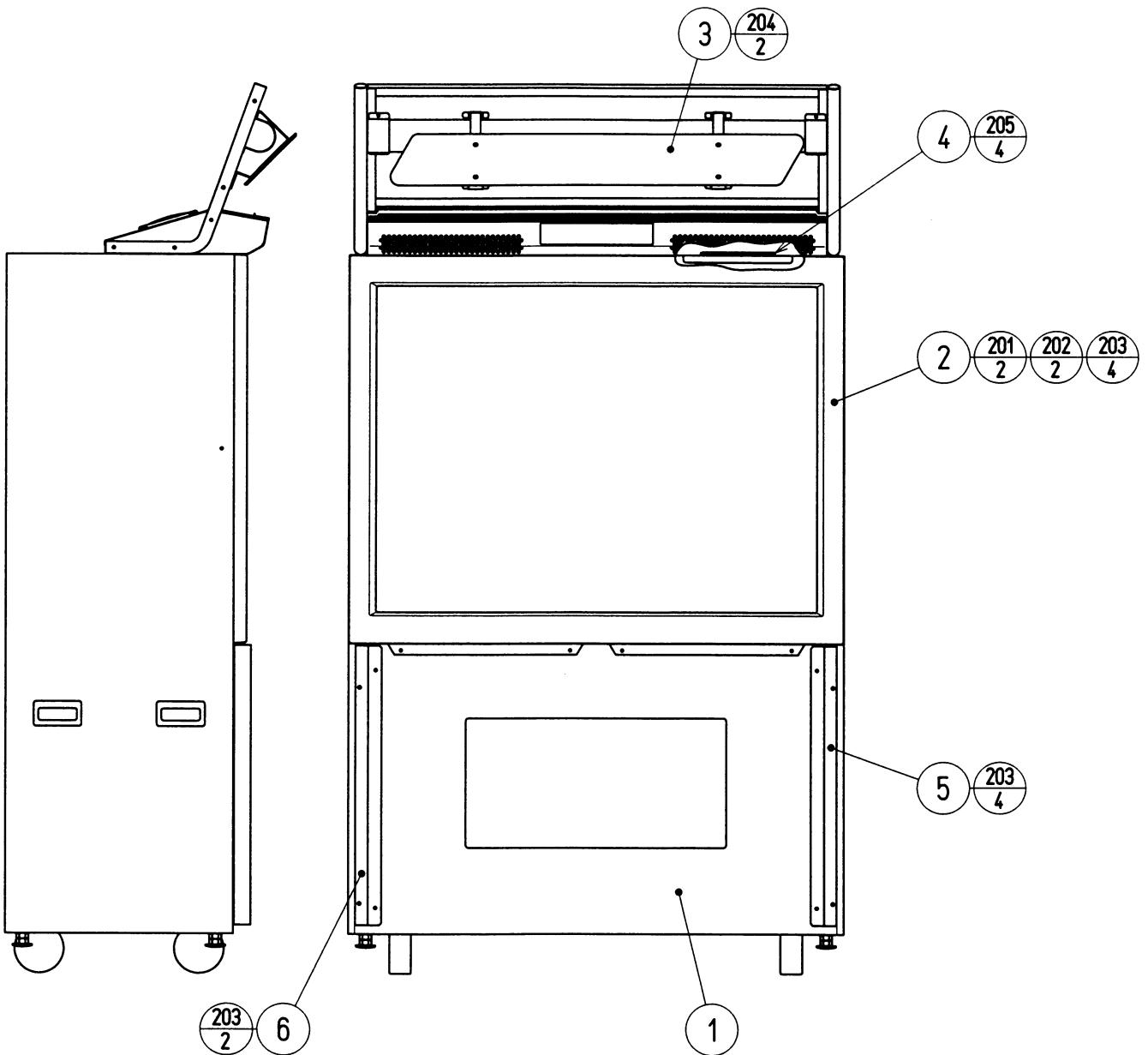

ITEM NO.	PART NO.	DESCRIPTION
1	ATR-1210	PTV W/STICKER ATR
2	MGL-1150	ASSY MASK
3	ATR-1220	ASSY BILLBOARD
4	RAL-0501	MASK HOLDER
5	DYN-0501	PANEL MOUNT BRKT L
6	DYN-0502	PANEL MOUNT BRKT R
201	000-T00525-0B	M SCR TH BLK M5 X 25
202	068-552016-0B	FLT WSHR BLK 5.5-20 X 1.6
203	000-P00520-WB	M SCR PH W/FS BLK M5 X 20
204	000-T00540-0C	M SCR TH CRM M5 X 40
205	000-F00412	M SCR FH M4 X 12

⑧ PTV W/STICKER ATR (ATR-1210)

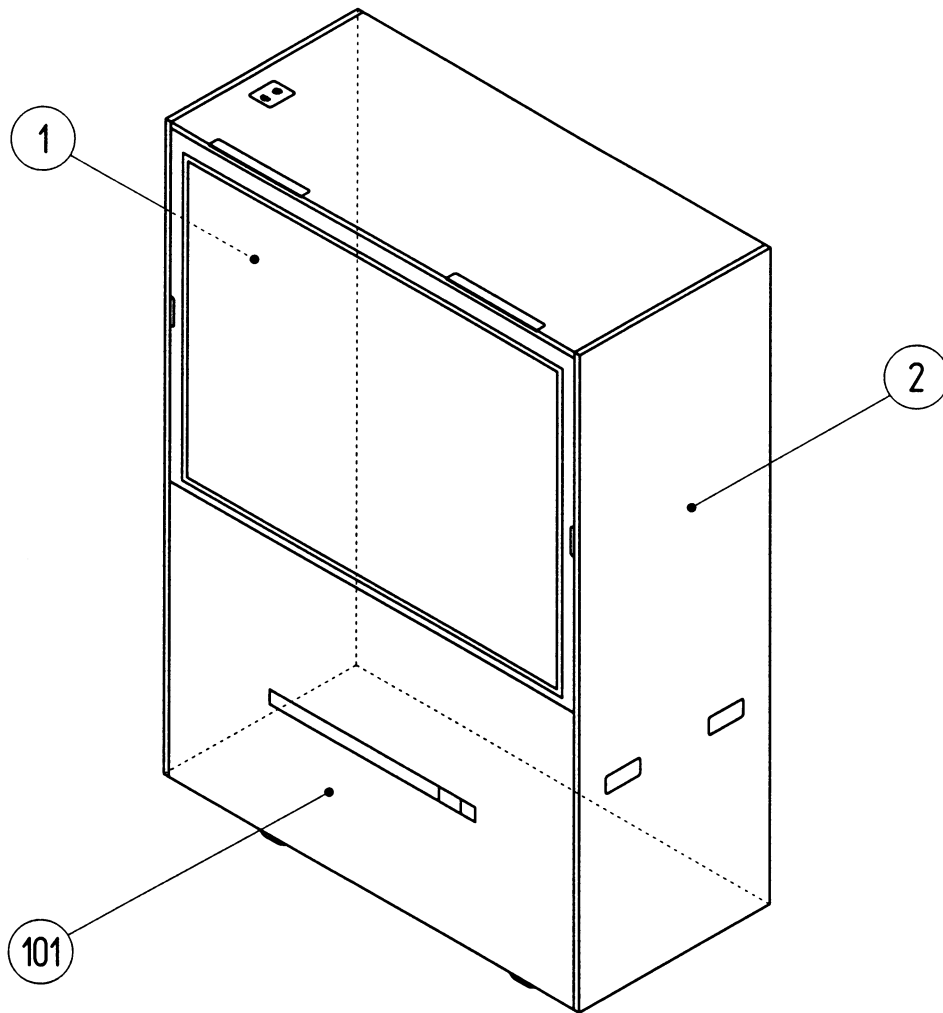

ITEM NO.	PART NO.	DESCRIPTION
1	ATR-1211	STICKER PTV SIDE L
2	ATR-1212	STICKER PTV SIDE R
101	200-5788-31 200-5799-31	PROJECTION DSPL T 50TYPE 31K PROJECTION DSPL M 50TYPE 31K

9 ASSY MASK (MGL-1150)

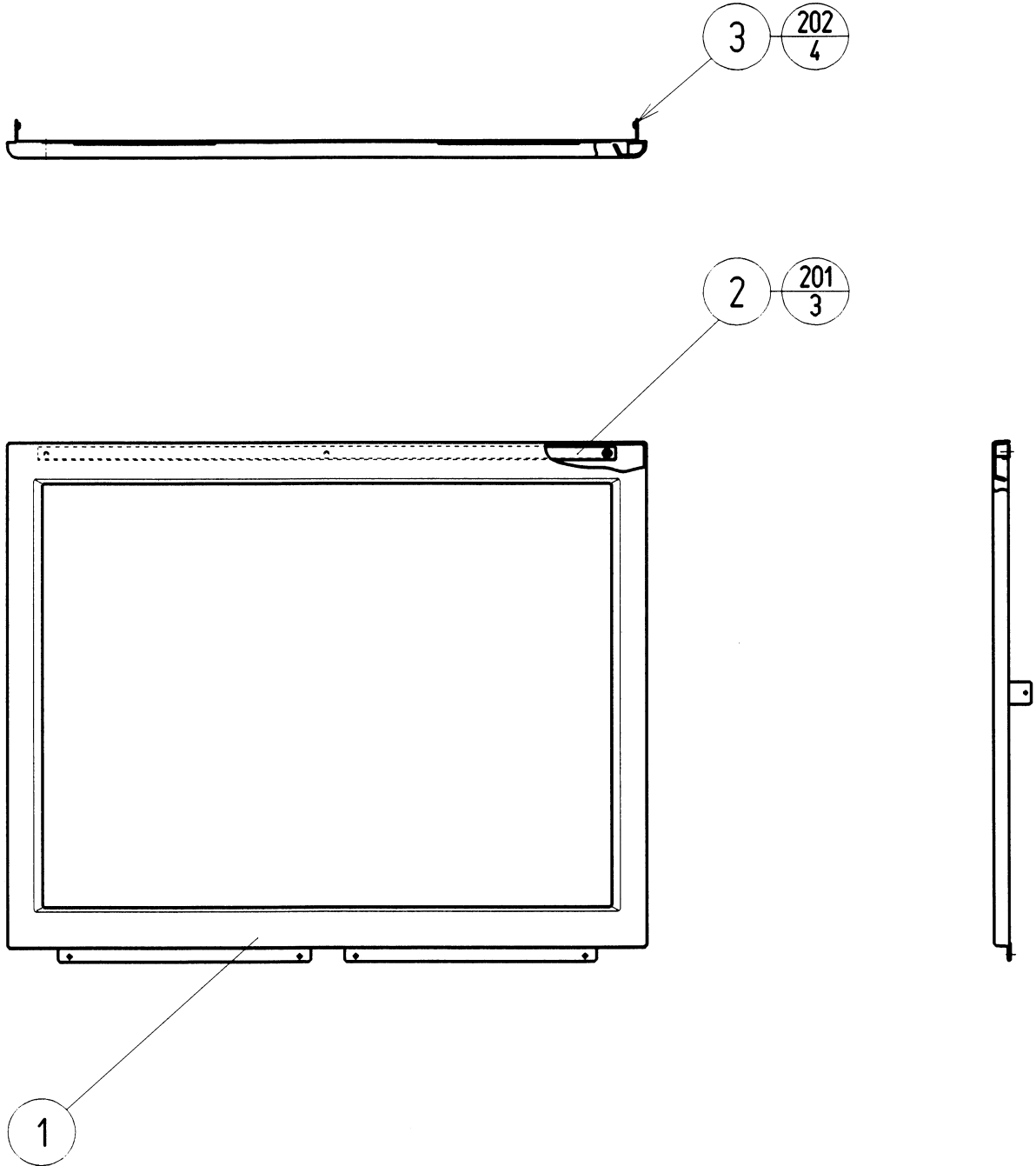

ITEM NO.	PART NO.	DESCRIPTION
1	MGL-1102	TV MASK
2	MGL-1151	SLIT PLATE
3	MGL-1152	MASK SIDE HOLDER
201	012-F00408-0B	TAP SCR FH BLK 4 X 8
202	000-F00410	M SCR FH M4 X 10

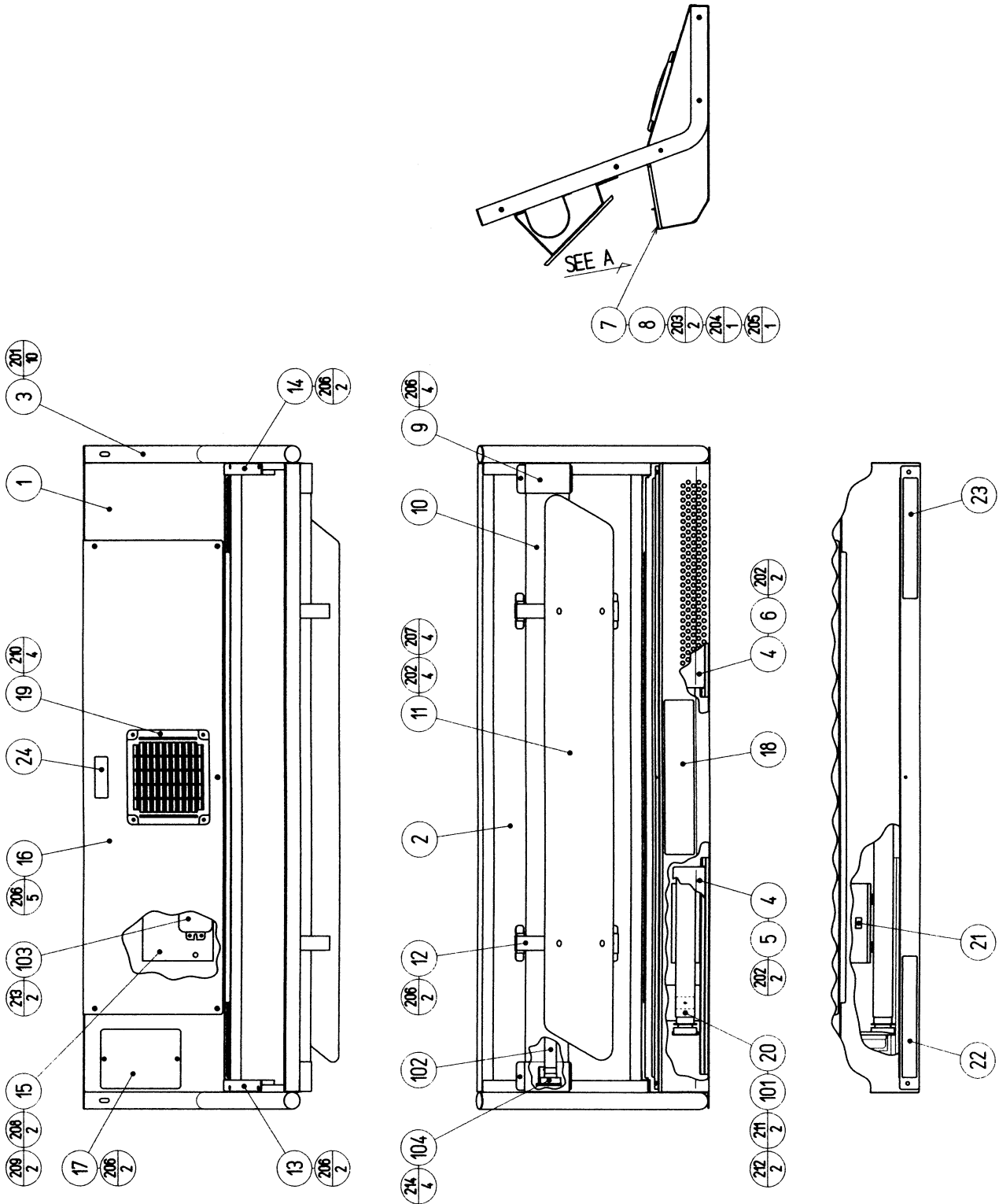

⑩ ASSY BILLBOARD (ATR-1220)

(D-2/2)

ITEM NO.	PART NO.	DESCRIPTION	NOTE
1	ATR-1221	BILLBOARD BASE	
2	ATR-1222	BACK PANEL	
3	ATR-1223	BILLBOARD PIPE	
4	ATR-1224	COLOR PLATE	
5	ATR-1225	HOLDER L	
6	ATR-1226	HOLDER R	
7	ATR-1227	PLATE SASH	
8	ATR-1228	FL COVER PLATE	
9	ATR-1229	ACRYL HOLDER	
10	ATR-1230	SLIM COVER	
11	ATR-1231	BILLBOARD PLATE	
12	ATR-1232	PLATE HOLDER	
13	ATR-1233	WIRE COVER L	
14	ATR-1234	WIRE COVER R	
15	ATR-1235	BALLAST BASE	
16	ATR-1236	BILLBOARD LID	
17	ATR-1237	HOLE LID	
18	ATR-1238	STICKER BILLBOARD	
19	253-5460-01	AIR VENT BLACK	
20	253-5457	FL HOLDER	OTHERS
		Locally supplied.	USA
21	421-7501-18	STICKER FL32W	OTHERS
		Locally supplied.	USA
22	440-WS0027-EG	STICKER W HIGH TEMP WIDE ENG	
23	440-WS0143-EG	STICKER W POWER OFF WIDE ENG	
101	LOC. PURCHASE	36" FL. LIGHT FIXTURE	
102	LOC. PURCHASE	36" FL. LAMP	
103	182-5078-AB	COIL BALLAST AB-116	OTHERS
		Locally supplied.	USA
104	214-0223-03	FL SOCKET W/CONN	OTHERS
		Locally supplied.	USA
105	280-5009-01	CORD CLAMP 21	
106	280-5275-SR10	CORD CLAMP SR10	
201	000-P00540-0C	M SCR PH CRM M5 X 40	
202	050-F00400	FLG NUT M4	
203	000-T00412-0C	M SCR TH CRM M4 X 12	
204	050-U00400	U NUT M4	
205	060-F00400	FLT WSHR M4	
206	000-T00408-0C	M SCR TH CRM M4 X 8	
207	031-000414-0C	CRG BLT CRM M4 X 14	
208	050-F00500	FLG NUT M5	
209	068-552016	FLT WSHR 5.5-20 X 1.6	
210	000-T00408-0B	M SCR TH BLK M4 X 8	
211	000-P00430-S	M SCR PH W/S M4 X 30	OTHERS
		Locally supplied.	USA
212	068-441616	FLT WSHR 4.4-16 X 1.6	OTHERS
		Locally supplied.	USA
213	000-P00412-W	M SCR PH W/FS M4 X 12	OTHERS
		Locally supplied.	USA
214	000-P00408-W	M SCR PH W/FS M4 X 8	OTHERS
		Locally supplied.	USA
215	011-F03516	TAP SCR FH 3.5 X 16	
301	ATR-60091	WH SLIM INV	
302	ATR-60092	WH SLIM	
303	ATR-60093	WH FL	

11 ASSY FRONT PANEL (ATR-1300)

(D-1/2)

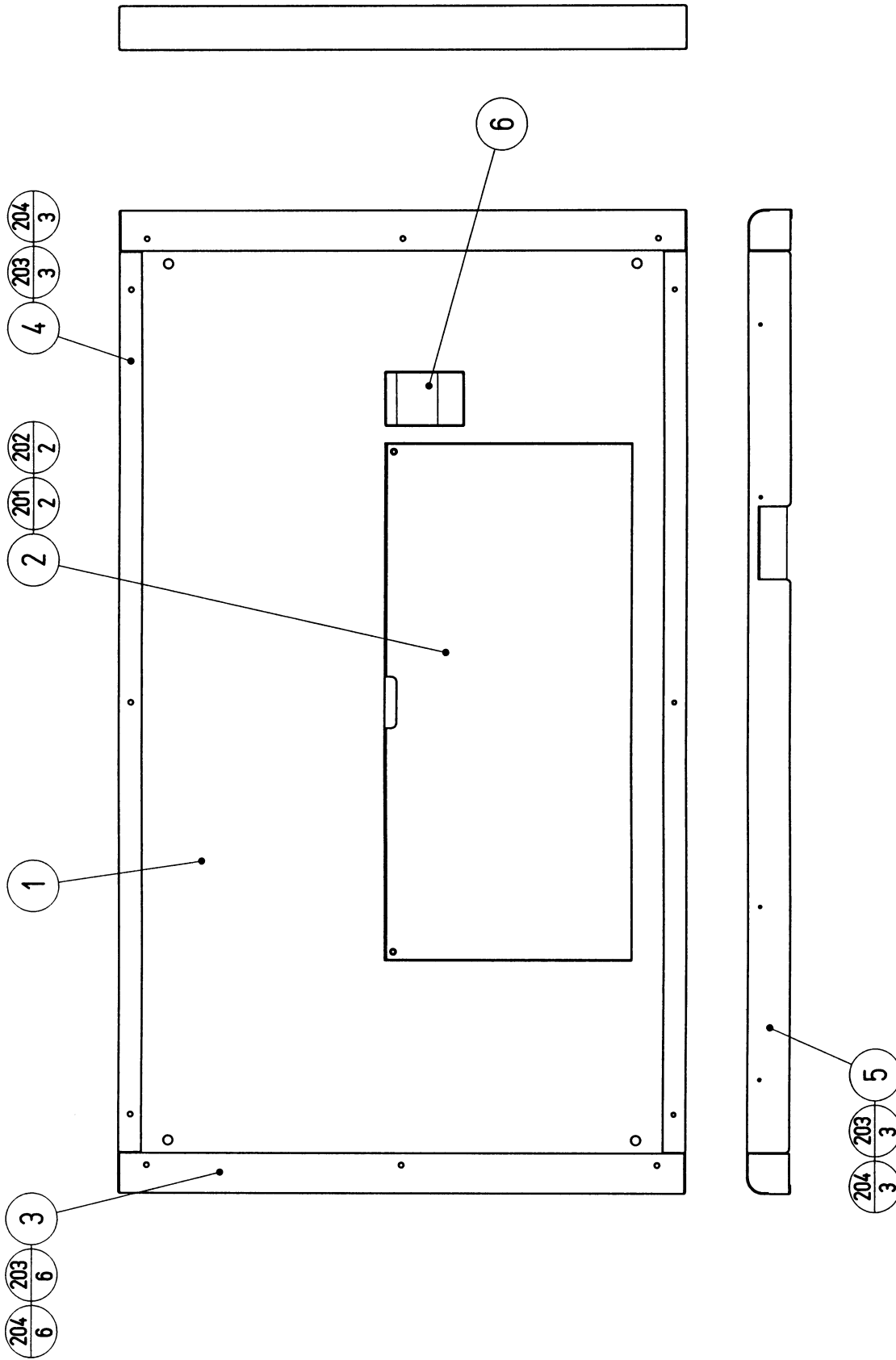

⑪ ASSY FRONT PANEL (ATR-1300)

(D-2/2)

ITEM NO.	PART NO.	DESCRIPTION
1	ATR-1301	FRONT PANEL
2	ATR-1302	FRONT LID
3	EZT-0603	SIDE BRKT
4	EZT-0604	BRKT UPPER
5	ATR-1303	BRKT LOWER
6	440-WS0002XEG	STICKER W POWER OFF ENG
201	000-T00420-0B	M SCR TH BLK M4 X 20
202	068-441616-0B	FLT WSHR BLK 4.4-16 X 1.6
203	050-F00500	FLG NUT M5
204	068-552016	FLT WSHR 5.5-20 X 1.6

12 ASSY REAR CABI (ATR-3000)

(D-1/3)

SCREW FASTENING TORQUE TO BE

M4	1.76N·m [18Kgf·cm]
M5	1.96N·m [20Kgf·cm]
M5	3.43N·m [35Kgf·cm]
M6	3.92N·m [40Kgf·cm]
M6	5.88N·m [60Kgf·cm]
M6	8.33N·m [85Kgf·cm]
M8	19.6N·m [200Kgf·cm]
M10	34.3N·m [350Kgf·cm]

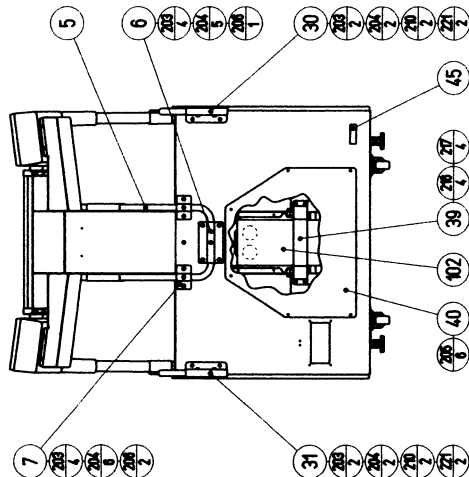
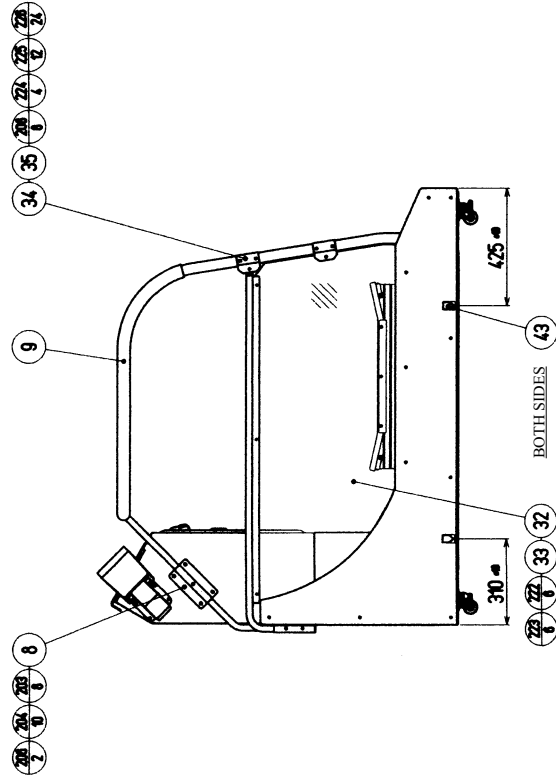
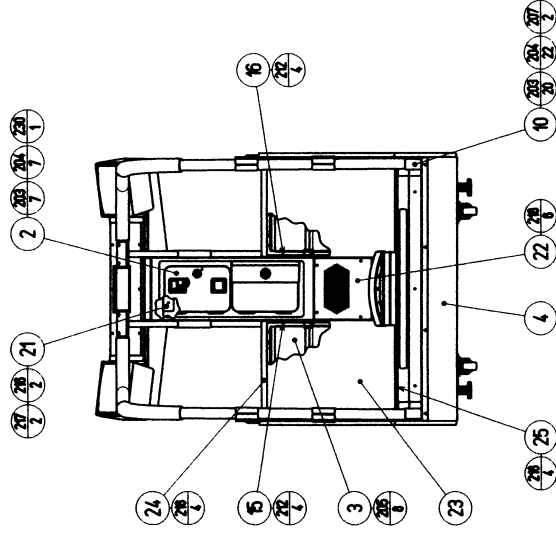
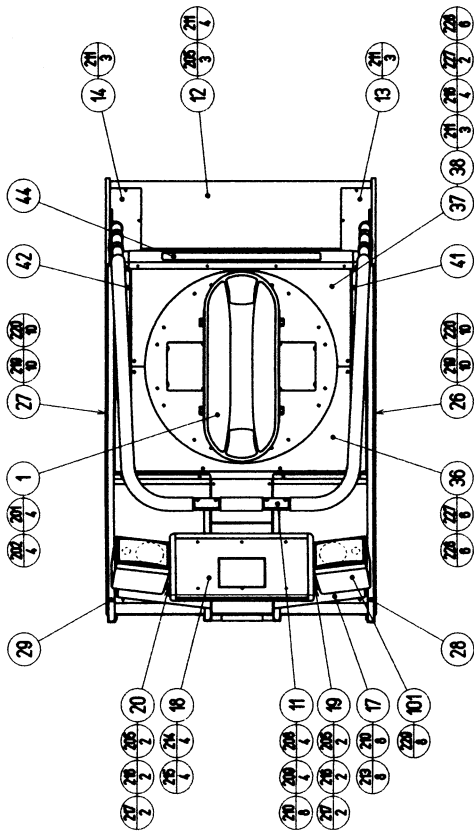

⑫ ASSY REAR CABI (ATR-3000)

(D-2/3)

ITEM NO.	PART NO.	DESCRIPTION	NOTE
1	ATR-3100	ASSY MECHA	
2	ATR-3500	ASSY TOWER	
3	ATR-3600	LAMP UNIT	
4	ATR-3001	REAR FRAME	
5	ATR-3002	SUPPORT PIPE	
6	ATR-3003	PIPE HOLDER FRONT A	
7	ATR-3004	PIPE HOLDER FRONT B	
8	ATR-3005	PIPE HOLDER SIDE	
9	ATR-3006	STAND PIPE	
10	ATR-3007	PIPE HOLDER REAR	
11	ATR-3008	PIPE SUPPORT BRKT	
12	ATR-3009	STEP BRKT	
13	ATR-3010	PIPE LID L	
14	ATR-3011	PIPE LID R	
15	ATR-3012	INNER BOARD L	
16	ATR-3013	INNER BOARD R	
17	ATR-3014	SPEAKER HOLDER	
18	ATR-3015	CNT PANEL	
19	ATR-3016	STAY L	
20	ATR-3017	STAY R	
21	ATR-3018	TOWER BRKT	
22	ATR-3019	BASS BRKT	
23	ATR-3020	LAMP PANEL	
24	ATR-3021	LAMP SASH UPPER	
25	ATR-3022	LAMP SASH LOWER	
26	ATR-3023	SIDE BOARD L	
27	ATR-3024	SIDE BOARD R	
28	ATR-3025	SIDE PIPE L	
29	ATR-3026	SIDE PIPE R	
30	ATR-3027	SIDE PIPE HOLDER L	
31	ATR-3028	SIDE PIPE HOLDER R	
32	ATR-3029	SIDE GUARD PANEL	
33	ATR-3030	SIDE PANEL HOLDER	
34	ATR-3031	SIDE PIPE BRKT A	
35	ATR-3032	SIDE PIPE BRKT B	
36	ATR-3033	FLOOR BOARD FRONT	
37	ATR-3034	FLOOR BOARD REAR	
38	ATR-3035	FLOOR BRKT	
39	ATR-3036	WOOFER HOLDER	
40	ATR-3037	LID REAR	
41	ATR-3038	STICKER REAR FRAME L	
42	ATR-3039	STICKER REAR FRAME R	
43	421-8885	STICKER CAUTION FORK	
101	130-5228	SPEAKER BOX 4OHM 40W	
102	130-5097	SPEAKER BOX SUPER WOOFER	
103	280-5009-01	CORD CLAMP 21	
104	209-0023	CONN CLOSED END	
105	601-0460	PLASTIC TIE BELT 100MM	

⑫ ASSY REAR CABI (ATR-3000)

(D-3/3)

ITEM NO.	PART NO.	DESCRIPTION
201	030-001025-S	HEX BLT W/S M10 X 25
202	068-A52820	FLT WSHR 10.5-28 X 2
203	030-000820-SB	HEX BLT W/S BLK M8 X 20
204	060-F00800-0B	FLT WSHR BLK M8
205	000-P00410-WB	M SCR PH BLK W/FS M4 X 10
206	030-000840-SB	HEX BLT W/S BLK M8 X 40
207	030-000860-SB	HEX BLT W/S BLK M8 X 60
208	031-000650-0C	CRG BLT CRM M6 X 50
209	059-0083	CAP NUT TYPE 3 BLK M6
210	060-F00600-0B	FLT WSHR BLK M6
211	000-T00408-0C	M SCR TH CRM M4 X 8
212	000-P00516-W	M SCR PH W/FS M5 X16
213	030-000616-SB	HEX BLT W/S BLK M6 X 16
214	050-U00500	U NUT M5
215	060-F00500	FLT WSHR M5
216	050-U00400	U NUT M4
217	060-F00400	FLT WSHR M4
218	000-T00408-0B	M SCR TH BLK M4 X 8
219	030-000630-SB	HEX BLT BLK W/S M6 X 30
220	068-652016-0B	FLT WSHR BLK 6.5-20 X 1.6
221	030-000635-SB	HEX BLT BLK M6 X 35
222	000-T00412-0B	M SCR TH BLK M4 X 12
223	050-C00400-3B	CAP NUT TYPE3 BLK M4
224	000-T00620-0C	M SCR TH CRM M6 X 20
225	059-0082	CUP NUT TYPE 3 CRM M6
226	069-0140	FLT WSHR NI M6
227	000-T00425-0B	M SCR TH BLK M4 X 25
228	068-441616-0B	FLT WSHR BLK 4.4-16 X 1.6
229	012-P00512-0B	TAP SCR #2 PH BLK 5 X 12
230	008-T00412-0B	TMP PRF SCR TH BLK M4 X 12
301	ATR-6002	ASSY WIRE REAR CABI
302	ATR-60081	WH WOOFER

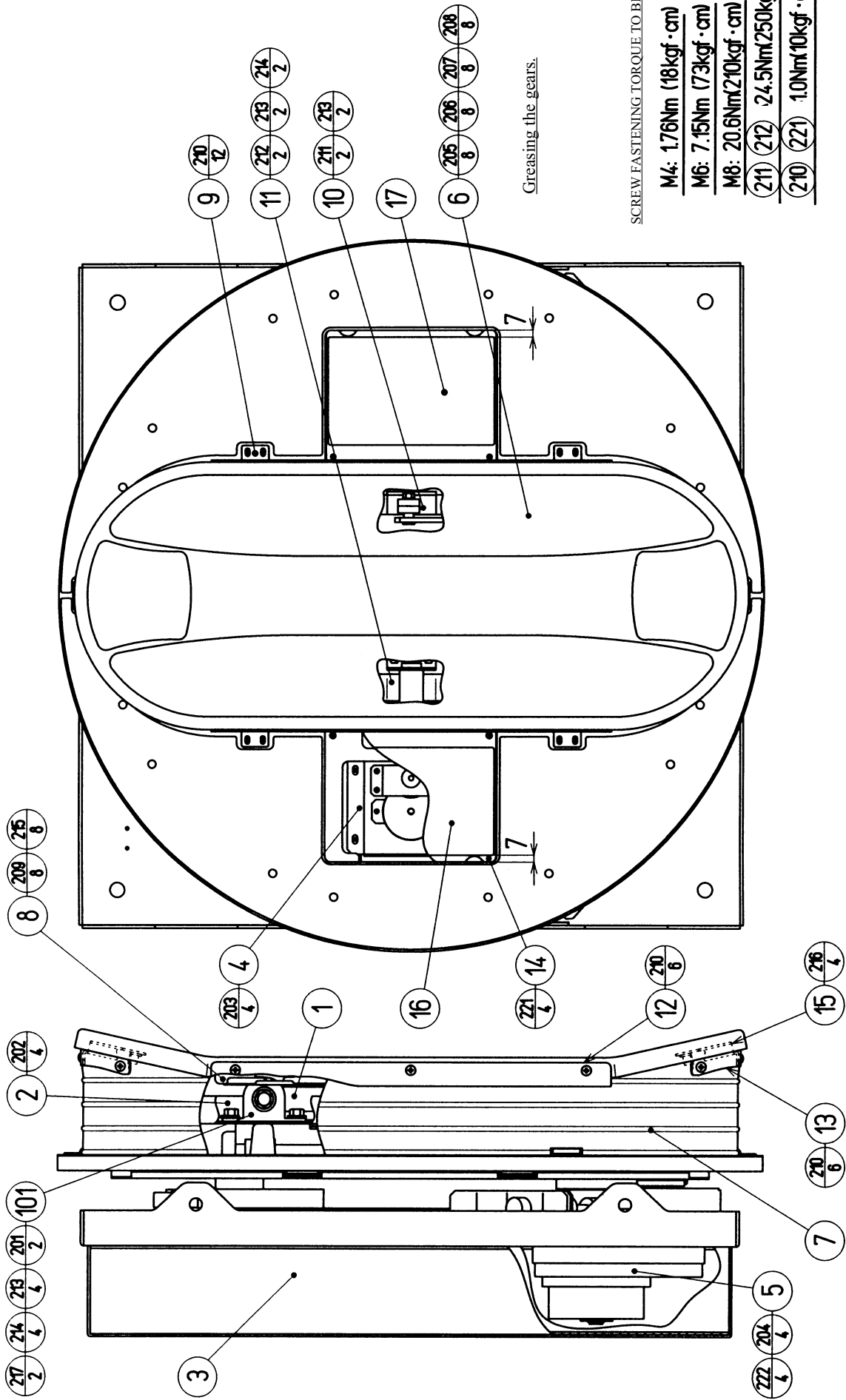

Greasing the gears.

SCREW FASTENING TORQUE TO BE

M4:	1.76Nm	(18kgf·cm)
M6:	7.15Nm	(73kgf·cm)
M8:	20.6Nm	(210kgf·cm)
(211)	(212)	(24.5Nm/250kgf·cm)
(210)	(221)	(1.0Nm/10kgf·cm)

13 ASSY MECHA (ATR-3100)

(D-2/2)

ITEM NO.	PART NO.	DESCRIPTION	NOTE
1	ATR-3150	ASSY BOARD	
2	ATR-3200	ASSY ROLLING BASE	
3	ATR-3250	ASSY SWING MECHA	
4	ATR-3300	YAWING SENSOR UNIT	
5	ATR-3350	BRAKE UNIT	
6	ATR-3101	BOARD	
7	ATR-3102	BELLOWS	
8	ATR-3103	SIDE BELLOWS BRKT	
9	ATR-3104	BELLOWS HOLDER	
10	ASL-3105	HOOK	
11	ASL-3106	STOPPER UPPER HOLDER	
12	ATR-3107	SIDE BELLOWS SASH	
13	ATR-3108	END BELLOWS SASH	
14	ATR-3109-A	TABLE LID BLANK	
15	ATR-3110	BELLOWS END BRKT	
16	ATR-3109-B	STICKER TABLE LID L	
17	ATR-3111-B	STICKER TABLE LID R	
101	100-5302	BEARING 15	
102	280-5009-01	CORD CLAMP 21	
103	280-5275-SR10	CORD CLAMP SR10	
104	601-0460	PLASTIC TIE BELT 100MM	
201	030-000816-S	HEX BLT W/S M8 X 16	
202	030-000816-W	HEX BLT W/FS M8 X 16	
203	000-P00408-W	M SCR PH W/FS M4 X 8	
204	030-000825-S	HEX BLT W/S M8 X 25	
205	031-000620-0B	CRG BLT BLK M6 X 20	
206	060-F00600	FLT WSHR M6	
207	060-S00600	SPR WSHR M6	
208	050-H00600	HEX NUT M6	
209	000-T00410-0B	M SCR TH BLK M4 X 10	
210	000-P00412-WB	M SCR PH W/FS BLK M4 X 12	
211	FAS-200014	HEX SKT H CAP SCR BLK OZ M8 X 45	
212	020-000825-0Z	HEX SKT H CAP SCR BLK OZ M8 X 25	
213	060-S00800	SPR WSHR M8	
214	050-H00800	HEX NUT M8	
215	050-H00400	HEX NUT M4	
216	000-P00410-W	M SCR PH W/FS M4 X 10	
217	068-852216	FLT WSHR 8.5-22 X 1.6	
218	060-F00400	FLT WSHR M4	
219	060-S00400	SPR WSHR M4	
220	000-P00408	M SCR PH M4 X 8	
221	000-P00420-WB	M SCR PH W/FS BLK M4 X 20	
222	DYN-1019	FLT WASHER M8	
301	ATR-60051	WH BOARD	
302	ATR-60052	WH BRAKE	
303	ATR-60053X	WH EXT SWING VOL	
306	ATR-60103	WH EARTH BOARD TUBE	

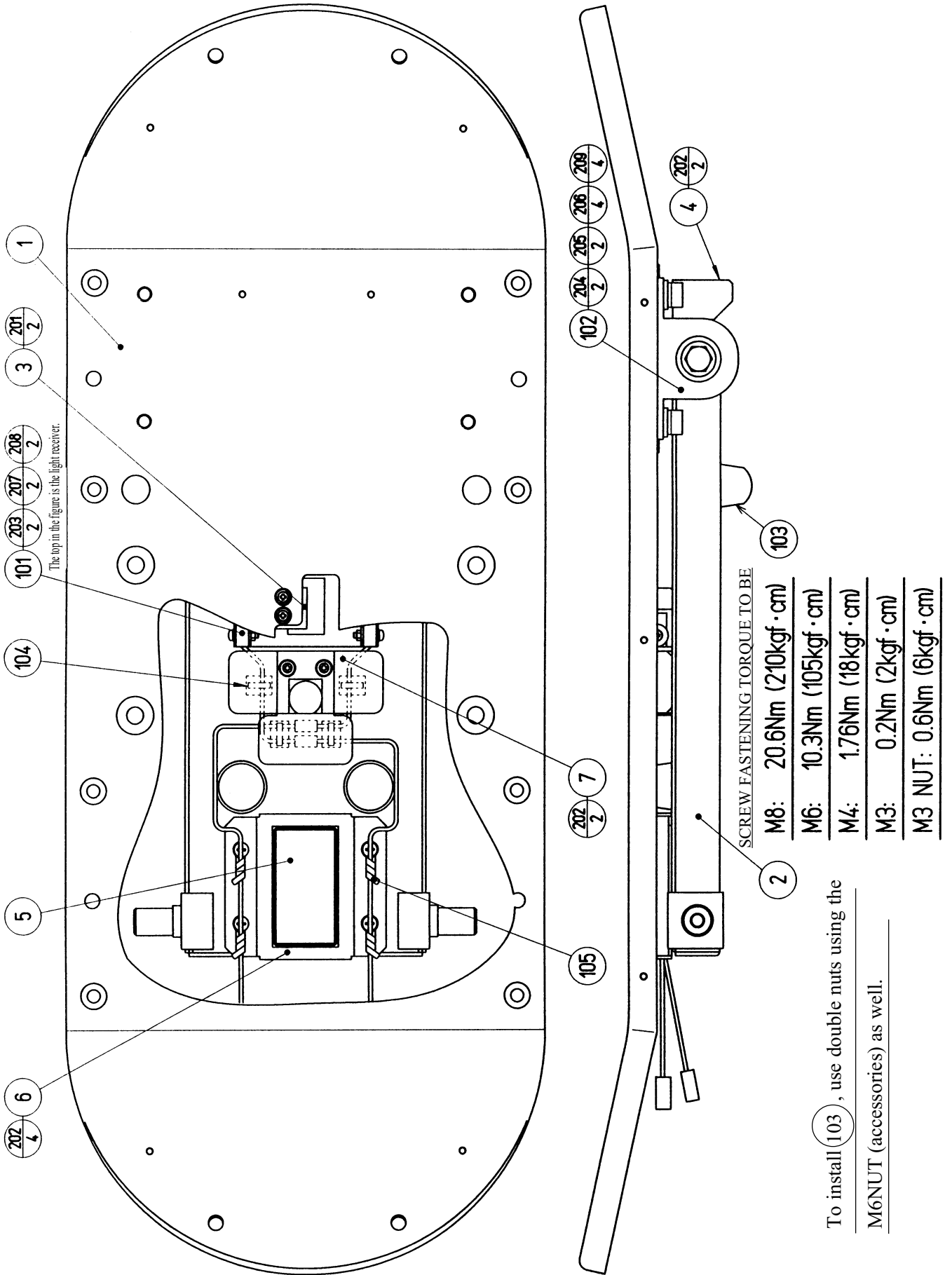

⑭ ASSY BOARD (ATR-3150)

(D-2/2)

ITEM NO.	PART NO.	DESCRIPTION
1	ATR-3151	BOARD BASE
2	ATR-3152	UPPER BASE
3	ASL-3153	SW PLATE A
4	ATR-3154	SW PLATE B
5	ATR-3155	STOPPER B
6	ATR-3156	STOPPER BRKT B
7	ATR-3157	WIRE COVER
101	370-5232-01	PHOTO SENSOR OMT-01L-SS
102	100-5302	BEARING 15
103	601-5564	STOPPER
104	280-5275-SR10	CORD CLAMP SR10
105	280-5207	HARNESS LUG CC-1005
201	000-P00308-W	M SCR PH W/FS M3 X 8
202	000-P00408-W	M SCR PH W/FS M4 X 8
203	000-P00314-S	M SCR PH W/S M3 X 14
204	030-000816-S	HEX BLT W/S M8 X 16
205	068-852216	FLT WSHR 8.5-22 X 1.6
206	020-000820-OZ	HEX SKT H CAP SCR BLK OZ M8 X 20
207	250-5421	FLT WSHR 3.5-12 T=1.0
208	050-H00300	HEX NUT M3
209	060-S00800	SPR WSHR M8
301	ATR-60061	WH PHOT FRONT

15) ASSY ROLLING BASE (ATR-3200)

(D-1/2)

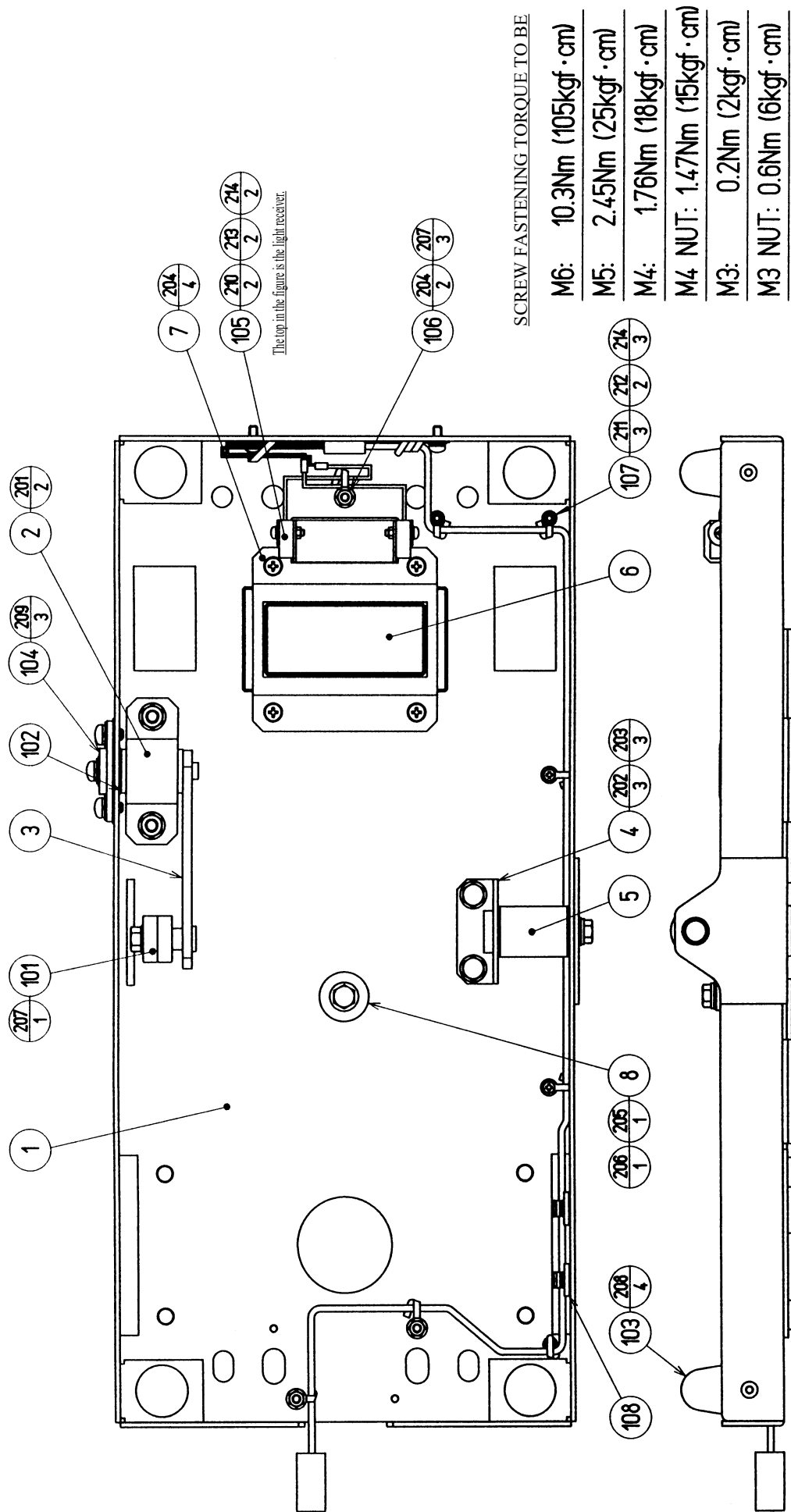

To install (103), use double nuts using the
M6NUT (accessories) as well.

15) ASSY ROLLING BASE (ATR-3200)

(D-2/2)

ITEM NO.	PART NO.	DESCRIPTION
1	ATR-3201X	ROLLING BASE
2	ASL-3204	UPPER ROSTA HOLDER
3	ATR-3205	ROSTA ARM
4	ASL-3206X	HOLDER UPPER
5	ASL-3207	STOPPER UPPER
6	ASL-3208	STOPPER A
7	ATR-3209X	STOPPER BRKT A
8	ASL-3210	SWING STOPPER RUBBER
101	100-5018	BEARING BALL 8
102	601-9354	ROSTA
103	601-5564	STOPPER
104	100-5386	BEARING 10
105	370-5232-01	PHOTO SENSOR OMT-01L-SS
106	280-5207	HARNESS LUG CC-1005
107	280-5288	HARNESS LUG CC-1003
108	280-6632	CORD CLAMP MSC-2
201	050-F00600	FLG NUT M6
202	030-000616-S	HEX BLT W/S M6 X 16
203	060-F00600	FLT WSHR M6
204	000-P00408-W	M SCR PH W/FS M4 X 8
205	030-000612-S	HEX BLT W/S M6 X 12
206	068-652016	FLT WSHR 6.5-20 X 1.6
207	050-F00400	FLG NUT M4
208	050-H00600	HEX NUT M6
209	000-P00510-W	M SCR PH W/FS M5 X 10
210	000-P00314-S	M SCR PH W/S M3 X 14
211	060-S00300	SPR WSHR M3
212	000-P00308-W	M SCR PH W/FS M3 X 8
213	250-5421	FLT WSHR 3.5-12 T=1.0
214	050-H00300	HEX NUT M3
301	ATR-60062	WH PHOT REAR
302	600-6897-073	WIRE HARN FRONT SENSOR

16 ASSY SWING MECHA (ATR-3250)

(D-1/3)

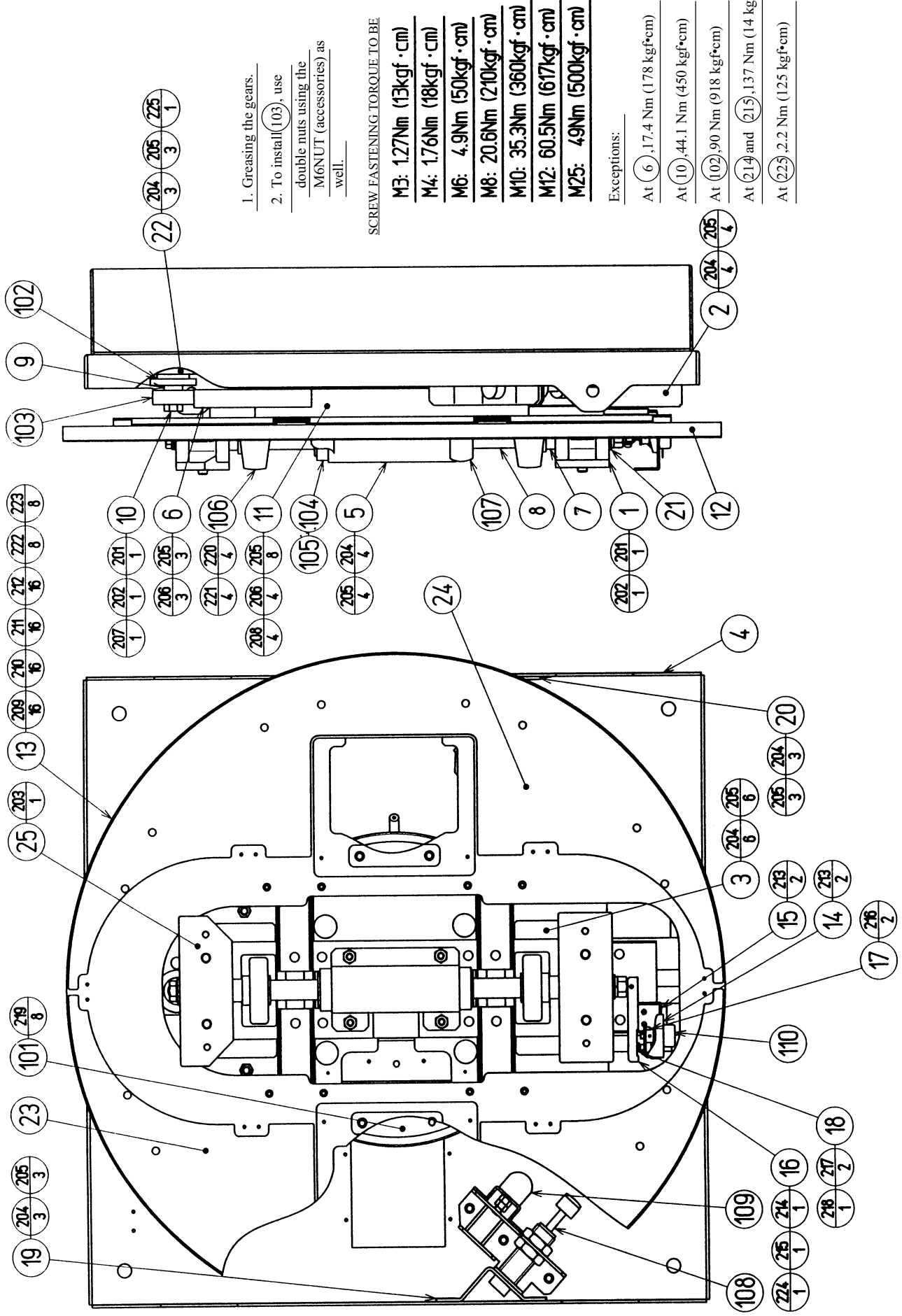

1. Greasing the gears.
2. To install (103), use double nuts using the M6NUT (accessories) as well.

SCREW FASTENING TORQUE TO BE

M3:	1.27Nm (13kgf·cm)
M4:	1.76Nm (18kgf·cm)
M6:	4.9Nm (50kgf·cm)
M8:	20.6Nm (210kgf·cm)
M10:	35.3Nm (360kgf·cm)
M12:	60.5Nm (617kgf·cm)
M25:	4.9Nm (500kgf·cm)

Exceptions:

At (6)	17.4 Nm (178 kgf·cm)
At (10)	44.1 Nm (450 kgf·cm)
At (102)	90 Nm (918 kgf·cm)
At (214) and (215)	137 Nm (14 kgf·cm)
At (225)	2.2 Nm (12.5 kgf·cm)

16 ASSY SWING MECHA (ATR-3250)

(D-2/3)

ITEM NO.	PART NO.	DESCRIPTION
1	ASL-3251	MOUNT BLOCK
2	ATR-3252	STOP BASE
3	ATR-3253	SWING BASE
4	ATR-3254X	MECHA BASE
5	ATR-3255	ROLL ROSTA HOLDER
6	ATR-3256	CENTERING CAM
7	ATR-3257X	ROLL COLLAR
8	ATR-3258	ROLL SHAFT
9	ATR-3259	FOLLOWER COLLAR
10	ATR-3260X	FOLLOWER SHAFT
11	ATR-3261	TABLE FRAME
12	ATR-3262	TURN TABLE
13	ATR-3263-A	TURN PLATE BLANK
14	ATR-3264	ROLL VR HOLDER
15	ATR-3265	ROLL VR BRKT
16	ATR-3266	PIN GUIDE
17	ATR-3267	PIN CRANK
18	ATR-3268	ROLL PIN
19	ATR-3269	STOPPER BRKT L
20	ATR-3270	STOPPER BRKT R
21	ASL-3308	SPL WASHER M12
22	ATR-3271	CENTERING FIXER
23	ATR-3263-B	STICKER TURN PLATE L
24	ATR-3263-C	STICKER TURN PLATE R
25	ATR-3251	MOUNT BLOCK ATR
101	100-5388	TURN BEARING 336
102	601-11016	ROSTA SE-27
103	100-5387	ROLLER 15
104	601-8458	ROSTA 22 DR-S27X100
105	601-8596	ROSTA 22
106	100-5274	BEARING 20
107	601-5564	STOPPER
108	601-11019	SHOCK ABSORBER FK-2525-C-SE4
109	601-11005	STOPPER RI-30HD
110	220-5484	VOL CONT B-5K OHM
111	280-5008	CORD CLAMP 15
112	280-5009-01	CORD CLAMP 21
113	280-5169	CORD CLAMP TL-20S
114	280-5275-SR10	CORD CLAMP SR10
115	310-5029-F20	SUMITUBE F F 20MM

①6 ASSY SWING MECHA (ATR-3250)

(D-3/3)

ITEM NO.	PART NO.	DESCRIPTION
201	050-H01200	HEX NUT M12
202	060-S01200	SPR WSHR M12
203	FAS-300015	HEX BLT W/S M12 X 20
204	030-000820-S	HEX BLT W/S M8 X 20
205	060-F00800	FLT WSHR M8
206	030-000830-S	HEX BLT W/S M8 X 30
207	060-F01200	FLT WSHR M12
208	030-000850-S	HEX BLT W/S M8 X 50
209	031-000625-0B	CRG BLT BLK M6 X 25
210	060-F00600	FLT WSHR M6
211	060-S00600	SPR WSHR M6
212	050-H00600	HEX NUT M6
213	000-P00408-W	M SCR PH W/FS M4 X 8
214	000-P00418-W	M SCR PH W/FS M4 X 18
215	050-H00400	HEX NUT M4
216	028-C00306-P	SET SCR CH CUP P M3 X 6
217	060-F00300	FLT WSHR M3
218	065-E00200	E RING 2MM
219	030-000840-S	HEX BLT W/S M8 X 40
220	FAS-290002	HEX SKT SCR BH BLK M10 X 16
221	060-S01000	SPR WSHR M10
222	030-000625-S	HEX BLT W/S M6 X 25
223	068-652016	FLT WSHR 6.5-20 X 1.6
224	000-P00406-W	M SCR PH W/FS M4 X 6
225	030-000870-S	HEX BLT W/S M8 X 70
301	ATR-60060	WH ROLL VOL

①⑦ YAWING SENSOR UNIT (ATR-3300)

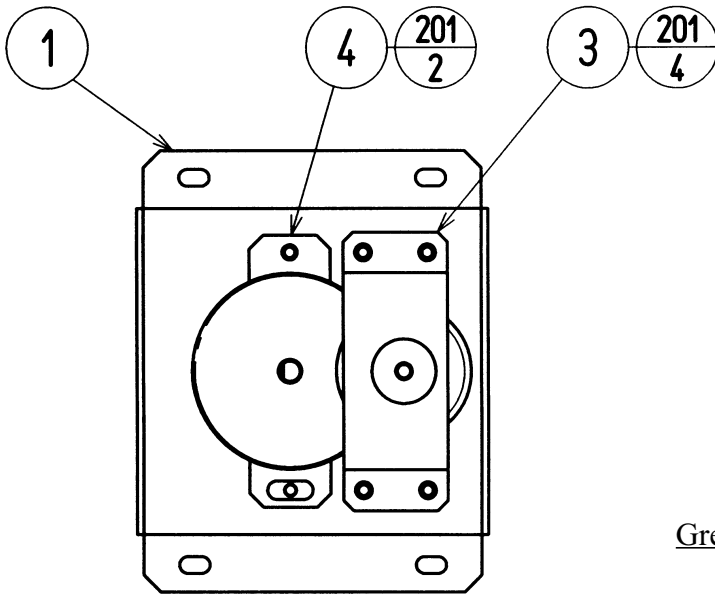

Greasing the gears.

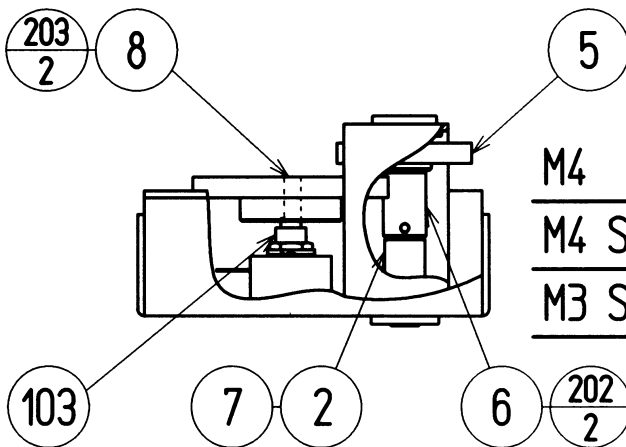

SCREW FASTENING TORQUE TO BE

M4	1.76N·m(18kgf·cm)
M4 SET SCR	2.45N·m(25kgf·cm)
M3 SET SCR	1.27N·m(13kgf·cm)

ITEM NO.	PART NO.	DESCRIPTION
1	ATR-3301	YAW SENSE BOX
2	ATR-3302	REDUCTION SHAFT
3	ATR-3303	SHAFT HOLDER
4	ATR-3304	YAW VOL HOLDER
5	ATR-3305	GEAR 18 M2
6	ATR-3306	GEAR 15 M0.75
7	ATR-3307	KEY 2 X 2 X 24
8	601-6296-91	GEAR 75B
103	220-5484	VOL CONT B-5K OHM
104	280-0419	HARNESS LUG
105	310-5029-F20	SUMITUBE F F 20MM
201	000-P00408-W	M SCR PH W/FS M4 X 8
202	028-C00306-P	SET SCR CH CUP P M3 X 6
203	028-C00416-P	SET SCR CH CUP P M4 X 16
301	ATR-60050	WH SWING VOL

⑱ BRAKE UNIT (ATR-3350)

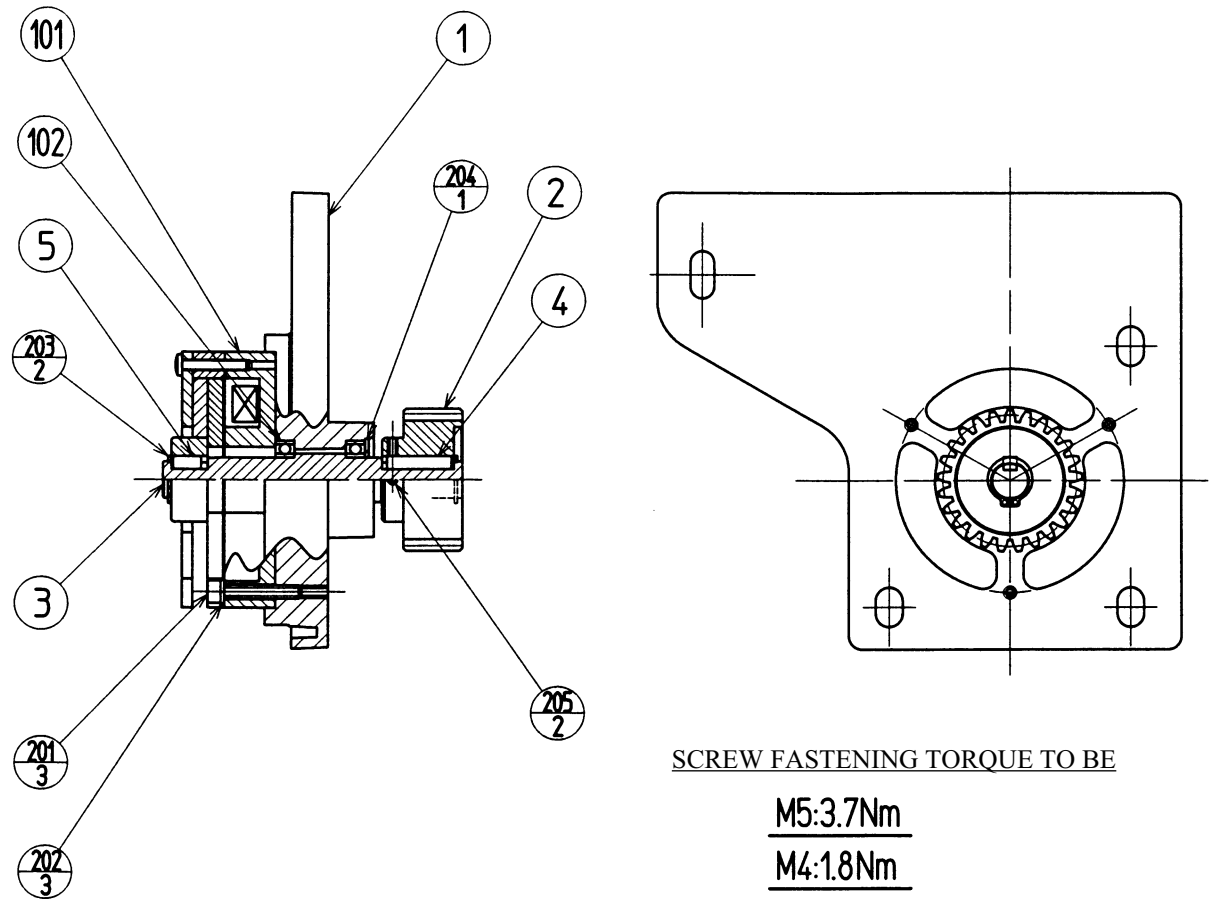

ITEM NO.	PART NO.	DESCRIPTION
1	ATR-3351	BRAKE BASE
2	ASL-3352	PINION GEAR 25
3	ATR-3353	BRAKE SHAFT
4	ASL-3354	KEY 5 X 5 X 24
5	ASK-3606	KEY 5 X 5-10.5
101	601-10806	BRAKE BXH-08
102	100-5229	BEARING 17
201	020-000530-0Z	HEX SKT H CAP SCR BLK OZ M5 X 30
202	060-S00500	SPR WSHR M5
203	065-S014S0-Z	STP RING BLK OZ S14
204	065-A030H0-Z	STP RING BLK OZ H30
205	028-A00408-P	SET SCR HEX SKT CUP P M4 X 8

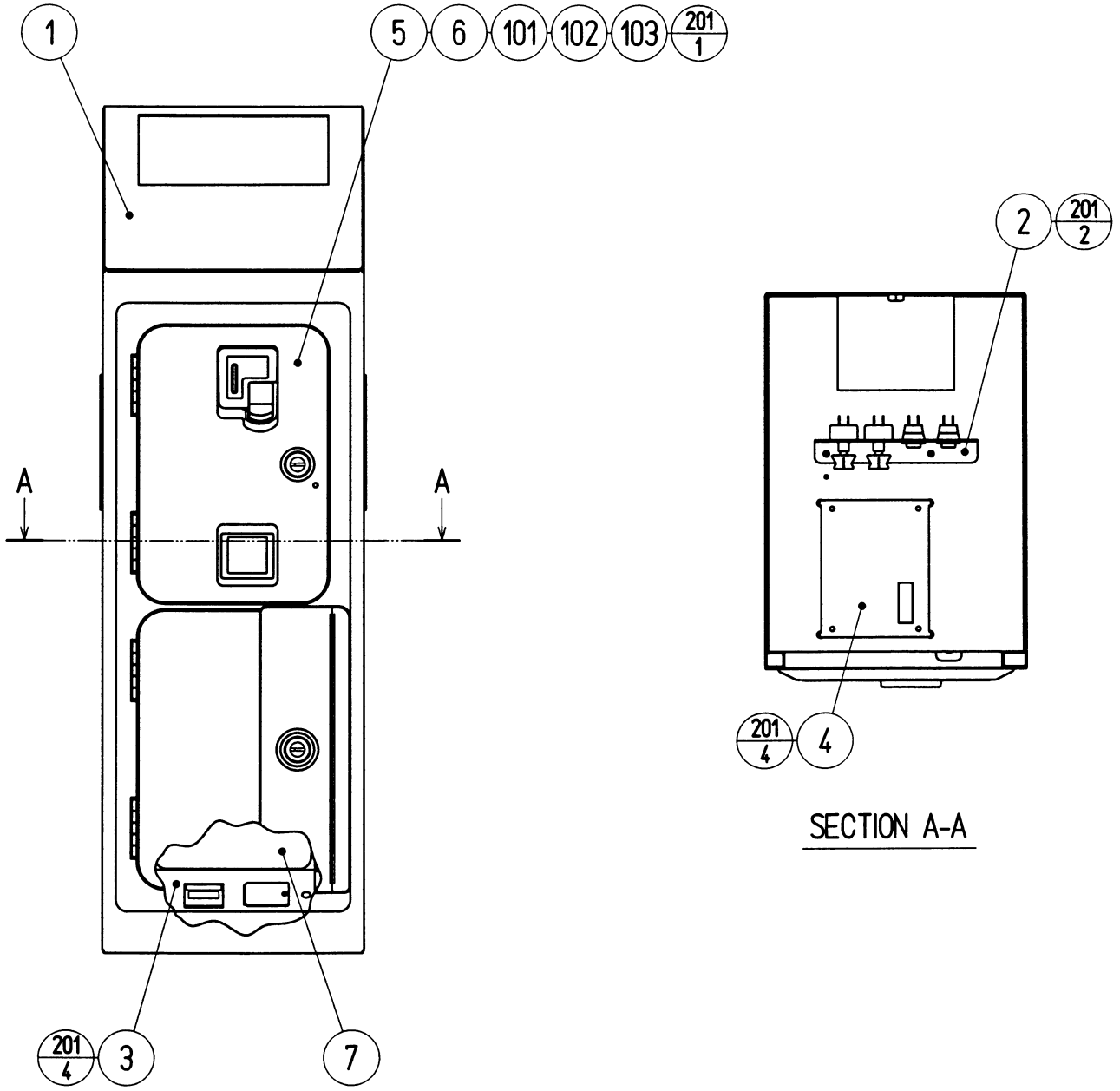

①9 ASSY TOWER (ATR-3500)

(D-2/2)

ITEM NO.	PART NO.	DESCRIPTION	NOTE
1	ATR-3501	COIN CHUTE TOWER	
2	INY-1180	SW UNIT	
3	ATR-3550	METER UNIT	
4	105-5171	CHUTE PLATE SINGLE	OTHERS
	105-5172	CHUTE PLATE DOUBLE	USA
5	DP-1167	TNG LKG	OTHERS
		Locally supplied.	USA
6	421-7501-02	STICKER 6.3V 0.15A	OTHERS
		Locally supplied.	USA
7	253-5366	CASH BOX	
101	220-5237-92- ~ 220-5482-91- ~	ASSY C.C 2DR ~ ASSY C.C 2DR ~ Locally supplied.	OTHERS HONG KONG,KOREA,TAIWAN USA
102	220-5575	CAM LOCK MASTER W/O KEY Locally supplied.	OTHERS USA
103	220-5574	CAM LOCK W/KEYS Locally supplied.	OTHERS USA
104	310-5029-F20	SUMITUBE F F 20MM Locally supplied.	OTHERS USA
105	280-5009-01	CORD CLAMP 21	
106	280-5275-SR10	CORD CLAMP SR10	
107	280-5008	CORD CLAMP 15	
108	601-0460	PLASTIC TIE BELT 100MM	
201	000-P00408-W	M SCR PH W/FS M4 X 8	
202	000-P00408	M SCR PH M4 X 8	
203	060-S00400	SPR WSHR M4	
204	060-F00400	FLT WSHR M4	
301	600-6455-02	WIRE HARN C.C DOOR SINGLE Locally supplied.	OTHERS USA
302	600-7237-0150	WH EARTH VD2-5&VD1.25-4 150MM	
303	600-7237-0250	WH EARTH VD2-5&VD1.25-4 250MM	
304	ATR-60070	WH SPEAKER TOWER	
305	ATR-60071	WH COIN TOWER	
306	ATR-60072	WH EXT CONT PNL TOWER	

② SW UNIT (INY-1180)

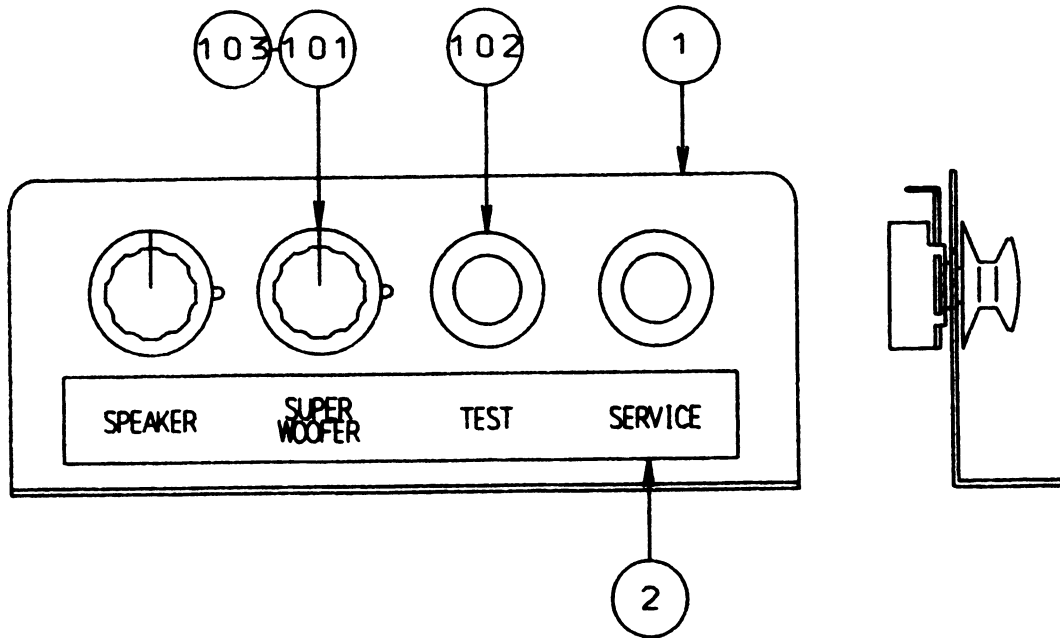

ITEM NO.	PART NO.	DESCRIPTION
1	INY-1181	SW BRKT
2	421-8911	STICKER SW UNIT
101	220-5179	VOL CONT B-5K OHM
102	509-5028	SW PB 1M
103	601-0042	KNOB 22 MM
104	310-5029-D20	SUMITUBE F D 20 MM
105	601-0460	PLASTIC TIE BELT 100 MM
301	600-6609-32	WIRE HARN TEST & SERVICE
302	600-6609-33	WIRE HARN VOLUME A
303	600-6609-34	WIRE HARN VOLUME B

②① METER UNIT (ATR-3550)

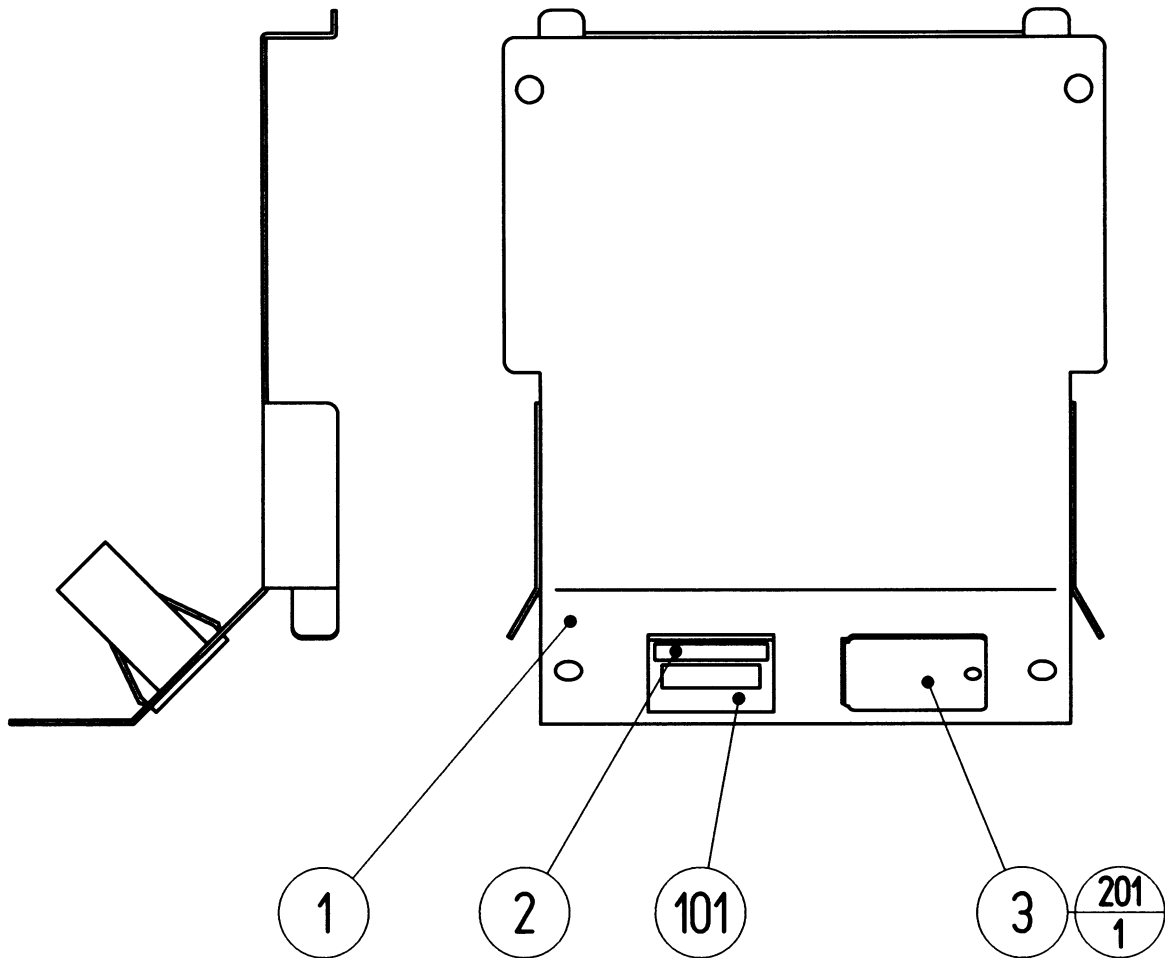

ITEM NO.	PART NO.	DESCRIPTION	NOTE
1	ATR-3551	METER BRKT	
2	421-9168-01	STICKER COIN METER	
3	HOT-1007	LID COIN CNTR	OTHERS USA
101	220-5643-01	MAG CNTR DC5V 6P WH MZ-674-D04	OTHERS
	220-5617-02	MAG CNTR DC5V W/CONN 6P YE	USA
	220-5643-02	MAG CNTR DC5V 6P YE MZ-674-D05	USA
102	280-5275-SR10	CORD CLAMP SR10	
201	000-P00308-W	M SCR PH W/FS M3 X 8	OTHERS USA
		NOT USED	

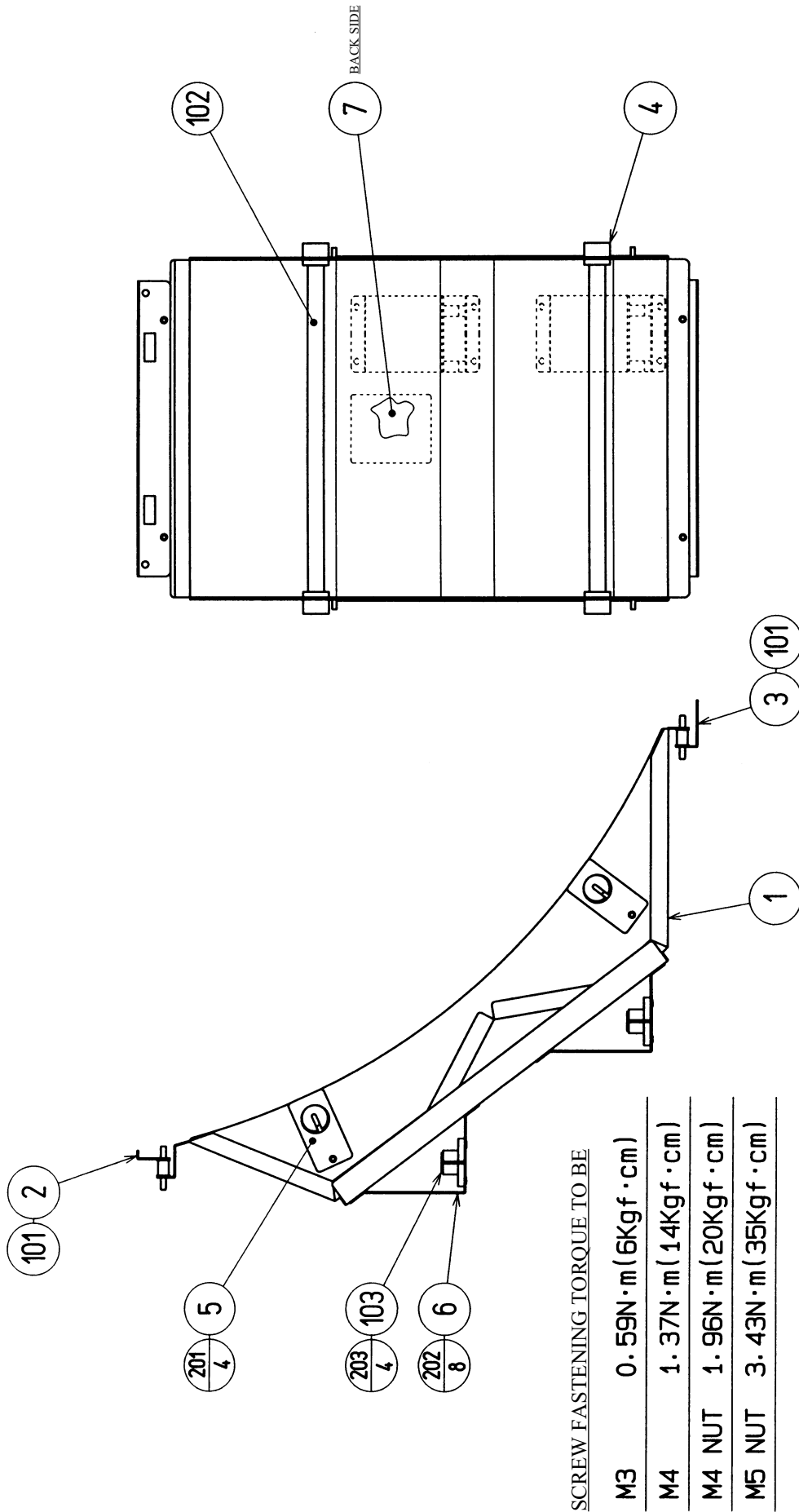

② LAMP UNIT (ATR-3600)

(D-2/2)

ITEM NO.	PART NO.	DESCRIPTION
1	ATR-3601	LAMP BASE
2	ATR-3602	DAMPER BRKT UPPER
3	ATR-3603	DAMPER BRKT LOWER
4	ATR-3604	LAMP HOLDER
5	ATR-3605	HOLDER BRKT
6	ATR-3606	INVERTER BRKT
7	440-WS0002XEG	STICKER W POWER OFF ENG
101	601-8288	RUBBER DUMPER
102	390-6697-BL	CCFL TUBE W/PIPE L=330 BLUE
103	838-14010-01	CCFL INV S-12617C-7M W/L
104	280-5275-SR10	CORD CLAMP SR10
105	280-5009-01	CORD CLAMP 21
106	270-5052-04	L.FILTER D
107	601-0460	PLASTIC TIE BELT 100MM
201	050-F00400	FLG NUT M4
202	000-P00408-W	M SCR PH W/FS M4 X 8
203	000-P00310-W	M SCR PH W/FS M3 X 10
301	ATR-60082	WH LAMP

②③ ASSY SW PANEL (ATR-3700)

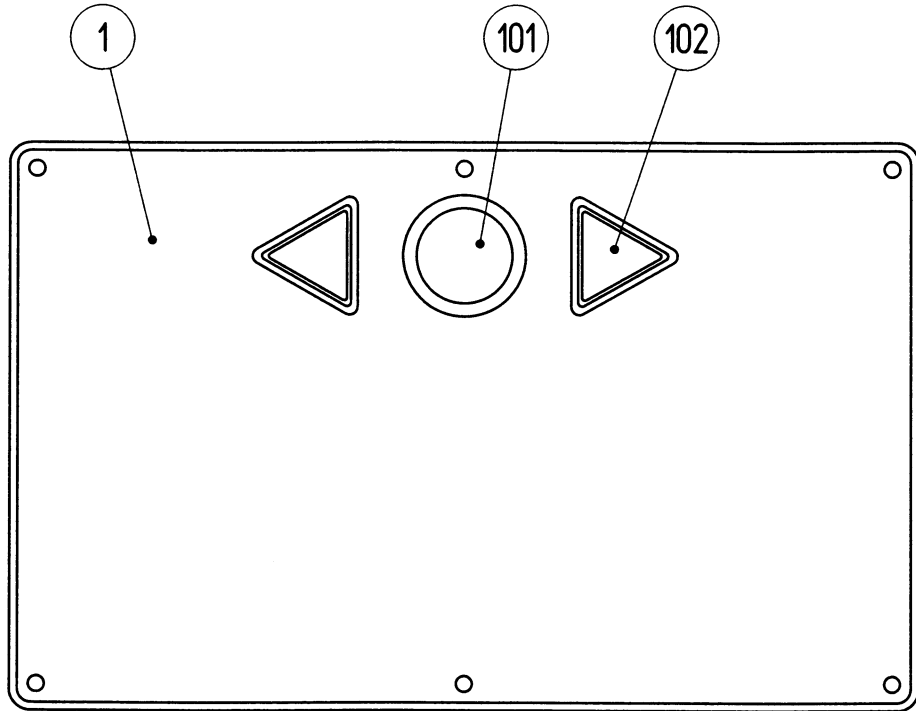

ITEM NO.	PART NO.	DESCRIPTION
1	ATR-3701	SW PLATE
101	509-5712-04	SW PB W/L 6V ORANGE
102	509-5499-03-LN	SW PB TRIANGLE YELLOW W/O LAMP
103	601-0460	PLASTIC TIE BELT 100MM
301	ATR-60080	WH CONT PNL

②④ ASSY MAIN BD (ATR-4000)

(D-1/2)

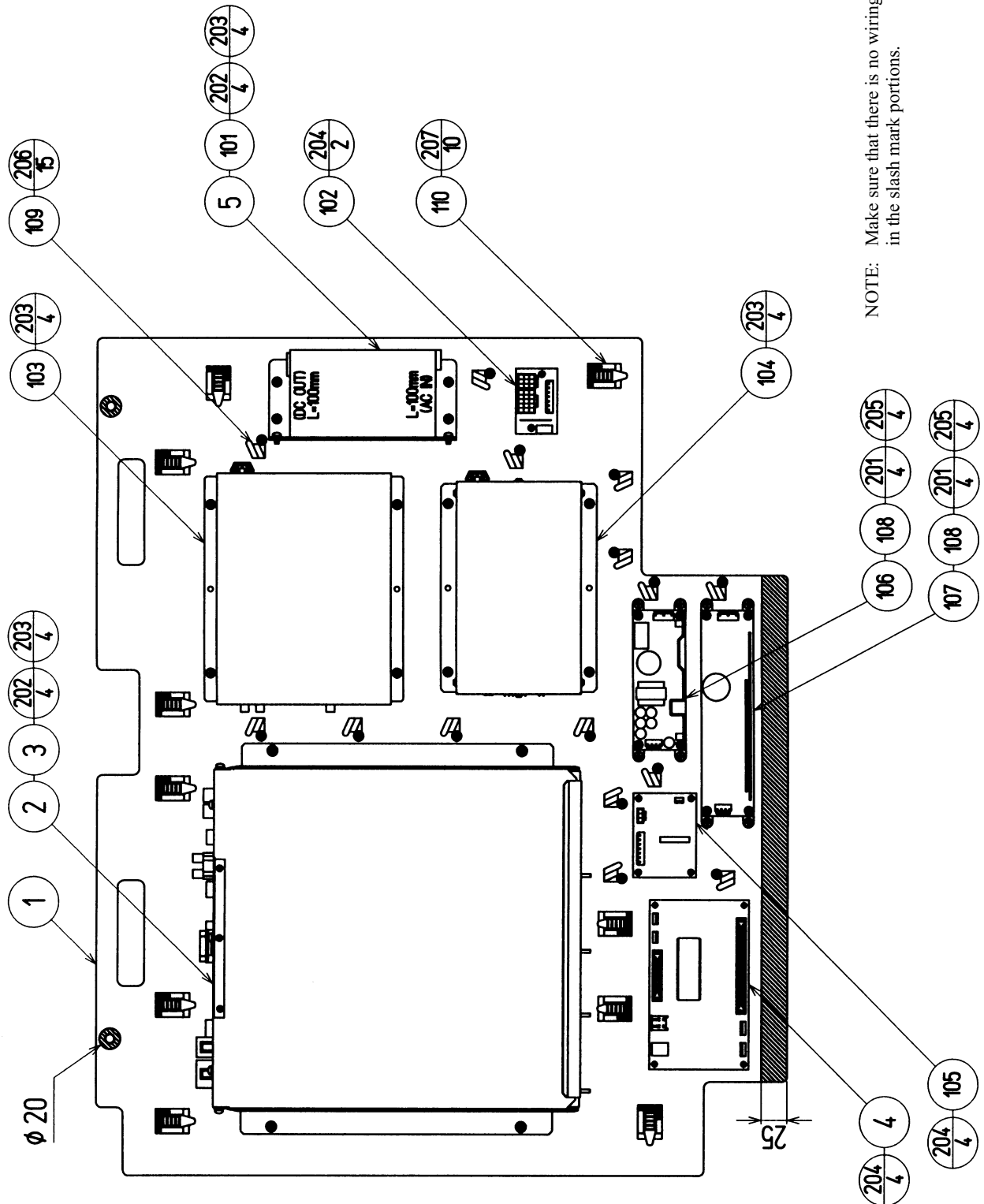

NOTE: Make sure that there is no wiring, etc. in the slash mark portions.

24 ASSY MAIN BD (ATR-4000)

(D-2/2)

ITEM NO.	PART NO.	DESCRIPTION
1	ATR-4001	WOODEN BASE
2	ATR-4050	ASSY SHILD CASE ATR
3	105-5382	SHIELD CASE BRKT
4	837-13551-92	I/O CONTROL BD FOR JVS
5	APC-4002	SW REGU BRKT
101	400-5397-01	SW REGU FOR JVS VA
102	838-11856-UL	CONNECT BD UL
103	601-10369	STEREO PWR AMP 47
104	610-0609	LOWPASS AMP 40HM 30W
105	839-1073-03	SSR BD 1 DC 2A
106	400-5421-03024	SW REGU LCA30S-24
107	400-5421-05012	SW REGU LCA50S-12
108	601-7467	L-LOCK BK
109	280-0419	HARNESS LUG
110	280-5009-01	CORD CLAMP 21
111	601-0460	PLASTIC TIE BELT 100MM
112	270-5117	FERRITE CORE TDK ZCAT3035-1330
201	000-P00308-W	M SCR PH W/FS M3 X 8
202	000-P00408-W	M SCR PH W/FS M4 X 8
203	000-P00416-W	M SCR PH W/FS M4 X 16
204	011-P00325	TAP SCR PH 3 X 25
205	011-T03516	TAP SCR TH 3.5 X 16
206	011-T03512	TAP SCR TH 3.5 X 12
207	011-F00316	TAP SCR FH 3 X 16
301	ATR-60001	WH CONN BD AC IN
302	ATR-60002	WH AC OUT 15P
303	ATR-60003	WH AC OUT 9P
304	ATR-60004	WH EXT DC MAIN BD
305	ATR-60005	WH VOL AND SOUND
306	ATR-60006	WH CENTER LINE
307	ATR-60007	WH SOUND LINE
308	ATR-60010	WH A/D
309	ATR-60011	WH I/O
310	ATR-60012	WH DC24V
311	ATR-60013	WH BRAKE OUT
312	600-7141-100	CABLE JVS TYPE A-B 100CM
313	600-7159-070	WIRE HARN JVS PWR 070CM

②⑤ ASSY SHIELD CASE ATR (ATR-4050)

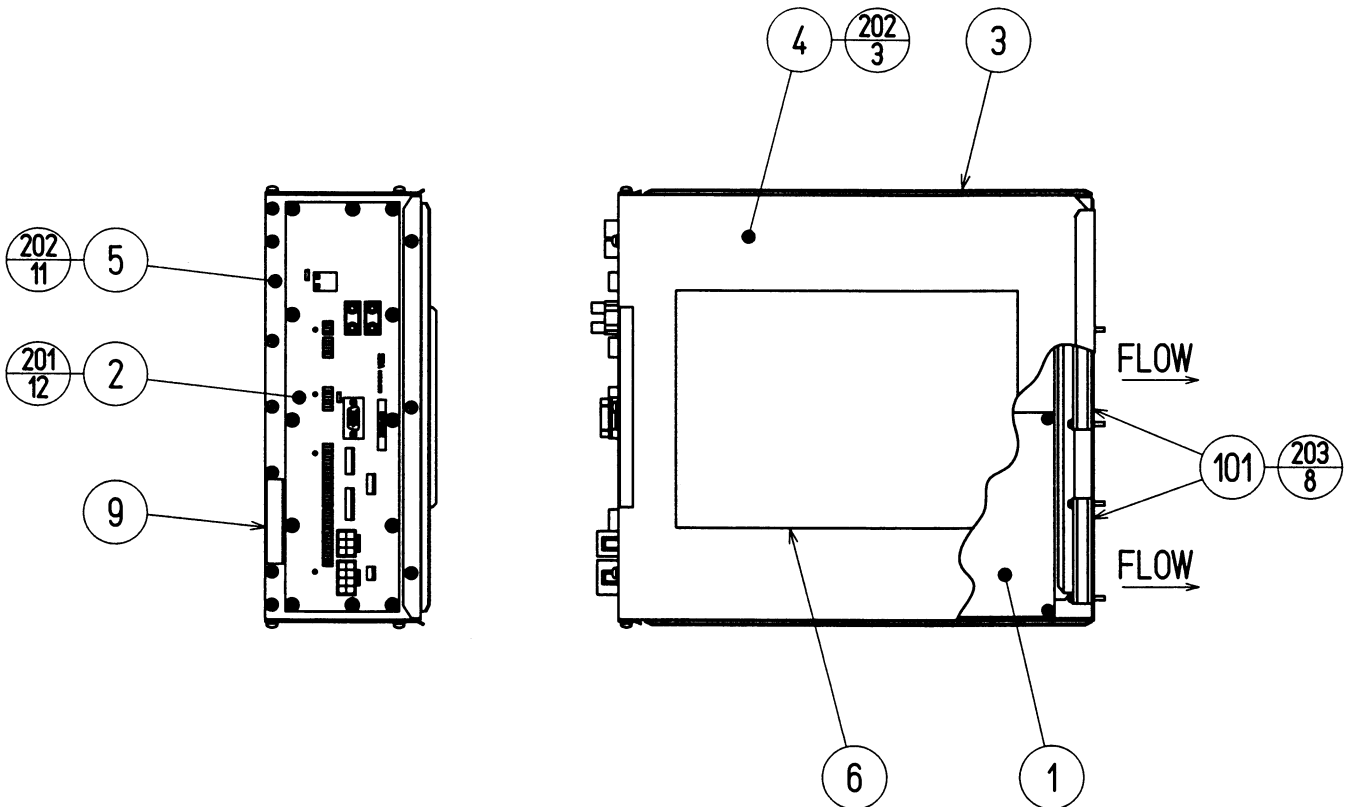

ITEM NO.	PART NO.	DESCRIPTION
1	833-14150	GAME BD ATR
2	839-1079-01	FLT BD SEGA HIKARU FRQ
3	105-5378	SHIELD CASE FOR SEGA HIKARU
4	105-5379	SHIELD CASE LID FOR SEGAHIKARU
5	105-5381	FLT BD BRKT FOR SEGA HIKARU
6	421-9174	STICKER CAUTION ANTISTATIC
7	421-10023-AAB	STICKER BD SERIAL NUMBER AAB
8	421-10023-BCO	STICKER BD SERIAL NUMBER BCO
9	441-314150	STICKER 833-14150
10	601-10642	CARTON BOX SEGA HIKARU
101	260-0064	FAN MOTOR DC12V
102	280-5275-SR10	CORD CLAMP SR10
201	010-P00310-F	S-TITE SCR PH W/F M3 X 10
202	000-P00408-W	M SCR PH W/FS M4 X 8
203	000-P00325-W	M SCR PH W/FS M3 X 25
301	FRQ-60037	WIRE HARN FAN SHIELD CASE

②⑥ ASSY WIRE FRONT CABI (ATR-6001)

ASSY WIRE FRONT CABI (ATR-6001) is comprised of the following wire harnesses.
An ASSY DRG. is unavailable.

ITEM NO.	PART NO.	DESCRIPTION
101	601-0460	PLASTIC TIE BELT 100MM
301	ATR-60024	WH EXT COIN FRONT
302	ATR-60025	WH EXT INTERFACE FRONT
303	ATR-60026	WH EXT BRAKE FRONT
304	ATR-60027	WH EXT CONT PNL FRONT
305	ATR-60028	WH EXT LAMP FRONT

②⑦ ASSY WIRE REAR CABI (ATR-6002)

ASSY WIRE REAR CABI (ATR-6002) is comprised of the following wire harnesses.
An ASSY DRG. is unavailable.

ITEM NO.	PART NO.	DESCRIPTION
101	601-0460	PLASTIC TIE BELT 100MM
301	ATR-60040	WH EXT LAMP REAR
302	ATR-60041	WH EXT COIN REAR
303	ATR-60042	WH EXT CONT PNL REAR
304	ATR-60043	WH EXT SPEAKER REAR
305	ATR-60044	WH EXT INTERFACE REAR

②⑧ ASSY TRANS EXP (JEY-4200)

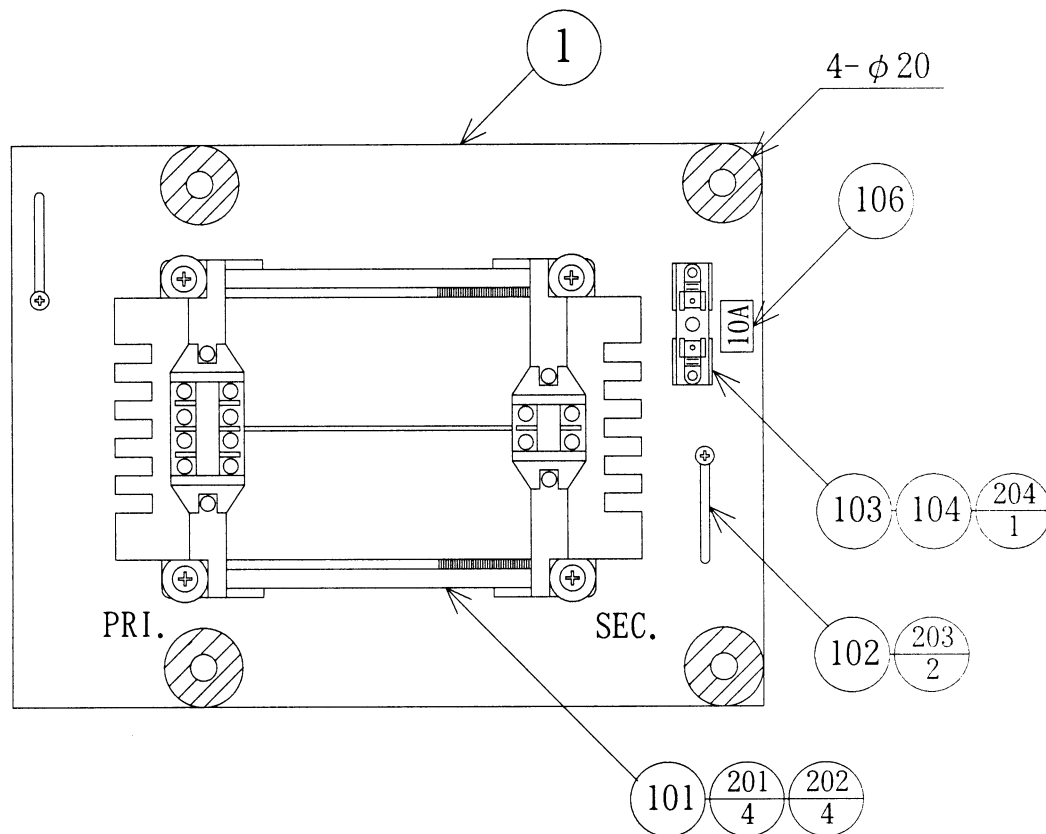

Note: Make sure that there is no parts, wiring, etc. in the slash mark portions.

When assembling, change PRIMARY side pin assignments
if necessary depending on destinations.

ITEM NO.	PART NO.	DESCRIPTION
1	JEY-4201	WOODEN BASE TRANS EXP
101	560-5384	XFMR 100-120V 100V 10A WB
102	280-0419	HARNES LUG
103	514-5095-10000	FUSE S.B 10000MA 250V HBC
104	514-5093	FUSE HLDR F-64AB COVER
105	310-5029-F20	SUMITUBE F F 20MM
106	421-6595-08	STICKER 10A
201	000-P00516-W	M SCR PH W/FS M5 X 16
202	068-552016	FLT WSHR 5.5-20 X 1.6
203	011-T03512	TAP SCR TH 3.5 X 12
204	011-P00316	TAP SCR #1 PH 3 X 16
301	JEY-60080	WIRE HARN XFMR IN
302	JEY-60081	WIRE HARN XFMR 100V OUT

29 ASSY TRANS EXP 200V LINES (JEY-4210)

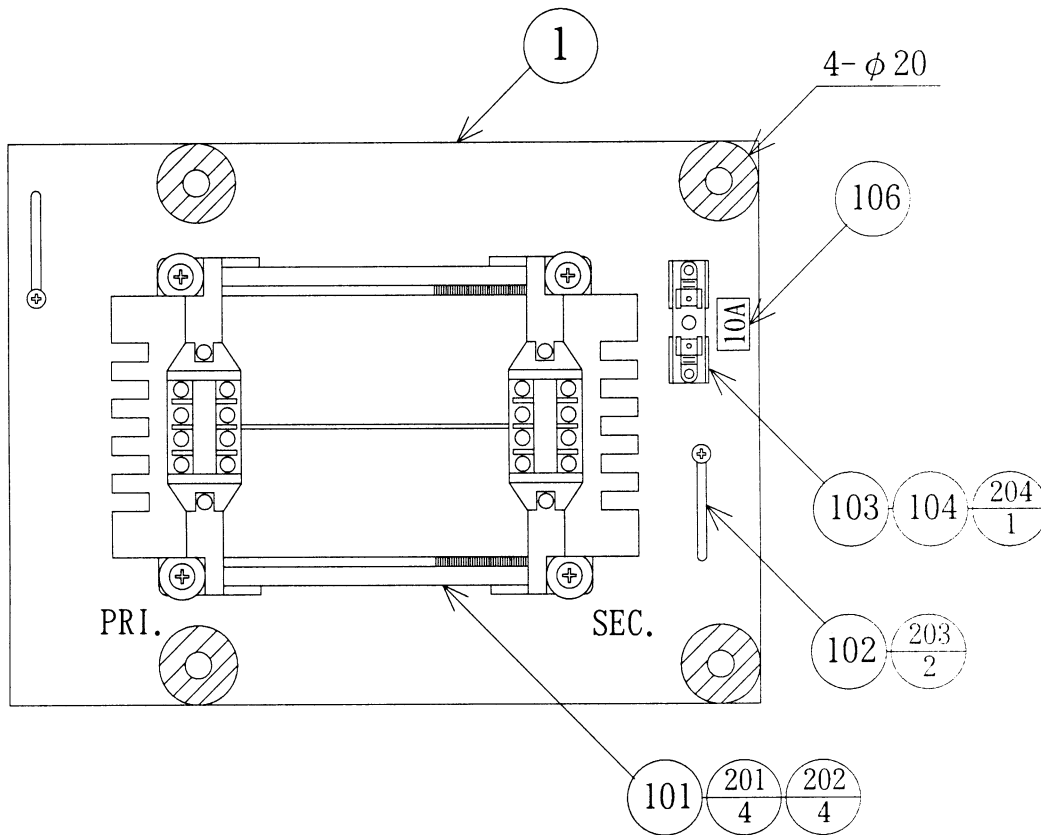

Note: Make sure that there is no parts, wiring, etc. in the slash mark portions.
When assembling, change PRIMARY side pin assignments
if necessary depending on destinations.

ITEM NO.	PART NO.	DESCRIPTION
1	JEY-4201	WOODEN BASE TRANS EXP
101	560-5377	PWR XFMR 200-240V 100V 10A CE
102	280-0419	HARNES LUG
103	514-5095-10000	FUSE S.B 10000MA 250V HBC
104	514-5093	FUSE HLDR F-64AB COVER
105	310-5029-F20	SUMITUBE F F 20MM
106	421-6595-08	STICKER 10A
201	000-P00516-W	M SCR PH W/FS M5 X 16
202	068-552016	FLT WSHR 5.5-20 X 1.6
203	011-T03512	TAP SCR TH 3.5 X 12
204	011-P00316	TAP SCR #1 PH 3 X 16
301	JEY-60080	WIRE HARN XFMR IN
302	JEY-60081	WIRE HARN XFMR 100V OUT

19. WIRE COLOR CODE TABLE

THE WIRE COLOR CODE is as follow:

- A PINK
- B SKY BLUE
- C BROWN
- D PURPLE
- E LIGHT GREEN

Wires other than those of any of the above 5 single colors will be displayed by 2 alphanumeric characters.

- 1 RED
- 2 BLUE
- 3 YELLOW
- 4 GREEN
- 5 WHITE
- 7 ORANGE
- 8 BLACK
- 9 GRAY

If the right-hand side numeral of the code is 0, then the wire will be of a single color shown by the left-hand side numeral (see the above).

Note 1: If the right-hand side alphanumeric is not 0, that particular wire has a spiral color code. The left-hand side character shows the base color and the right-hand side one, the spiral color.

<Example> 51 WHITE / RED

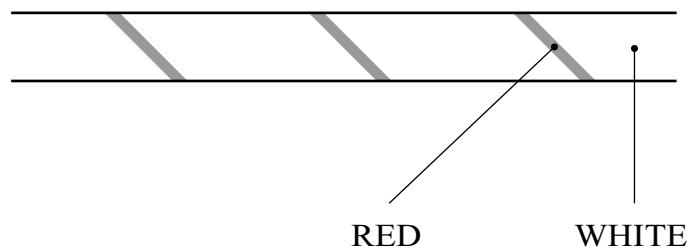

Note 2: The character following the wire color code indicates the size of the wire.

- U: AWG16
- K: AWG18
- L: AWG20
- None: AWG22

VISIT OUR WEBSITE!

The screenshot shows a Netscape browser window displaying the SegaService.com website. The browser's address bar shows the URL <http://www.seuservice.com/>. The website's navigation menu on the left includes links for "what's new", "manuals", "bulletins", "assy pages", "staff", "Darl's Office", "corporate info", "technical service", "warranty Policy", "plug-ins", "home page", "non-framed page", and "seu mailing list". The main content area features a large "SEGA SERVICE" logo and a list of search criteria: "parts", "boards", "monitors", and "distributors". Below the logo, there is a list of services: "Darl's Office", "What's New", "Game Manuals", and "Bulletins". A statistics section reports that 5661 people have accessed the page since June 9th. Contact information for Darl Davidson and Dave Cantrelle is provided, along with the copyright notice for Sega Enterprise Inc., USA. The footer includes a logo for "WebSTAR 3" and mentions "Mac OS" and "Webula".

SegaService.com

Address: <http://www.seuservice.com/>

Search criteria: [parts](#) • [boards](#) • [monitors](#) • [distributors](#)

SEGA SERVICE

- Darl's Office
- What's New
- Game Manuals
- Bulletins

[\[what's new\]](#)[\[manuals\]](#)[\[bulletins\]](#)[\[staff\]](#)[\[Darl's office\]](#)
[\[technical service\]](#)[\[customer service\]](#)[\[corporate info\]](#)[\[plugins\]](#)[\[Non-framed page\]](#)

A total of **5661** people have accessed this page since June 9th.

If you have any questions or comments about this Home Page please E-Mail to:

darl.davidson@seu.sega.com OR dave.cantrelle@seu.sega.com

© Sega Enterprise Inc., USA. All rights reserved.

THIS WEB SITE POWERED BY
WebSTAR 3 Mac OS Webula

You will need the following items to view this page in its entirety.

Internet zone



SEGA ENTERPRISES, INC. (USA)

45133 Industrial Drive
Fremont, CA 94538
(415) 701-6580 phone
(415) 701-6594 fax