

SERVICE MANUAL

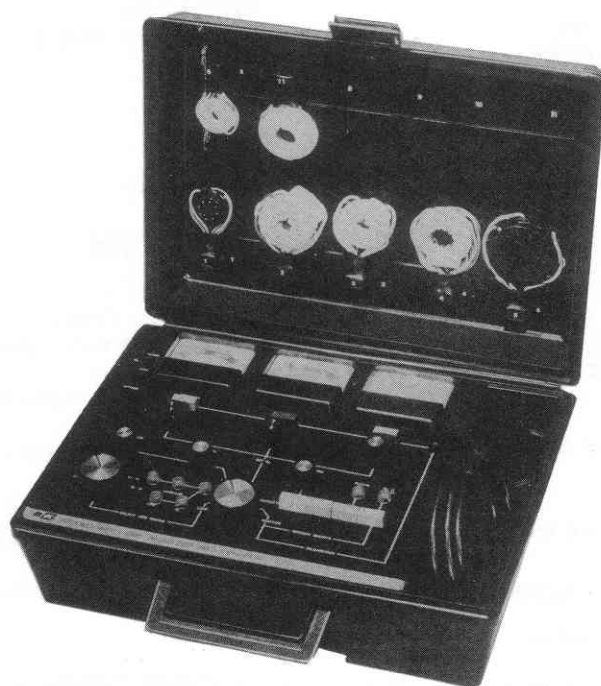

Model 467

# CATHODE RAY TUBE RESTORER/ANALYZER



**BK PRECISION**<sup>®</sup>

Maxtec International Corp. 6470 West Cortland Street Chicago, Illinois 60635

## DESCRIPTION

The Model 467 CRT Restorer/Analyzer has been designed to evaluate all Black and White and Color television picture tubes with a high degree of accuracy by using just one simple test.

This tester utilizes solid-state digital multiplexing circuits which will test the three guns in rapid fire sequence for emission, tracking, leakage, focus, and

life tests. The tester also provides improved rejuvenation circuits which can remove shorts, clean and balance the guns, and restore the emission capabilities of the cathode for each gun independently.

Adapters are provided to directly test all common TV picture tubes. Refer to the Set-Up Chart for the correct adapter number and test voltage to use.

## SPECIFICATIONS

Tests Performed	Emission Leakage Tracking (Color Tubes) Life Focus Continuity	Test Voltages Heater G1 Bias G2 Supply	0-7 @ 2.0 Amps 7-14 @ 600 Milliamps Neg. (-) 30 to Neg. (-) 100 Volts DC Normal, 0-350 Volts DC High, 180-530 Volts DC
Restore Functions	Short Removal Gun Cleaning and Balancing Cathode Rejuvenation	Power Requirements	117 Volts AC, 60 Hz, 40 Watts
Meters	Three, 2-1/2", D'Arsonval Movement	Fuses (Internal) Heater Supply High Voltage Supply	3/10 Amp, 3AG Slo-Blo 3/8 Amp, 3AG Slo-Blo
Meter Indications		Size	13-1/2" x 10" x 5-3/4"
Emission	0-2 ma.	Weight	10 lbs
Restoring Current	0-2 Scale		
Heater Voltage	0-15 Volts		
G1 Bias Voltage	30-100 Volts		
Power Line Voltage	100-130 Volts		

## DISASSEMBLY INSTRUCTIONS

### To Remove from Case

1. Remove four screws holding rubber feet from bottom of case.
2. Remove one screw and washer from front of case (below lid catch).
3. Lift chassis upward and remove from case.

### To Remove Printed Circuit Board Assembly

1. Remove all knobs from front panel.
2. Remove retaining nuts and washers from the Red G2 and Blue G2 controls, and the Function switch.
3. Remove one screw from right front side of front panel cover.

4. Partially remove the front panel cover and disconnect wires from each meter.
5. Remove neon bulbs N1 thru N8 from lens caps.
6. Remove front panel cover.
7. Remove two screws holding line cord and output cable assembly bracket to chassis.
8. Remove four screws holding printed board to chassis.
9. Partially remove printed board from chassis far enough to remove cable connectors A and B from printed board.
10. Remove printed board assembly from chassis.

## REASSEMBLY

1. Place front panel cover in front of chassis in its proper position.
2. Position printed board assembly against bottom of chassis and connect meter leads to their respective meter. Make sure positive (+) lead and negative (-) are connected properly to the meter.

Refer to schematic (Fig. 3) and printed board layout (Fig. 2) to determine correct lead identification.

3. Position front panel cover onto chassis and replace retaining nuts and washers on Red G2 and Blue G2 controls and tighten.

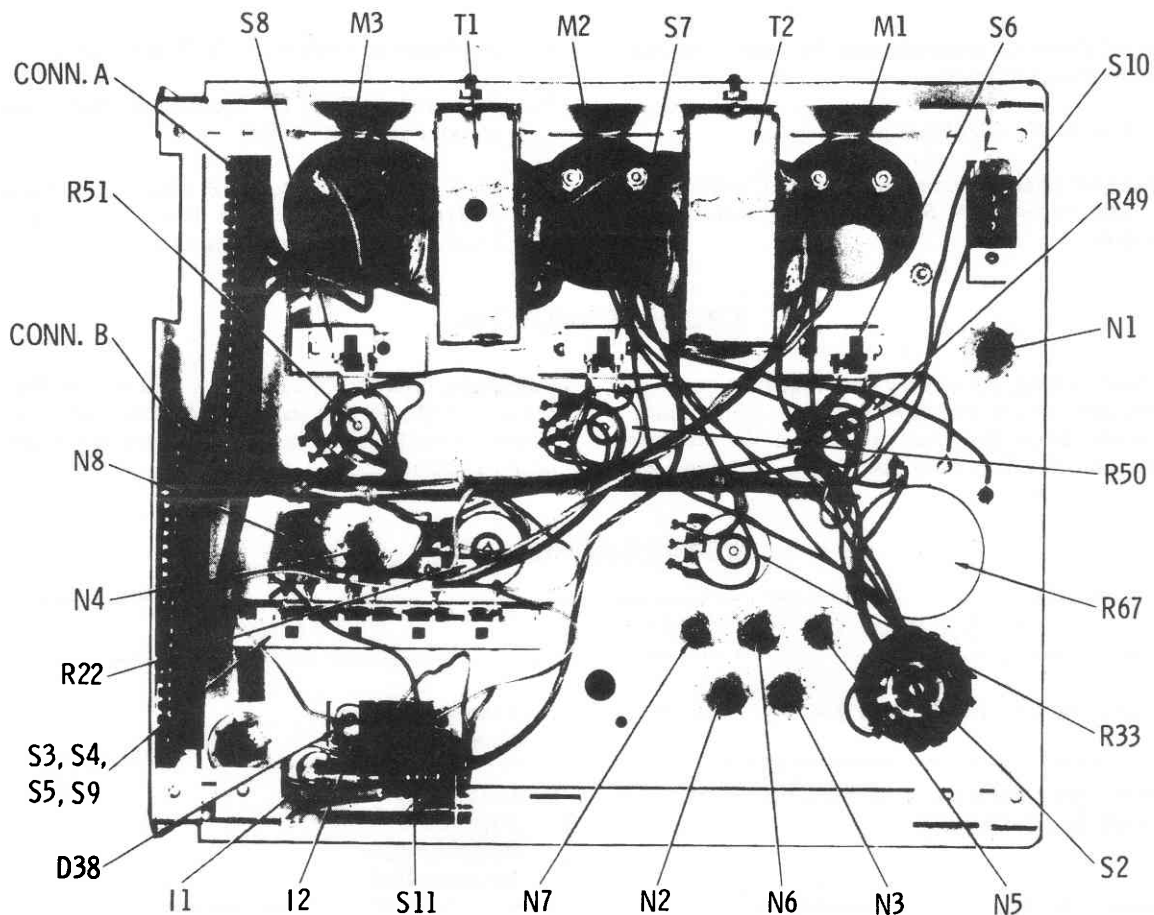

Fig. 1. Rear View of Front Panel – Parts Location.

4. Replace screw on front right side of chassis.
5. Insert neon bulbs N1 thru N8 into their proper lens cap. Refer to the schematic (Fig. 3) and printed board layout (Fig. 2) to determine correct placement of bulbs.
6. Replace connectors A and B onto printed board.
7. Place printed board onto chassis and replace retaining nut and washer on Function switch and tighten.
8. Replace two screws holding line cord and output cable to chassis.
9. Replace four screws holding printed board to chassis.
10. Replace all knobs on front panel controls.
11. Lower chassis into case and replace screw and washer on front of case and four screws and rubber feet on bottom of case.

## CALIBRATION ADJUSTMENTS

### Heater Voltage

1. Connect Adapter No. 3 to output cable.
2. Connect an AC voltmeter to pins 1 and 14 of adapter.
3. Set voltmeter to the 10-volt range.
4. Connect AC line cord of tester into 117 VAC outlet and set Function control to the SET-UP position.
5. Set HTR Range switch to the 4-7 volt position.
6. Adjust HTR control to read exactly 6.3 volts on external AC voltmeter.
7. Adjust HTR Cal control (R16) on printed board (see Fig. 2 for location) so that HTR voltmeter on tester (Red/B&W) indicates exactly 6.3 volts.

### Tracking Range

1. Connect Adapter No. 3 to output cable.
2. Connect a 100K, 1/2 Watt resistor between pins 2 and 13 of adapter.

3. Turn all three G2 controls and Tracking control fully counterclockwise.
4. Set G2 switch to NORMAL position.
5. Connect AC cord of tester into 117 VAC outlet and set Function switch to SET-UP position until unit warms up.
6. Set Function switch to TEST position.
7. Adjust Red/B&W G2 control so that Red/B&W meter reads full scale.
8. Push tracking button and adjust Min Pulse Cal control (R23) on printed board (see Fig. 2 for location) for minimum reading.

## TROUBLESHOOTING

All troubleshooting procedures such as voltage measurements, waveform analysis, and adjustments can be made from the bottom side of the printed circuit board. See Fig. 2 for location of voltage and

waveform test points and the schematic in Fig. 3 for correct voltages and waveforms. Disassembly of the printed board will only be necessary if a component needs replacing.

## TROUBLESHOOTING CHART

Symptom	Check
Set inoperative. Power light does not come on.	<ol style="list-style-type: none"> <li>1. Fuse F1.</li> <li>2. Function switch S1.</li> </ol>
Power light comes on. Blue G2 meter does not indicate line voltage.	<ol style="list-style-type: none"> <li>1. Meter M3.</li> <li>2. Function switch S1.</li> <li>3. Rectifier D16.</li> <li>4. Resistor R20.</li> </ol>
Heater circuit inoperative on all positions. HTR Set control does not function.	<ol style="list-style-type: none"> <li>1. Fuse F2.</li> <li>2. Function switch S1.</li> <li>3. HTR Range switch S2.</li> <li>4. Secondary voltages of transformer T2.</li> <li>5. HTR Cal control R16.</li> <li>6. Rejuvenate switches S6B, S7B, and S8B.</li> <li>7. Cable connector A.</li> </ol>
CRT heater lights. Meter does not indicate voltage.	<ol style="list-style-type: none"> <li>1. Meter M1.</li> <li>2. HTR Cal control R16.</li> <li>3. Diode D30.</li> <li>4. Resistors R17, R18, and R69.</li> </ol>
No G1 control voltage.	<ol style="list-style-type: none"> <li>1. Meter M2.</li> <li>2. G1 control R33.</li> <li>3. Rectifier D18.</li> <li>4. Transformer T1.</li> <li>5. Capacitor C20.</li> <li>6. Resistors R32 and R35.</li> </ol>
One G2 control fails to adjust properly.	<ol style="list-style-type: none"> <li>1. Collectors of Q2, Q3, and Q4 with scope for typical square wave. A straight line indicates a bad transistor.</li> <li>2. G2 controls R49, R50, and R51.</li> <li>3. Transistors Q5, Q6, Q7.</li> <li>4. Multiplex generator voltages and waveforms.</li> <li>5. IC1A, IC1B, IC2C, and IC2D.</li> </ol>
All G2 controls fail to adjust properly.	<ol style="list-style-type: none"> <li>1. 12BH7A tube V1.</li> <li>2. Transistor Q1.</li> <li>3. Rectifiers D1 thru D4.</li> <li>4. Transformer T1.</li> <li>5. Capacitors C11 and C12.</li> <li>6. Resistors R41 and R43.</li> <li>7. Multiplex generator waveforms.</li> <li>8. IC1A, IC1B, IC2C, and IC2D.</li> </ol>

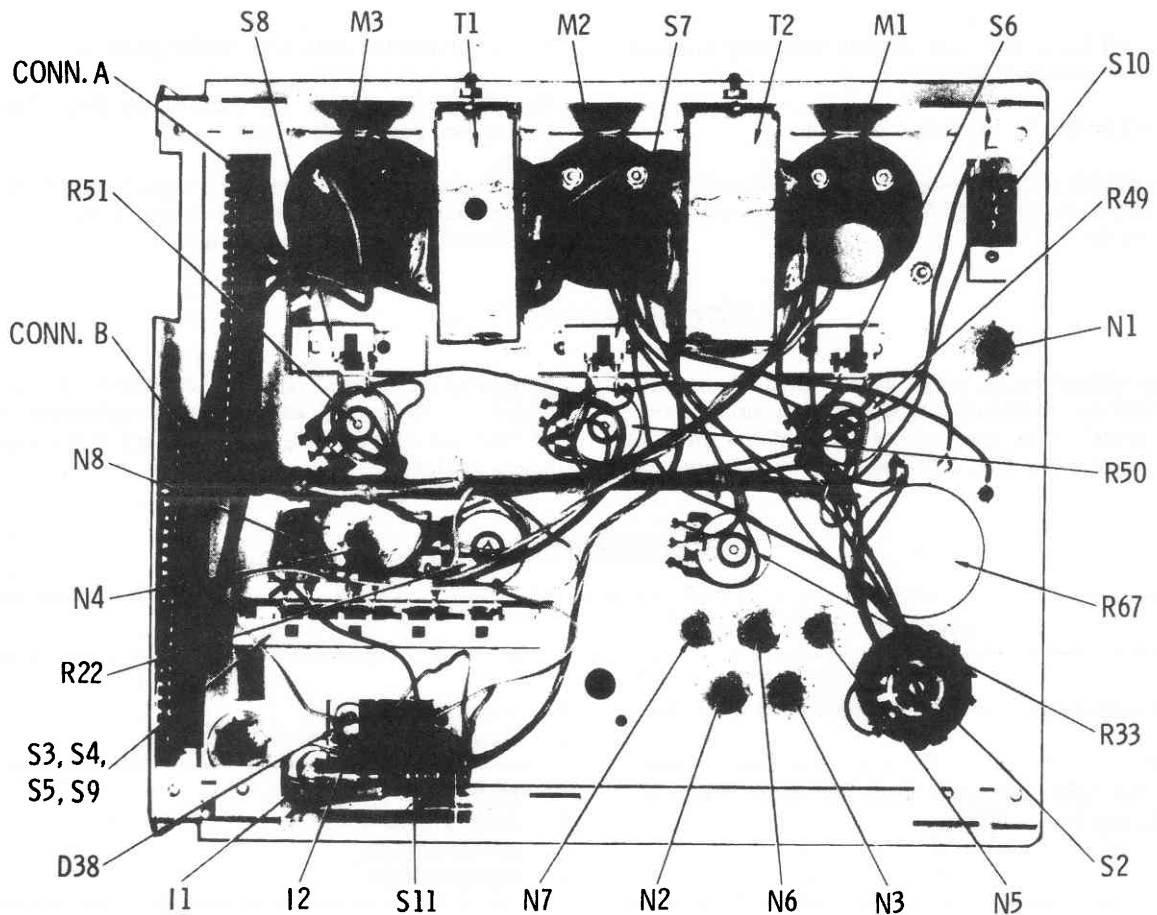

Fig. 1. Rear View of Front Panel — Parts Location.

4. Replace screw on front right side of chassis.
5. Insert neon bulbs N1 thru N8 into their proper lens cap. Refer to the schematic (Fig. 3) and printed board layout (Fig. 2) to determine correct placement of bulbs.
6. Replace connectors A and B onto printed board.
7. Place printed board onto chassis and replace retaining nut and washer on Function switch and tighten.
8. Replace two screws holding line cord and output cable to chassis.
9. Replace four screws holding printed board to chassis.
10. Replace all knobs on front panel controls.
11. Lower chassis into case and replace screw and washer on front of case and four screws and rubber feet on bottom of case.

## CALIBRATION ADJUSTMENTS

### Heater Voltage

1. Connect Adapter No. 3 to output cable.
2. Connect an AC voltmeter to pins 1 and 14 of adapter.
3. Set voltmeter to the 10-volt range.
4. Connect AC line cord of tester into 117 VAC outlet and set Function control to the SET-UP position.
5. Set HTR Range switch to the 4-7 volt position.
6. Adjust HTR control to read exactly 6.3 volts on external AC voltmeter.
7. Adjust HTR Cal control (R16) on printed board (see Fig. 2 for location) so that HTR voltmeter on tester (Red/B&W) indicates exactly 6.3 volts.

### Tracking Range

1. Connect Adapter No. 3 to output cable.
2. Connect a 100K, 1/2 Watt resistor between pins 2 and 13 of adapter.

3. Turn all three G2 controls and Tracking control fully counterclockwise.
4. Set G2 switch to NORMAL position.
5. Connect AC cord of tester into 117 VAC outlet and set Function switch to SET-UP position until unit warms up.
6. Set Function switch to TEST position.
7. Adjust Red/B&W G2 control so that Red/B&W meter reads full scale.
8. Push tracking button and adjust Min Pulse Cal control (R23) on printed board (see Fig. 2 for location) for minimum reading.

## TROUBLESHOOTING

All troubleshooting procedures such as voltage measurements, waveform analysis, and adjustments can be made from the bottom side of the printed circuit board. See Fig. 2 for location of voltage and

waveform test points and the schematic in Fig. 3 for correct voltages and waveforms. Disassembly of the printed board will only be necessary if a component needs replacing.

## TROUBLESHOOTING CHART

Symptom	Check
Set inoperative. Power light does not come on.	<ol style="list-style-type: none"> <li>1. Fuse F1.</li> <li>2. Function switch S1.</li> </ol>
Power light comes on. Blue G2 meter does not indicate line voltage.	<ol style="list-style-type: none"> <li>1. Meter M3.</li> <li>2. Function switch S1.</li> <li>3. Rectifier D16.</li> <li>4. Resistor R20.</li> </ol>
Heater circuit inoperative on all positions. HTR Set control does not function.	<ol style="list-style-type: none"> <li>1. Fuse F2.</li> <li>2. Function switch S1.</li> <li>3. HTR Range switch S2.</li> <li>4. Secondary voltages of transformer T2.</li> <li>5. HTR Cal control R16.</li> <li>6. Rejuvenate switches S6B, S7B, and S8B.</li> <li>7. Cable connector A.</li> </ol>
CRT heater lights. Meter does not indicate voltage.	<ol style="list-style-type: none"> <li>1. Meter M1.</li> <li>2. HTR Cal control R16.</li> <li>3. Diode D30.</li> <li>4. Resistors R17, R18, and R69.</li> </ol>
No G1 control voltage.	<ol style="list-style-type: none"> <li>1. Meter M2.</li> <li>2. G1 control R33.</li> <li>3. Rectifier D18.</li> <li>4. Transformer T1.</li> <li>5. Capacitor C20.</li> <li>6. Resistors R32 and R35.</li> </ol>
One G2 control fails to adjust properly.	<ol style="list-style-type: none"> <li>1. Collectors of Q2, Q3, and Q4 with scope for typical square wave. A straight line indicates a bad transistor.</li> <li>2. G2 controls R49, R50, and R51.</li> <li>3. Transistors Q5, Q6, Q7.</li> <li>4. Multiplex generator voltages and waveforms.</li> <li>5. IC1A, IC1B, IC2C, and IC2D.</li> </ol>
All G2 controls fail to adjust properly.	<ol style="list-style-type: none"> <li>1. 12BH7A tube V1.</li> <li>2. Transistor Q1.</li> <li>3. Rectifiers D1 thru D4.</li> <li>4. Transformer T1.</li> <li>5. Capacitors C11 and C12.</li> <li>6. Resistors R41 and R43.</li> <li>7. Multiplex generator waveforms.</li> <li>8. IC1A, IC1B, IC2C, and IC2D.</li> </ol>

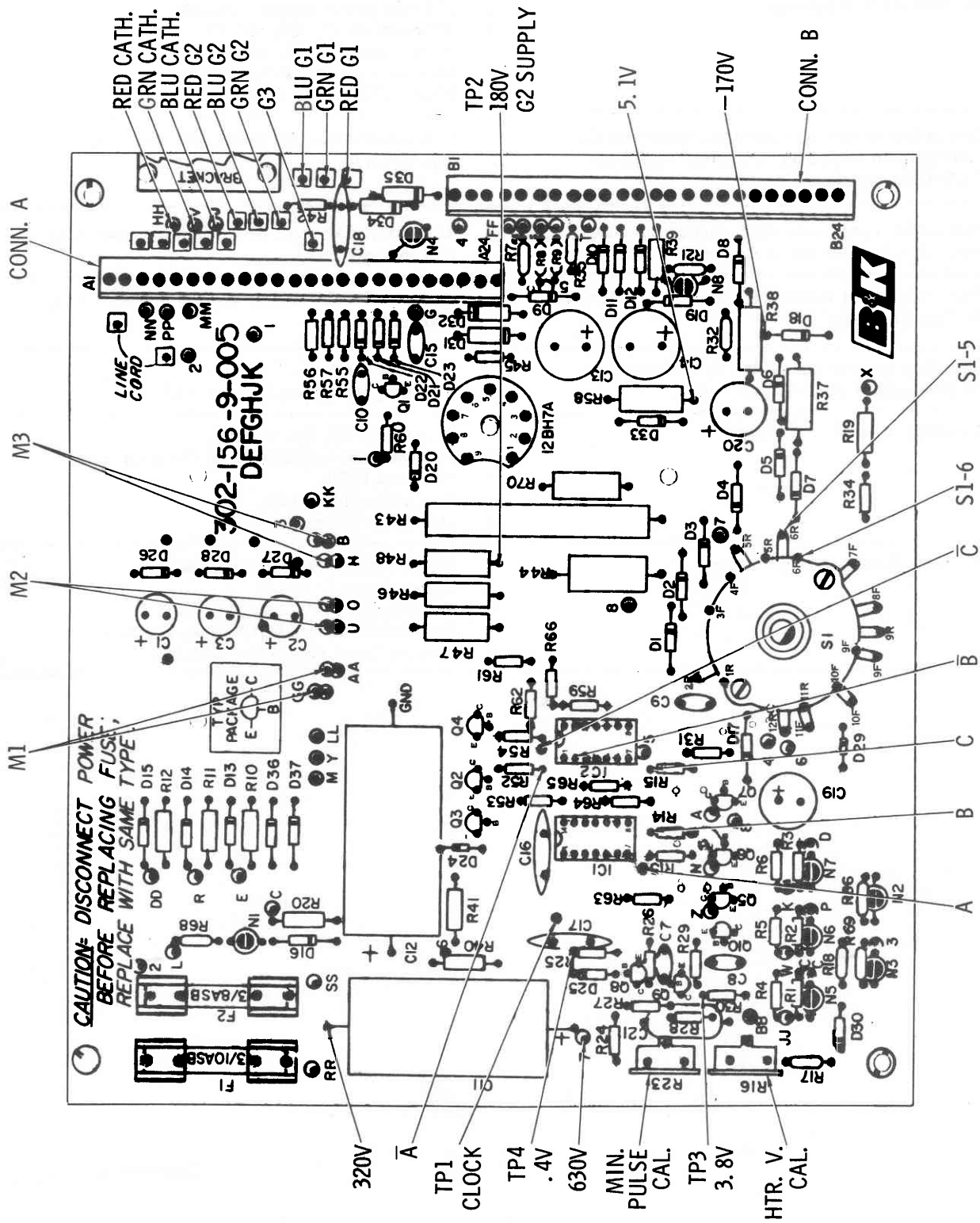

Fig. 2. Printed Circuit Board Layout - Component Side.

## TROUBLESHOOTING CHART(cont'd.)

Symptom	Check
No indication of leakage.	<ol style="list-style-type: none"> <li>1. 170 volt power supply voltages.</li> <li>2. Transistors Q5, Q6, and Q7.</li> <li>3. Neon lamps N5, N6, and N7.</li> <li>4. Multiplex generator waveforms.</li> <li>5. IC1A, IC1B, IC2C, IC2D.</li> </ol>
One meter moves upscale when other two G2 controls are turned up. Function switch in CUT-OFF position.	<ol style="list-style-type: none"> <li>1. Transistors Q5, Q6, or Q7 (the one switching that meter).</li> </ol>
One meter reads noticeably higher than other two. Function switch in CUT-OFF position.	<ol style="list-style-type: none"> <li>1. Transistors Q5, Q6, or Q7 (the one switching that meter).</li> </ol>
One meter falls noticeably lower than other two in Tracking test.	<ol style="list-style-type: none"> <li>1. Transistors Q5, Q6, or Q7 (the one switching that meter).</li> </ol>
Tracking control works, but in reverse direction and/or not with full range.	<ol style="list-style-type: none"> <li>1. Transistor Q10.</li> <li>2. Tracking Range adjustment (R23).</li> </ol>
Tracking circuit inoperative.	<ol style="list-style-type: none"> <li>1. Transistor Q8, Q9, or Q10.</li> <li>2. Voltages and components in clock circuit.</li> <li>3. IC2A and IC2B.</li> <li>4. Tracking control R22.</li> <li>5. Min Pulse Cal control R23.</li> </ol>
Restore Functions inoperative.	<ol style="list-style-type: none"> <li>1. 270 volt power supply voltages</li> <li>2. Ballast tubes I1 and I2.</li> <li>3. Rectifiers D5, D6, and D7.</li> <li>4. Rejuvenate switches S6A, S7A, and S8A.</li> <li>5. Remove Short switch S4A and S4B.</li> </ol>



# PARTS LIST

**NOTE:**

Standard value resistors and capacitors are not listed. Minimum charge \$5.00 per invoice. Orders will be shipped C.O.D. unless previous open account arrangements have been made or

remittance accompanies order. Advance remittance must cover postage or express charges. Specify serial number when ordering replacement parts.

Ref. No.	Part No.	Description
----------	----------	-------------

**TRANSISTORS**

Q1 thru Q7	176-033-9-001	2N5550, NPN, Silicon
Q8, Q9, Q10	176-052-9-001	PN3643, NPN, Silicon

**IC CIRCUITS**

IC1	307-010-9-001	7473, Dual J-K Flip-Flop
IC2	307-015-9-001	7400, Quad Two Input NAND Gate

**DIODES AND RECTIFIERS**

D1 thru D19	151-018-9-001	Rectifier, 600 PIV, 1 Amp
D20 thru D29	151-038-9-001	1N4148, Diode, Silicon
D30	150-008-9-001	1N67A, Diode Germanium
D31	152-056-9-001	Zener, 56V, $\pm 10\%$ , 1 Watt
D32	152-014-9-001	Zener, 24V, $\pm 5\%$ , 1 Watt
D33	152-030-9-001	Zener, 5.1V, $\pm 5\%$ , 1 Watt
D34	152-058-9-001	Zener, 51V, $\pm 10\%$ , 1 Watt
D35	152-058-9-001	Zener, 91V, $\pm 10\%$ , 1 Watt
D36	152-056-9-001	Zener, 56V, $\pm 10\%$ , 1 Watt
D37	152-056-9-001	Zener, 56V, $\pm 10\%$ , 1 Watt

**CAPACITORS**

C1	022-109-9-001	220 mfd, 100V, Electrolytic
C2	022-109-9-001	220 mfd, 100V, Electrolytic
C3	022-109-9-001	220 mfd, 100V, Electrolytic
C11	021-056-9-001	50 mfd, 450V, Electrolytic
C12	021-056-9-001	50 mfd, 450V, Electrolytic
C13	022-084-9-001	1000 mfd, 16V, Electrolytic
C14	022-084-9-001	1000 mfd, 16V, Electrolytic
C19	021-040-9-001	10 mfd, 250V, Electrolytic
C20	021-040-9-001	10 mfd, 250V, Electrolytic

**CONTROLS AND RESISTORS**

R7	002-104-8-249	2.4 $\Omega$ , $\pm 5\%$ , 1/4 Watt, Carbon
R8	002-104-8-249	2.4 $\Omega$ , $\pm 5\%$ , 1/4 Watt, Carbon
R9	002-104-8-249	2.4 $\Omega$ , $\pm 5\%$ , 1/4 Watt, Carbon
R10	002-104-8-249	2.4 $\Omega$ , $\pm 1\%$ , 1/2 Watt, Carbon
R11	002-017-9-001	316 $\Omega$ , $\pm 1\%$ , 1/2 Watt, Carbon
R12	002-017-9-001	316 $\Omega$ , $\pm 1\%$ , 1/2 Watt, Carbon
R16	008-058-9-001	10K, $\pm 20\%$ , Trimpot, HTR Cal.
R19	002-032-9-001	499K, $\pm 10\%$ , 1/2 Watt, Carbon Film
R20	002-031-9-001	340K, $\pm 10\%$ , 1/2 Watt, Carbon Film
R22	008-135-9-001	50K, $\pm 10\%$ , 1/2 Watt, Tracking Control

Ref. No.	Part No.	Description
----------	----------	-------------

**CONTROLS AND RESISTORS(Cont'd.)**

R23	008-071-9-001	250K, $\pm 30\%$ , Trimpot, Min. Pulse Cal.
R33	008-135-9-001	50K, $\pm 10\%$ , 1/2 Watt, Set G1 Control
R39	006-102-9-479	4.7 $\Omega$ , $\pm 10\%$ , 1/2 Watt, Wirewound
R43	003-010-6-303	30K, 10 Watt, Wirewound Glass
R49	008-135-9-001	50K, $\pm 10\%$ , 1/2 Watt, Red G2 Control
R50	008-135-9-001	50K, $\pm 10\%$ , 1/2 Watt, Green G2 Control
R51	008-135-9-001	50K, $\pm 10\%$ , 1/2 Watt, Blue G2 Control
R67	009-029-9-001	3 $\Omega$ , $\pm 10\%$ , 12 Watt, Wirewound, HTR Adj. Control

**SWITCHES**

S1	083-165-9-001	5-Position Rotary, Function
S2	083-091-9-001	6-Position Rotary, Htr Range
S3,4, 5,9	088-020-9-001	4-Station Pushbutton Ass'y., Tracking, Life, Focus, Remove Shorts
S6	088-021-9-001	DPDT Momentary, Red-B&W Rej.
S7	088-021-9-001	DPDT Momentary, Green Rej.
S8	088-021-9-001	DPDT Momentary, Blue Rej.
S10	084-001-9-001	SPDT Slide, G2 High-Normal
S11	084-001-9-003	DPDT Slide, Rejuvenate, Clean-Balance

**MISCELLANEOUS**

F1	190-004-9-001	Fuse, 3/10A, 250V, 3AG Slo-Blo
F2	190-251-3-308	Fuse, 3/8A, 250V, 3AG Slo-Blo
I1	400-034-9-001	Bulb, 230V, 10 Watt
I2	400-034-9-001	Bulb, 230V, 10 Watt
N1 thru N8	401-016-9-001	Bulb, Neon, NE-2
T1	065-098-9-001	Transformer, Power
T2	062-004-9-001	Transformer, Filament
M1	320-059-9-001	Meter, Heater Volts
M2	320-060-9-001	Meter, G1 Volts
M3	320-058-9-001	Meter, Line Volts
V1	236-120-2-087	12BH7A, Tube
	420-001-9-009	Line Cord
	523-107-9-001	Case Assembly
	751-005-9-008	Knob, Function
	751-112-9-001	Knob, Small (6 Used)
	751-115-9-001	Knob, Heater Range
	384-016-9-006	Knob, Pushbutton
	750-003-9-001	Lens Cap, Red (2 Used)
	750-003-9-002	Lens Cap, Clear (7 Used)
	381-002-9-001	Rubber Foot
	752-007-9-001	Socket, Lamp
	758-021-9-001	Vinyl Divider Flap
	763-027-9-001	Hinge Wire, Flap
	523-103-9-001	Adapter Storage Assembly
		Output Cable Assembly

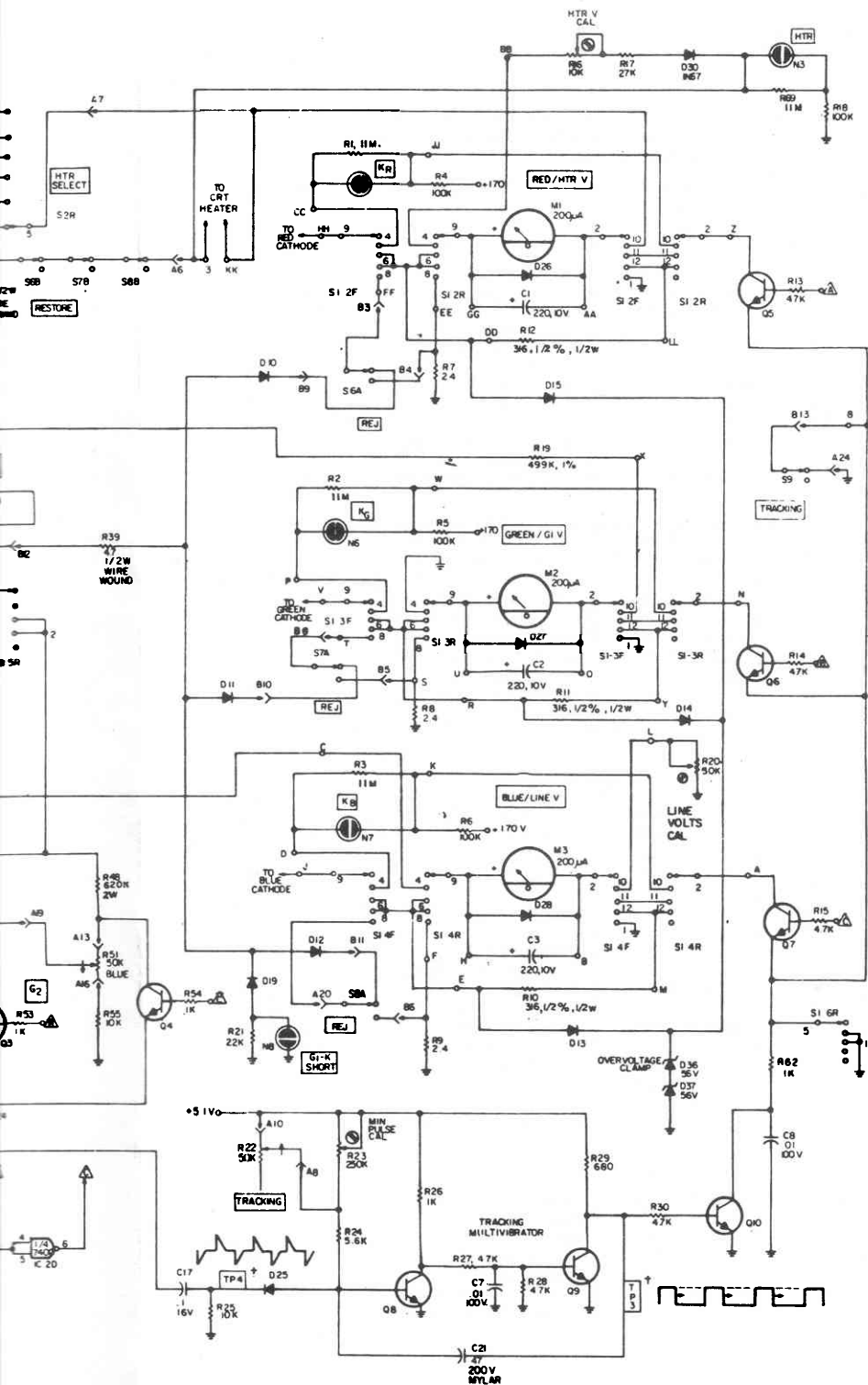

**CAUTION: THIS UNIT CONTAINS HIGH VOLTAGE SUPPLIES, BE CAUTIOUS WHEN SERVICING.**

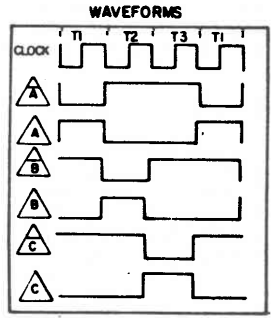

**OUTPUT CABLE**

FUNCTION	WIRE COLOR	PIN NO.
HTR	BLK	1
HTR	GRN	2
G1 RED	GRY	3
G1 GRN	TAN	4
G1 BLU	PUR	5
K RED	RED	6
K GRN	GRN	7
K BLU	BLU	8
G2 RED	ORG	9
G2 GRN	YEL	10
G2 BLU	PINK	11
G3 / G4	WHT	12

**SWITCH LEGEND (S1)**

POSITION	FUNCTION
1	POWER OFF
2	SET UP
3	SET CUTOFF
4	TEST
5	RESTORE

**NOTE:**

- ALL RESISTORS ARE 5%, 1/4W, UNLESS OTHERWISE SPECIFIED.
- ALL 1% RESISTORS ARE 1/2W, UNLESS OTHERWISE SPECIFIED.
- ALL CAPACITORS SHOWN IN MICROFARADS.
- ARROWS ON POT WIPERS INDICATE CLOCKWISE ROTATION.

5 THIS SCHEMATIC SUBJECT TO CHANGE WITHOUT NOTICE.  
 Δ AND ∇ INDICATE LOGIC SYMBOLS  
 ↓ CIRCUIT GND → CHASSIS  
 (↑ VARIES WITH CONTROL SETTINGS)

**CIRCUIT SYMBOL LEGEND**

LAST NUMBER USED	NOT USED
C22	4
D38	16
I2	
I C2	
M3	
N8	
Q10	
R72	
S11	
F2	
T2	

Fig. 3. Model 467 Schematic.

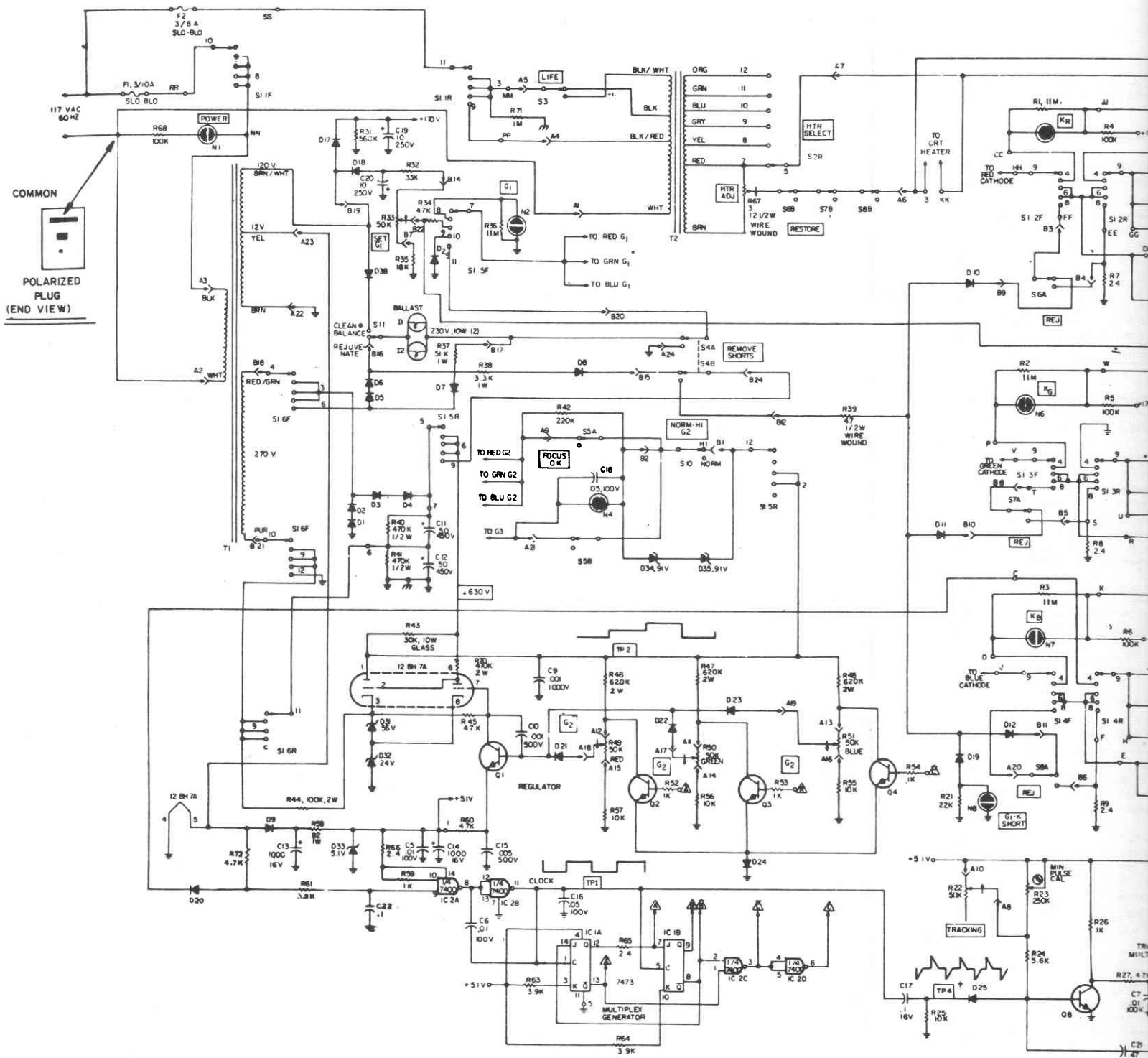

PICTORIAL VIEW OF SWITCH WAFERS

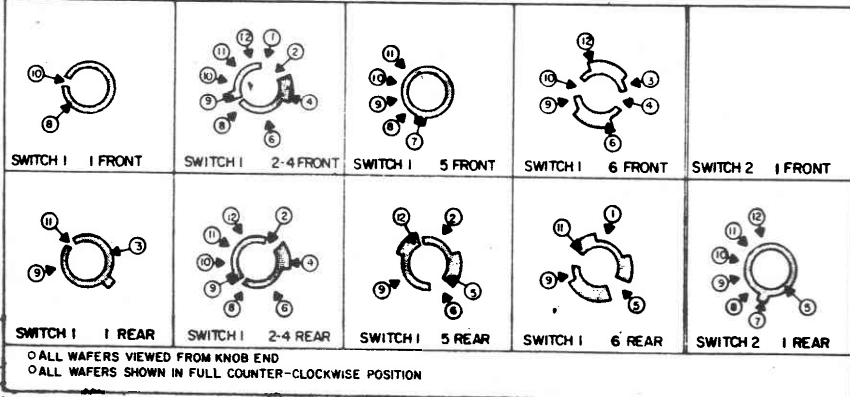

SWITCH LEGEND (SI)

POSITION	FUNCTION
1	POWER OFF
2	SET UP
3	SET CUTOFF
4	TEST
5	RESTORE

NOTE:

- 1 ALL RESISTOR
- 2 ALL 1% RES
- 3 ALL CAPACIT
- 4 ARROWS ON R
- 5 THIS SCHEM
- 6 AND 7
- 7 CIRCUIT ON
- 8 (↑ VARIES WITH COVER

Fig. 3. Model 467 Schematic.