



MOTOROLA

Service Manual

CAUTION

No work should be attempted on any exposed monitor chassis by anyone not familiar with servicing procedures and precautions.

A. GENERAL INFORMATION

This manual contains information on the M5000/M7000 monitor series and the +5 volt logic power supply. The M5000 uses a 19-inch CRT and the M7000 uses a 23-inch CRT. All CRTs are of the magnetic deflection type with integral implosion protection.

All monitor power supplies are capable of producing both +73 and +12 volts regulated from either 115-volt or 230-volt AC input to the transformer primary. All monitor variations described herein require a composite video input signal.

Note

This service manual refers to the Sky Raider Monitor only

Input and output connections for the monitors are made through a 12-pin connector plug located at the rear of the chassis. Inputs consist of composite video, audio, and 115/220 volt AC three-wire.

All monitors employ: four stages of video amplification, a two-stage sync separator, a two-stage vertical integrator, a four-stage horizontal sweep circuit, a three-stage vertical sweep circuit, a one-stage spot kill, a one stage blanking amplifier; and a regulated, full-wave bridge power supply.

Model Breakdown Chart

Model	Video Input	19" CRT	23" CRT
M5000-155	Composite	X	
M7000-155	Composite		X

SAFETY WARNING

CAUTION

No work should be attempted on an exposed monitor chassis by anyone not familiar with servicing procedures and precautions.

1. Safety procedures should be developed by habit so that technicians rushed with repair work automatically take precautions.
2. A good practice, when working on any unit, is to first ground the chassis and to use only one hand when testing circuitry. This will avoid the possibility of carelessly putting one hand on chassis or ground and the other on an electrical connection which could cause a severe electrical shock.
3. Extreme care should be used in *handling the picture tube* as rough handling may cause it to implode due to atmospheric pressure (14.7 lbs. per sq. in.). Do not nick or scratch glass or subject it to any undue pressure in removal or installation.

When handling, safety goggles and heavy gloves should be worn for protection. Discharge picture tube by shorting the anode connection to chassis ground (not cabinet or other mounting parts). When discharging, go from ground to anode or use a well-insulated piece of wire. When servicing or repairing the monitor, if the cathode ray tube is replaced by a type of tube other than that specified under the Motorola Part Number as original equipment in this Service Manual, then avoid prolonged exposure at close range to unshielded areas of the cathode ray tube. Possible danger of personal injury from unnecessary exposure to X-ray radiation may result.

4. An *isolation transformer* should always be used during the servicing of a unit whose chassis is connected to one side of the power line. Use a transformer of adequate power rating as this protects the serviceman from accidents resulting in personal injury from electrical shocks. It will also protect the chassis and its components from being



damaged by accidental shorts of the circuitry that may be inadvertently introduced during the service operation.

5. Always *replace protective devices*, such as fishpaper, isolation resistors and capacitors and shields after working on the unit.
6. *Before returning a serviced unit*, the service technician must thoroughly test the unit to be certain that it is completely safe to operate without danger of electrical shock. *Do not use a line isolation transformer when making this test.*

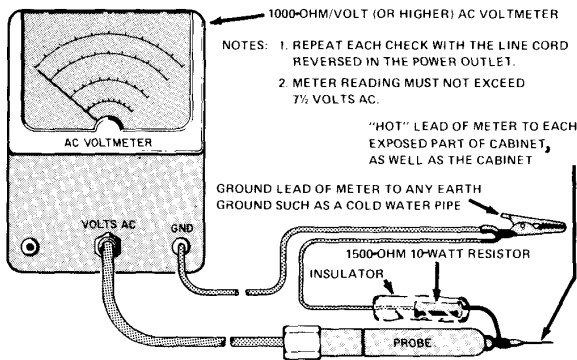

Voltmeter Hook-up for Safety Check

In addition to practicing the basic and fundamental electrical safety rules, the following test, which is related to the minimum safety requirements of the Underwriters Laboratories, should be performed by the service technician before any unit which has been serviced is installed in a game again.

A 1000-ohm-per-volt AC voltmeter is prepared by shunting it with a 1500-ohm, 10-watt resistor. The safety test is made by contacting one meter probe to any portion of the unit exposed to the operator such as the cabinet trim, hardware, controls, knobs, etc., while the other probe is held in contact with a good "earth" ground such as a cold water pipe.

The AC voltage indicated by the meter must not exceed 7½ volts. A reading exceeding 7½ volts indicates that a potentially dangerous leakage path exists between the exposed portion of the unit and earth ground. Such a unit represents a potentially serious shock hazard to the operator.

The above test should be repeated with the power plug reversed, when applicable.

Never reinstall a monitor which does not pass the safety test until the fault has been located and corrected.

Table 6-1 Motorola Monitor Electrical Specifications

	MODEL M5000-155	MODEL M7000-155
PICTURE TUBE	19" measured diagonally (48.2 cm); 184 sq. inch viewing area (1188 sq. cm); 114° deflection angle; integral implosion protection; P4 phosphor standard	23" measured diagonally (58.4 cm); 282 sq. inch viewing area (1820 sq. cm); 110° deflection angle; integral implosion protection; P4 phosphor standard
POWER INPUT	115/230 VAC, 110 Watts (nominal); 60 Hz provision for 230 VAC, 50 Hz	
FUSES	M5000-155, M7000-155—0.8A	
+73 VOLT SUPPLY	Electronically regulated over AC inputs from 103 VAC to 130 VAC, or 260 VAC to 260 VAC	
VIDEO INPUT	0.5 Volts to 2.5 Volts P/P maximum, composite for 50V at CRT	
RESOLUTION	500 lines at picture center	
LINEARITY	Within 3%, measured with standard EIA ball chart and dot pattern	

Table 6-1 Motorola Monitor Electrical Specifications

HIGH VOLTAGE	17KV (nominal)	
HORIZONTAL BLANKING INTERVAL	11 microseconds typical (includes retrace and delay)	
SCANNING FREQUENCY	Horizontal: 15,750 Hz±500 Hz; Vertical: 50/60 Hz	
ENVIRONMENT	Operating temperature: 10°C to 55°C (ambient) Storage Temperature: -40°C to +65°C Operating Altitude: 10,000 ft. maximum (3048 meters) Designed to comply with applicable DHEW rules on X-Radiation CSA certified for use in coin-operated amusements in a combustible enclosure UL listed under specification 1410 (electronic components)	
TYPICAL DIMENSIONS	14.11" H, 18.18" W, 14.83" D (35.8 x 46 x 37.6 cm)	16.72" H, 21.56" W, 16.18" D (42.4 x 54.7 x 41 cm)

Specifications subject to change without notice.

B. SERVICE NOTES

Circuit Tracing

Component reference numbers are printed on the top and bottom of the three circuit cards to facilitate circuit tracing. In addition, control names are also shown and referenced on the schematic diagram in this manual.

Transistor elements are identified as follows:
 E—Emitter, B—Base, C—Collector.

Component Removal

Removing components from an etched circuit card is facilitated by the fact that the circuitry (copper foil) appears on one side of the circuit card only and the component leads are inserted straight through the holes and are not bent or crimped.

It is recommended that a solder extracting gun be used to aid in component removal. An iron with a temperature-controlled heating element would be desirable since it would reduce the possibility of damaging the circuit card foil due to over-heating.

The nozzle of the solder extracting gun is inserted directly over the component lead and when sufficiently heated, the solder is drawn away, leaving the lead free from the copper foil. This method is particularly suitable in removing multi-terminal components.

CRT Replacement

Use extreme care in handling the CRT, as rough handling may cause it to implode due to high vacuum pressure. Do not nick or scratch glass or subject it to any undue pressure in removal or installation. Use goggles and heavy gloves for protection. In addition, be sure to disconnect the monitor from all external voltage sources.

1. Discharge CRT by shorting 2nd anode to ground; then remove the CRT socket, deflection yoke and 2nd anode lead.
2. Remove CRT from the front of the chassis by loosening and removing four screws, one in each corner of the CRT.

Adjustments

A non-metallic tool is recommended when performing the following adjustments.

Regulator Adjustment

NOTE

Misadjustment of the +73 volt regulator or the horizontal oscillator may result in damage to the horizontal output transistor or pulse-limiter diode. The following procedure is recommended to insure reliable operation.

1. Connect the monitor to an AC line supply; then adjust supply to 120 volts (240 volts in some applications).
 2. Apply test signal to proper input. Signal should be of same amplitude and sync rate as when monitor is in service.
 3. Adjust HOR. SET coil L1 until display is stable.
 4. Connect a DC digital voltmeter or equivalent precision voltmeter to the emitter of the regulator output transistor, Q17, or any +73 volt test point.
 5. Adjust the 73V ADJUST. control, R93, for an output of +73 volts. *Do not* rotate the control through its entire range; damage to the monitor may result.
 6. When adjustment is complete, the AC line supply can be varied between 103 and 130 volts AC to check for proper regulator operation. With the regulator operating properly, changes in display size should be negligible.
2. Rotate the vertical size control, R60, until the smallest display is obtained.
 3. Adjust the vertical linearity control, R64, until the top and bottom of the test pattern is equally spaced.
 4. Readjust R60 until the desired display height is obtained.
 5. Readjust R64, if necessary, as in Step 2 above.

Focus Adjustment

The best overall focus of the display is obtained by adjusting the focus control, R42, for best focus at a point which is near the center and approximately 1/3 down from the top of the display.

Monitor Servicing

The monitor circuit board may be installed in a service position to provide easier access to the circuit foil when servicing the monitor (see Figure 6-1).

C. THEORY OF OPERATION

Power Supply

The power supplies are transformer-operated, full-wave, regulated supplies which maintain constant output voltages for input line variations of 103 volts AC to 130 volts AC, or 206 volts AC to 260 volts AC. Regulation of the output voltages is accomplished by using positive feedback through the integrated circuit reference amplifier.

+73 Volt Supply (See Figures 6-3, 6-4)

When the +73 volt supply attempts to increase, the voltage at pin 3 of IC1 will increase, while the voltage at pin 2 remains constant due to D20. The increasing voltage at pin 3 will cause the output voltage of the reference amplifier (pin 6) to increase the forward bias of Q19. The collector voltage of Q19, forward bias of Q18, and the base current of Q17 will all decrease. The resultant proportional increase of Q17 collector-to-emitter voltage will cancel the attempted output voltage increase.

When the +73 volt supply bus attempts to decrease; the voltage at pin 3 of IC1 will decrease while the voltage at pin 2 remains constant. The decreasing voltage at pin 3 will cause the reference amplifier output voltage at pin 6 to decrease the forward bias of Q19. The collector voltage of Q19, the forward bias of Q18 and the base current of Q17 will increase. The collector-to-emitter voltage of Q17, which is in series

Horizontal Hold/Oscillator Adjustment

Adjust the core of HOR. SET coil L1 until the horizontal blanking lines are vertical or the CRT display is stable (synced).

Vertical Height/Linearity Adjustment

1. Connect a test generator whose output is similar to the display signal normally used.

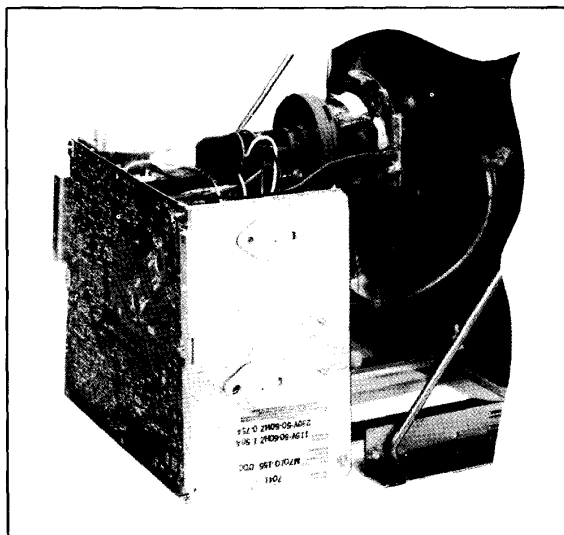

Figure 6-1 Motorola Monitor Circuit Board in Service Position

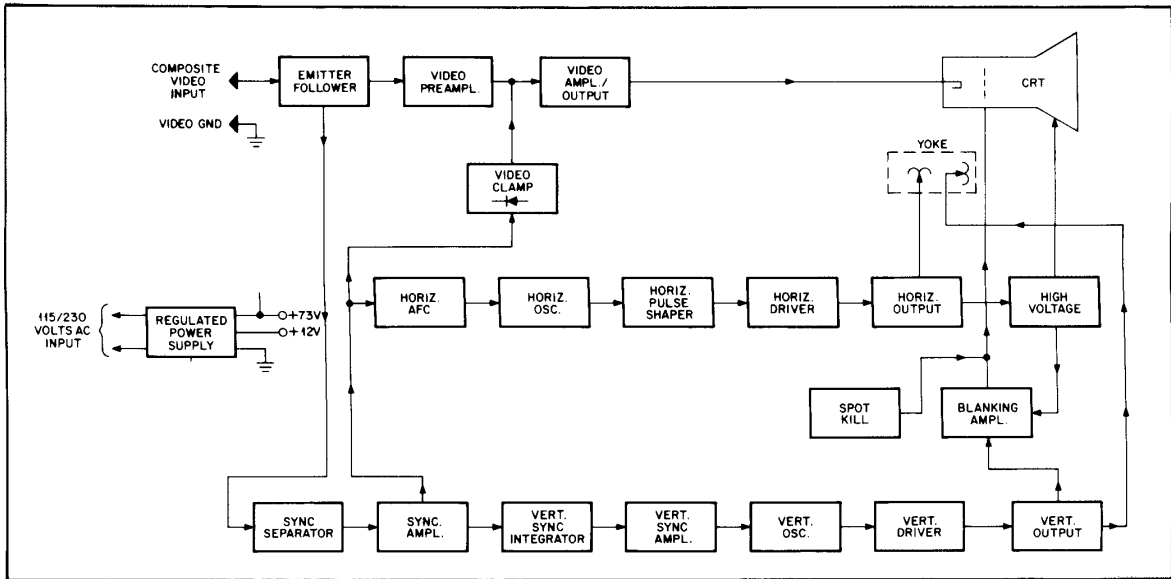

Figure 6-2 Motorola Monitor Block Diagram

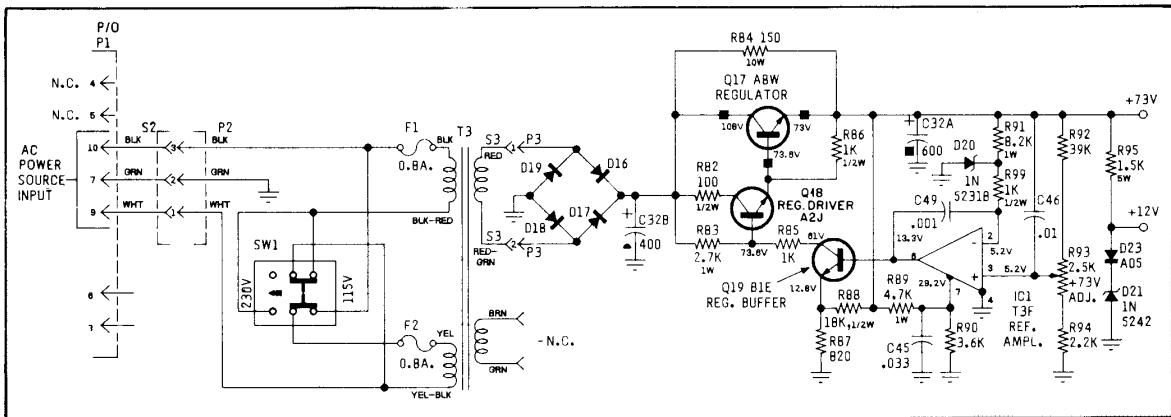

Figure 6-3 +73 Volt Supply Circuit

with the output, will decrease proportionally to the attempted decrease in the output bus.

Resistor R84 shunts a portion of the output current around Q17 so less power is dissipated within the device. Resistor R82 is the current-limiting resistor for Q18, and R86 controls the leakage current of Q17. Resistors R83 and R85 are the collector load for Q19, and R88 and R87 provide an emitter voltage for Q19 within the range of IC1's output voltage variations. Capacitor C45 filters high frequency variations from the voltage at pin 7 of IC1, and C49 is a Miller-effect capacitor which eliminates instability.

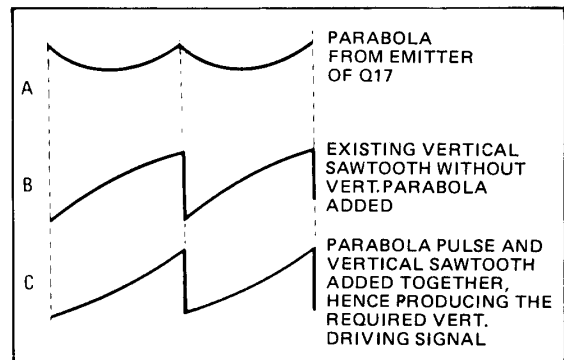

Figure 6-4 Motorola Monitor Vertical Drive Waveform

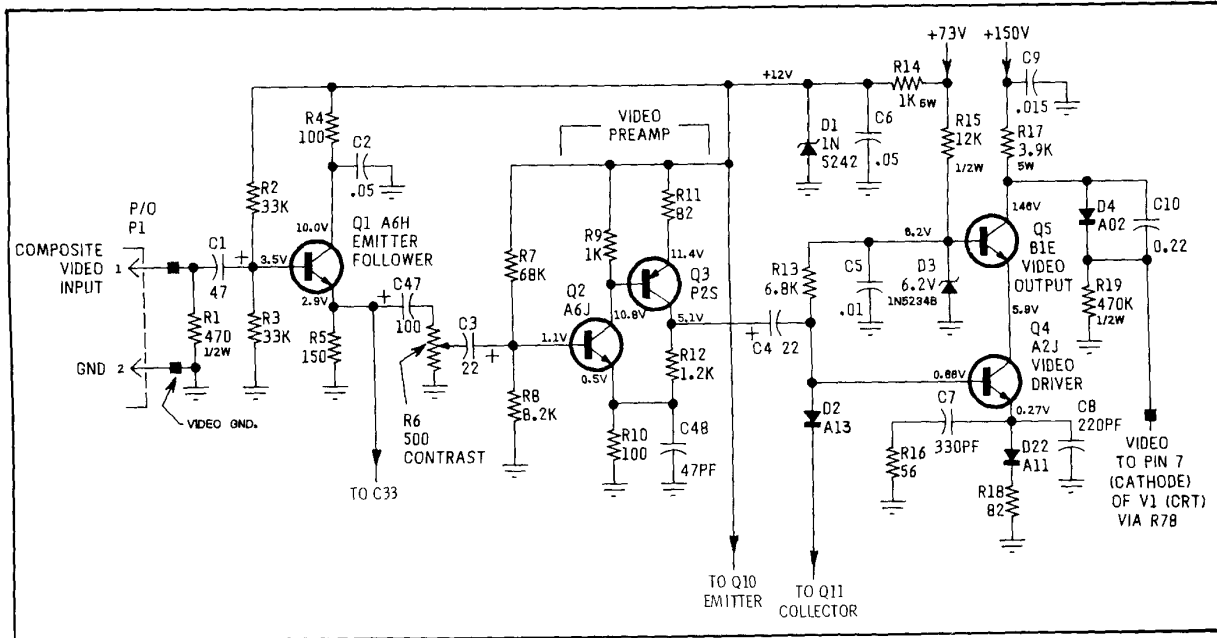

Figure 6-5 Motorola Monitor Video Amplifiers and Output Circuit

Capacitor C32A filters horizontal frequency variations from the output bus.

Resistor R91 provides bias current for D20, and the value of R99 presents an impedance from pin 2 of IC1 to AC ground (through D20). Capacitor C46 couples high frequency voltage variations, which occur at the output bus, back to pin 3—preventing oscillations for proper operation of the reference amplifier. Resistors R92, R93, and R94 provide voltage division such that the adjustment of R93 can be set equal to the voltage of pin 2 of IC1. Resistor R95 provides bias current for D21 and also provides the +12 volt output. Diode D23 is necessary to temperature-compensate for variations within D21. Capacitor C32B filters AC variations from the output of the full-wave bridge.

Video Amplifiers and Output (See Figure 6-5)

The composite video signal is coupled to the emitter-follower Q1 through the input connector P1 and capacitor C1. Transistor Q1 is a buffer stage which matches the impedance of the signal source to the video preamplifier and the sync separator stages. Resistor R1 is a terminating resistor for the video signal source, and resistors R2, R3, R4, and R5 form the biasing network for the stage. Capacitor C2 bypasses higher video frequencies to ground. The

composite video signal is coupled from the emitter of Q1 to the sync separator Q10 through C33 and to the contrast control R6 through C47.

The contrast control varies the amplitude and couples the composite video signal to the base of Q2 through capacitor C3. Transistors Q2 and Q3 are complementary, direct-coupled, common emitter amplifiers. The voltage gain (approximately 12) of the preamplifier stage is controlled by the feedback arrangement of R9, R10, R11, and R12. Resistors R7 and R8 provide the base bias voltage for Q2. Capacitor C48 is used for high-frequency peaking.

The output of the video preamplifier stage is coupled to the video output stage through capacitor C4. Diode D2 clamps the video signal to approximately +0.7 volts (DC restoration) when a sync pulse turns on the sync amplifier Q11. The video output stage is connected in a cascade configuration. Transistor Q4 is a common emitter amplifier and Q5 is connected in a common base arrangement. Capacitors C7, C8, and resistor R16 are used for high-frequency compensation, and resistor R18 controls the gain of the stage to approximately 47. Diode D3 maintains the base of Q5 at +6.2 volts, while capacitor C5 filters the video signal variations from the base voltage. Resistor R13 provides a DC bias path for D2, and R19 and D4 are used to limit the current through the CRT.

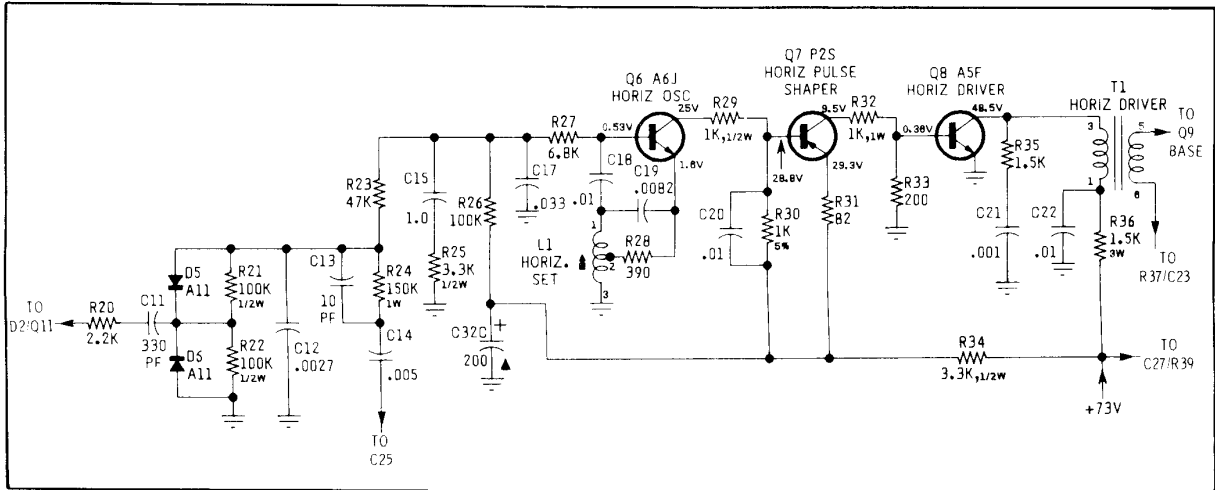

Figure 6-6 Motorola Monitor Horizontal Deflection Circuit

Capacitor C10 AC-couples the video from the collector of Q5 to the cathode of the CRT if D4 turns off due to high beam currents. Resistor R17 is the collector load for Q5, and R15 provides the bias current for the zener diode D3. Capacitors C9 and C6 filter video frequencies from the +150 volt and +12 volt supplies. Resistor R14 and zener diode D1 are used to supply +12 volts for Q1, Q2, and Q3.

D. HORIZONTAL DEFLECTION CIRCUITS (See Figure 6-6)

Phase Detector (See Figure 6-7)

The phase detector consists of two diodes (D5 and D6) in a keyed clamp circuit. Two inputs are required to generate the required output, one from the horizontal sync amplifier, Q11, and one from the horizontal output circuit, Q9. The required output must be of the proper polarity and amplitude to correct phase differences between the input horizontal sync pulses and the horizontal time base.

The horizontal output (Q9) collector pulse is integrated into a sawtooth by R24 and C12. During horizontal sync time, diodes D5 and D6 conduct, which shorts C12 to ground. This effectively clamps the sawtooth on C12 to ground at sync time. If the horizontal time base is in phase with the sync (waveform A), the sync pulse will occur when the sawtooth is passing through its AC axis, and the net charge on C12 will be zero (waveform B). If the horizontal time base is lagging the sync, the sawtooth on C12 will be clamped to ground at a point negative from the AC axis. This will result in a positive DC charge on C12 (waveform C). The positive polarity

causes the horizontal oscillator to speed up and correct the phase lag. Likewise, if the horizontal time base is leading the sync, the sawtooth on C12 will be clamped at a point positive from its AC axis. This results in a net negative charge on C12 which is the required polarity to slow the horizontal oscillator (waveform D).

Components R23, C15, R25 and C17 comprise the phase detector filter. The bandpass of this filter is chosen to provide correction of horizontal oscillator phase without ringing or hunting. Capacitor C13 times the phase detector for correct centering of the picture on the raster.

Horizontal Oscillator

The horizontal oscillator employs the principles of the Hartley-type oscillator. Its operating frequency is sensitive to its DC base input voltage, thus permitting the frequency of the oscillator to be varied by the output voltage of the phase detector. The main frequency-determining components are L1, C19, and R28. The oscillator operates as a switch being biased alternately into saturation and cut-off. The initial forward starting bias is supplied via R26.

Horizontal Pulse Shaper and Driver

The horizontal pulse shaper Q7 serves as a buffer stage between the horizontal oscillator and driver. Capacitor C20 and resistor R30 combine to shape the input waveform to the required duty cycle of 50%, which is necessary to drive the horizontal output stage.

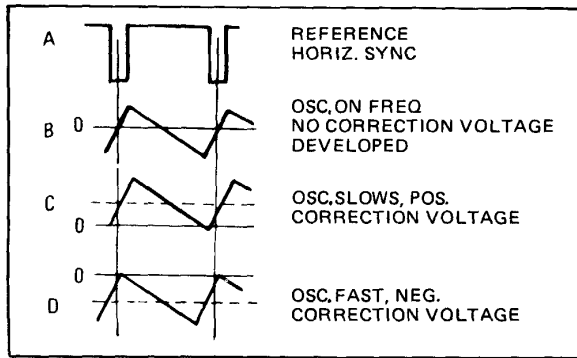

Figure 6-7 Motorola Monitor Horizontal Deflection Waveforms

The horizontal driver Q8 operates as a switch to driving horizontal output transistor Q9 through T1. Because of the low impedance drive and fast switching times, very little power is dissipated in Q8.

Resistor R35 and capacitor C21 provide damping to suppress ringing in the primary of T1 when Q8 goes into cut-off. Resistor R36 is used for limiting current in the collector of Q8, and C22 filters the horizontal frequency variations from the DC side of the transformer primary.

Horizontal Output (See Figure 6-8)

The secondary of T1 provides the required low drive impedance for Q9. Resistor R37 limits current in the base of Q9, while capacitor C23 provides additional reverse bias to keep Q9 turned off during the horizontal retrace pulse. Transistor Q9 operates as a switch which once each horizontal time period connects the supply voltage across the parallel combination of the horizontal deflection yoke and the primary of T2. The required sawtooth deflection current through the horizontal yoke is formed by the L-R time constant of the yoke and output transformer primary. The horizontal retrace pulse charges C27 through D8 to provide operating voltage for G2 of the CRT. Momentary transients at the collector of Q9, should they occur, are limited to the voltage on C27, since D8 will conduct if the collector voltage exceeds this value.

The damper diode D7 conducts during the period between retrace and turn-on of Q9 to reduce retrace overshoot; capacitor C28 is the retrace tuning capacitor. Capacitor C25 blocks DC from deflection yoke. Components R38 and C26 are damping components for the width and linearity coils. Capacitor C32D is charged through D10, developing the video supply voltage.

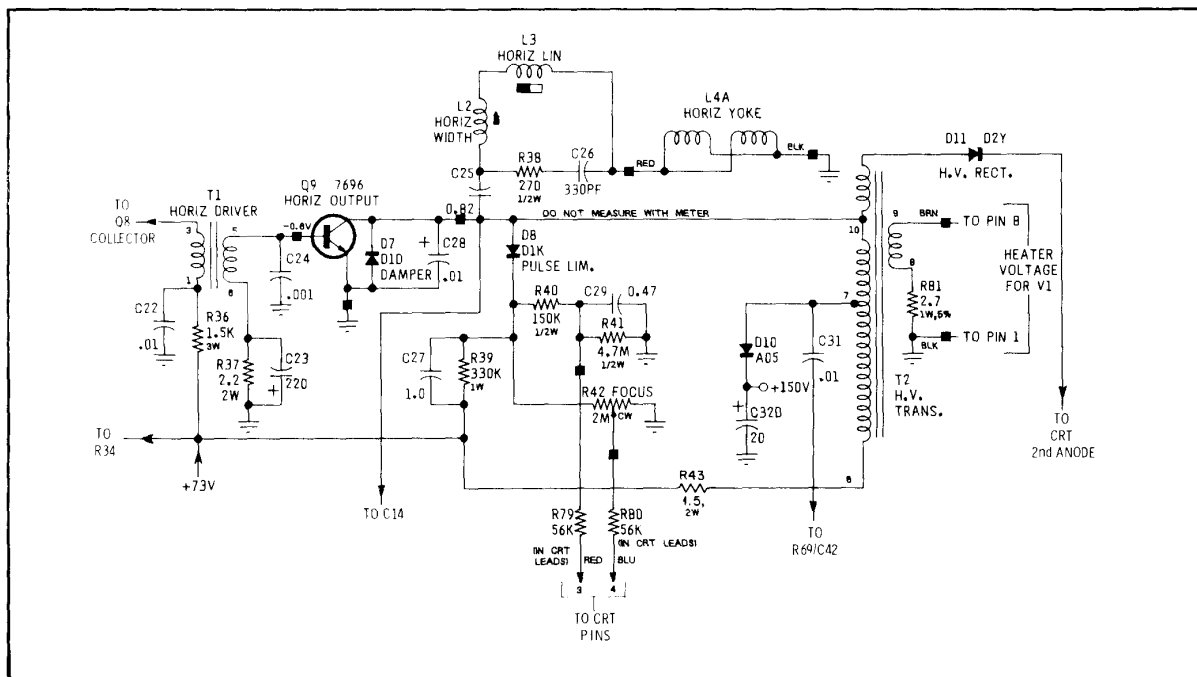

Figure 6-8 Motorola Monitor Horizontal Output Circuit

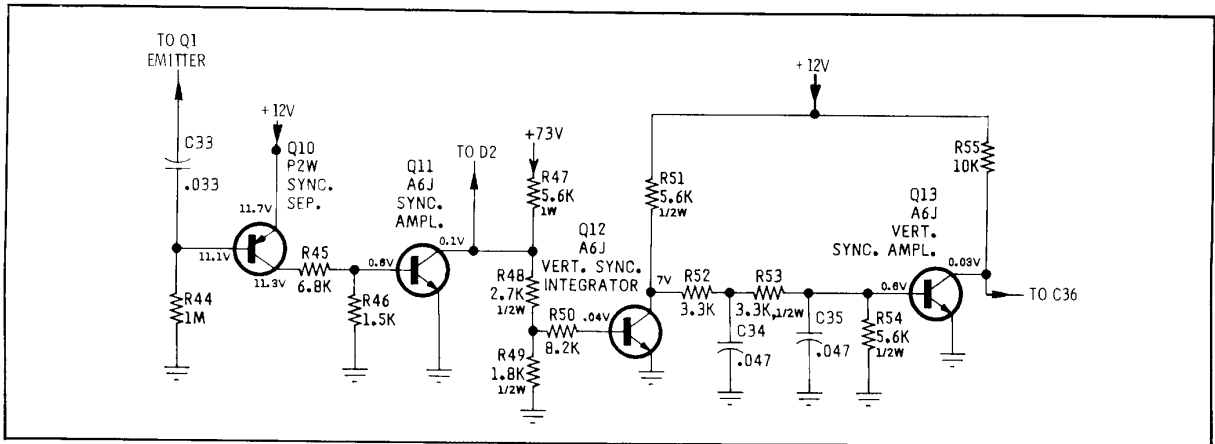

Figure 6-9 Motorola Monitor Sync Circuit

Sync Circuits (See Figure 6-9)

The video signal is coupled from the emitter of Q1 to the base of Q10 through C33. The negative-going sync tips turn on Q10 and are clamped to the value of the base voltage due to the base-emitter diode junction. The video information within the composite video signal, however, is less negative and Q10 remains off between each sync tip. Therefore, the waveform at the collector of Q10 will contain only the composite sync pulse information.

Resistors R45 and R46 provide base bias for Q11. The composite sync pulses are amplified and inverted by Q11 where they are coupled to the vertical sync

integrator Q12, the horizontal phase detector, and the video clamp diode D2. Resistors R47, R48, and R49, are the collector load for Q11, and also provide base bias for Q12. Resistor R50 limits current through the base-emitter junction of Q12, and R51 is its collector load. Components R52, C34, R53, C35, and R54 form a double integrator which removes the horizontal pulses from the composite sync signal, leaving the vertical pulses to be amplified by Q13 and coupled to the vertical oscillator.

Vertical Oscillator and Output (See Figure 6-10)

The vertical oscillator is a relaxation oscillator and operates at a free-running frequency that is set by

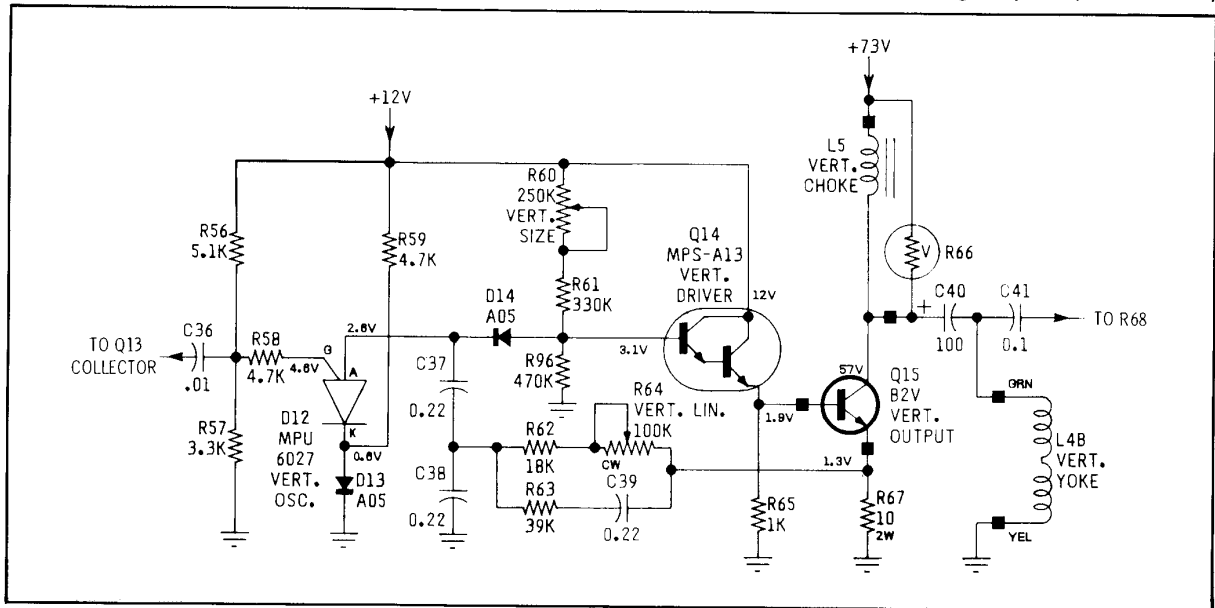

Figure 6-10 Motorola Monitor Vertical Oscillator Circuit

the value of resistors R56 and R57. The series combination of C37 and C38 charges through D14, R61, and R60, until D12 turns on. This occurs when the anode voltage of D12 exceeds the gate voltage by approximately 1.0 volt. When D12 conducts, C37 and C38 are discharged to nearly zero volts; then D12 turns off and the cycle repeats. The value of R61 and the setting of R60 determines the amplitude of the waveform.

Diode D14 provides a small incremental voltage above ground to overcome the forward base-emitter drop of Q14; D13 provides temperature compensation for the output stage. Resistor R96 provides a constant oscillator load for variations in input impedance of Q14. Transistor Q14 is an emitter-follower used to transform the high impedance drive sawtooth to a low impedance drive for Q15.

The vertical choke L5 acts as a current source during linear scan time and provides a high-voltage pulse to aid retrace when Q15 shuts off. To limit this pulse to a safe value, a varistor, R66, is connected across the choke.

Since the impedance of the choke decreases when the collector current of Q15 increases, severe vertical non-linearity will result unless some compensation is employed.

Resistors R64 and R62 couple the emitter voltage of Q15 to the junction of C37 and C38. This path is resistive, and the waveform coupled back will be integrated by C38. This results in a pre-distortion of the drive sawtooth. This is done to compensate for the non-linear charging of C37, C38 and the changing impedance of C5. An additional feedback path through R63 and C39 serves to optimize the drive waveshape for best linearity. Capacitor C40 couples the signal to the vertical yoke winding and blocks DC.

Spot Kill (See Figure 6-11)

The spot kill circuitry is used to reduce the effect of the electron beam concentrating on one area of the CRT after the monitor is turned off. The circuitry is accomplished by raising the arm of potentiometer R73 to the +150 volt level and, therefore, increasing the brightness to maximum to dissipate the high-voltage charge that normally remains in the CRT.

When the monitor is operating, transistor Q20 is on and its collector is near zero volts. Capacitor C44 charges through the base-emitter junction of Q20 and R97. Resistor R72 provides the base bias voltage required to keep Q20 on. When the monitor is turned

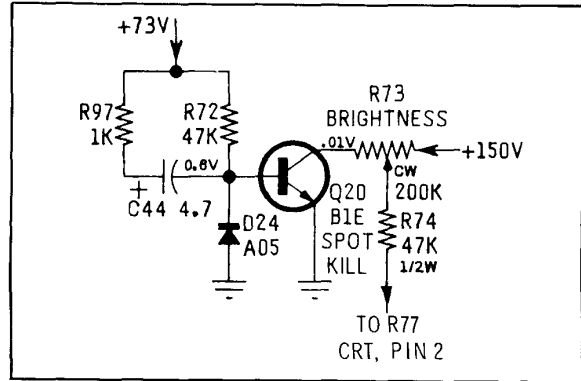

Figure 6-11 Motorola Monitor Spot Killer Circuit

off, the falling +73 volts is coupled to the base of Q20 to turn off the transistor causing its collector voltage to rise to approximately +150 volts. Diode D24 prevents the negative voltage swing at the base of Q20 from exceeding the reverse voltage rating of the transistor.

Blanking Amplifier (see Figure 6-12)

The blanking amplifier combines both the vertical and horizontal retrace pulses to turn off the electron beam in the CRT once every horizontal line and once every vertical field.

Capacitor C41 couples the vertical retrace pulses and capacitor C31 couples the horizontal retrace pulses to the blanking amplifier. Resistor R68 determines the amplitude of the vertical pulses, while R69 determines the amplitude of the horizontal pulses. Capacitor C42 bypasses R69 to couple the leading and trailing edges of the horizontal retrace pulses to the amplifier. Resistor R70 allows C41 to discharge when the retrace pulses swing below zero volts. Diode D15 prevents the retrace overshoot from exceeding the reverse voltage rating of Q20. Resistor R71 permits Q20 to turn off between retrace pulses, while R75 and R76 provide the collector voltage for Q20. Capacitor C43 couples the blanking pulses to the control grid of the CRT.

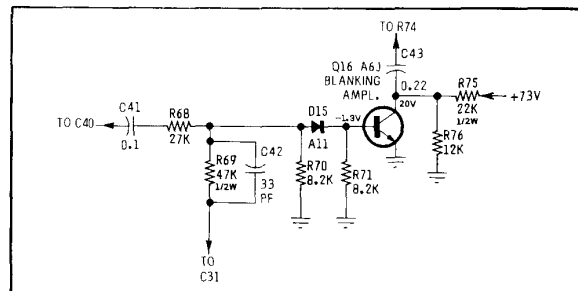

Figure 6-12 Motorola Monitor Blanking Amplifier Circuit

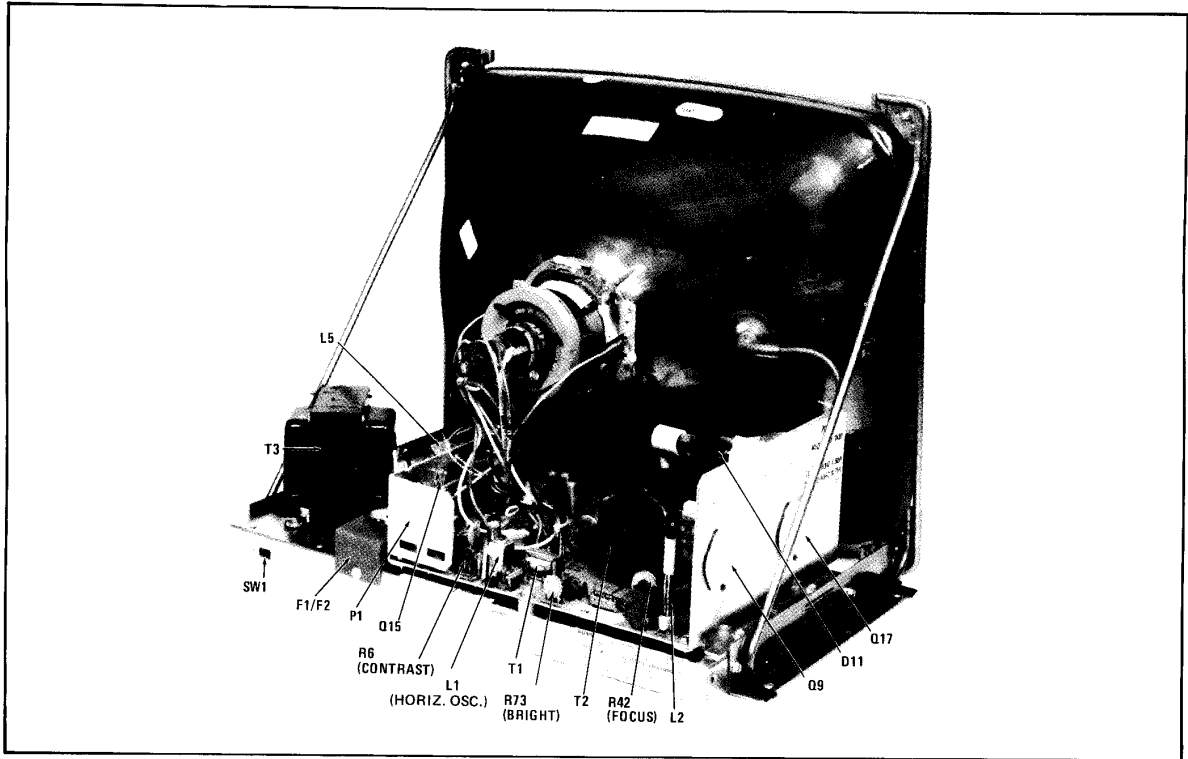

Figure 6-13 Motorola Monitor Chassis Rear View —Component Location

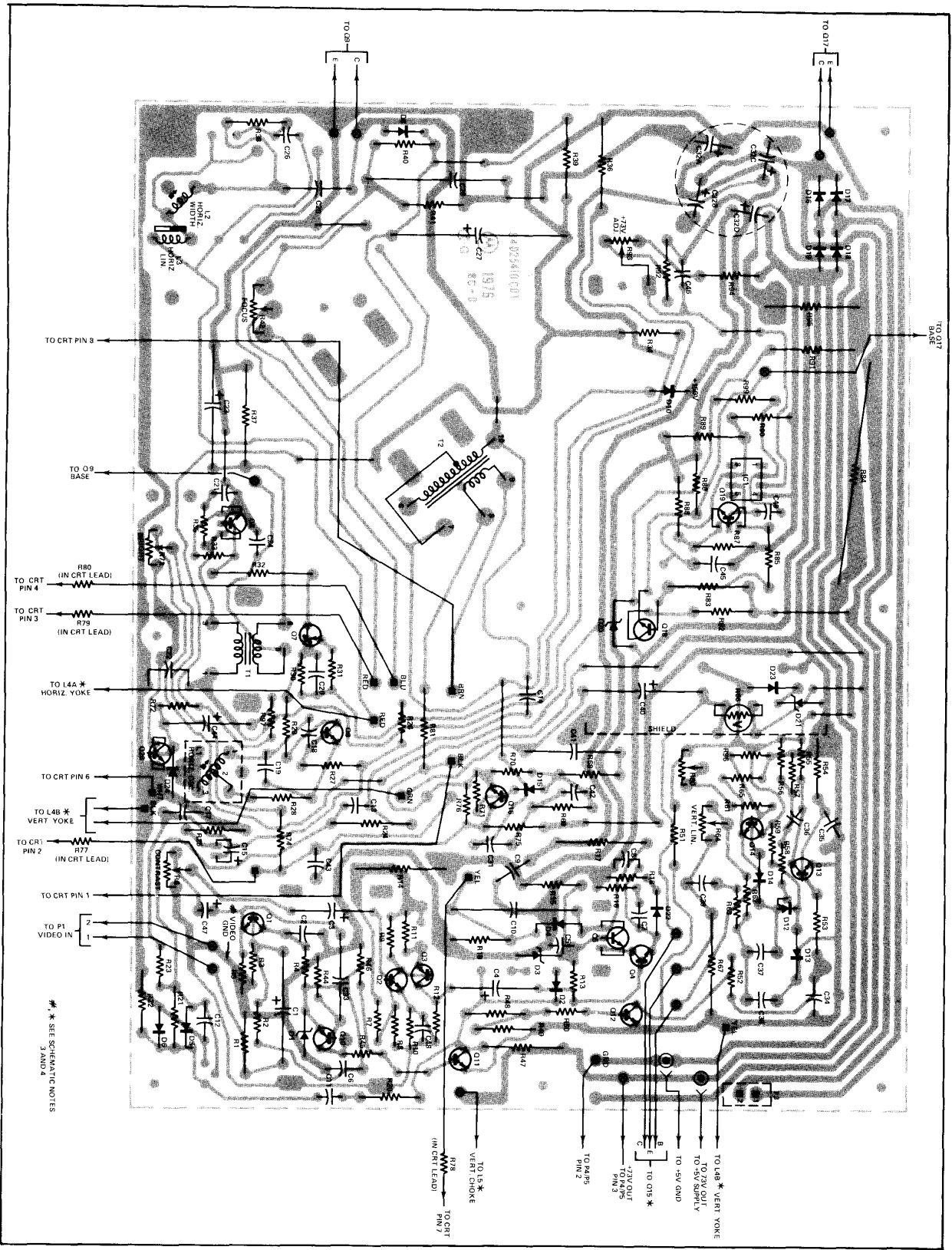

Figure 6-14 Motorola Monitor Circuit Board Detail—Solder View

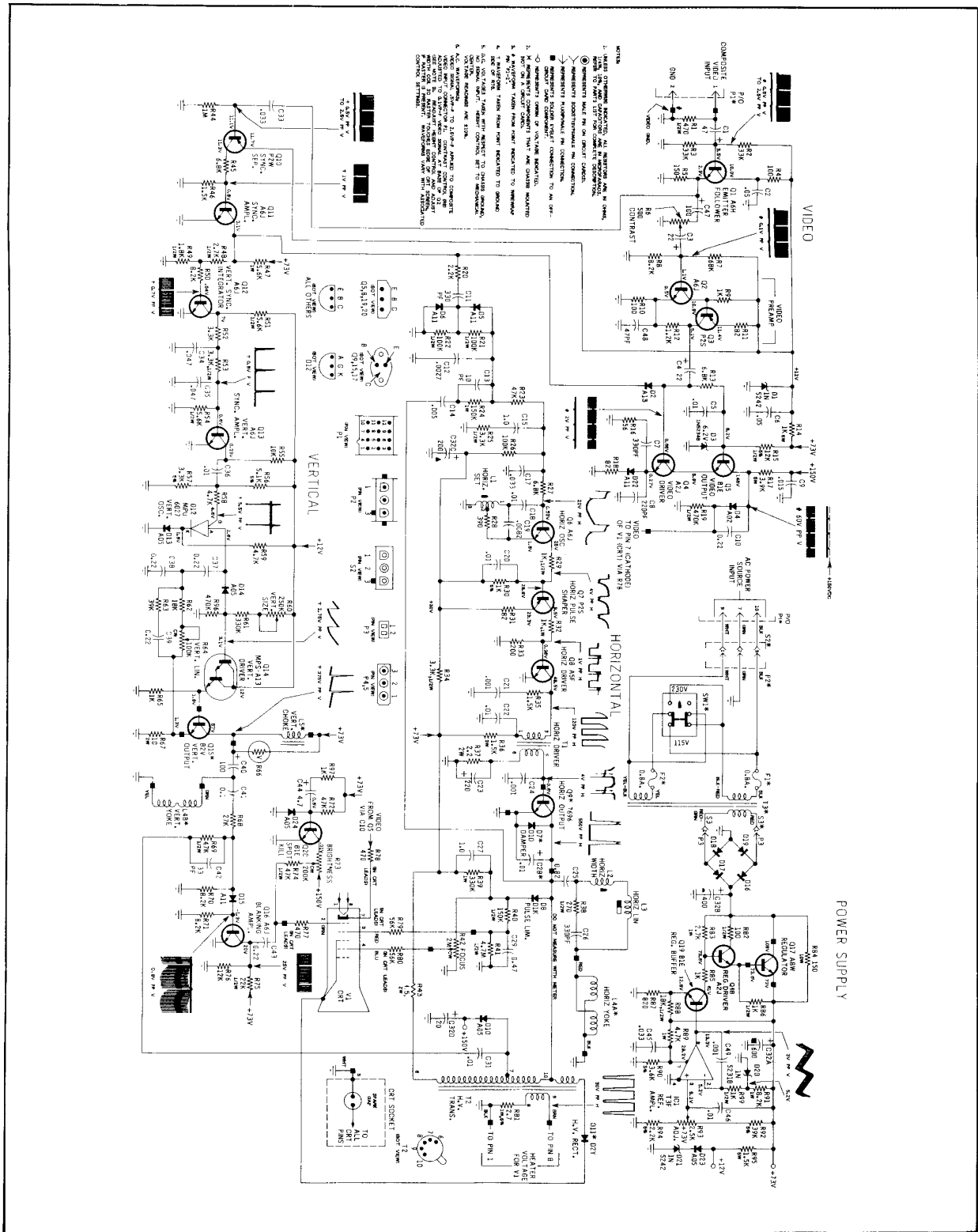

Figure 6-15 Motorola Monitor Schematic Diagram

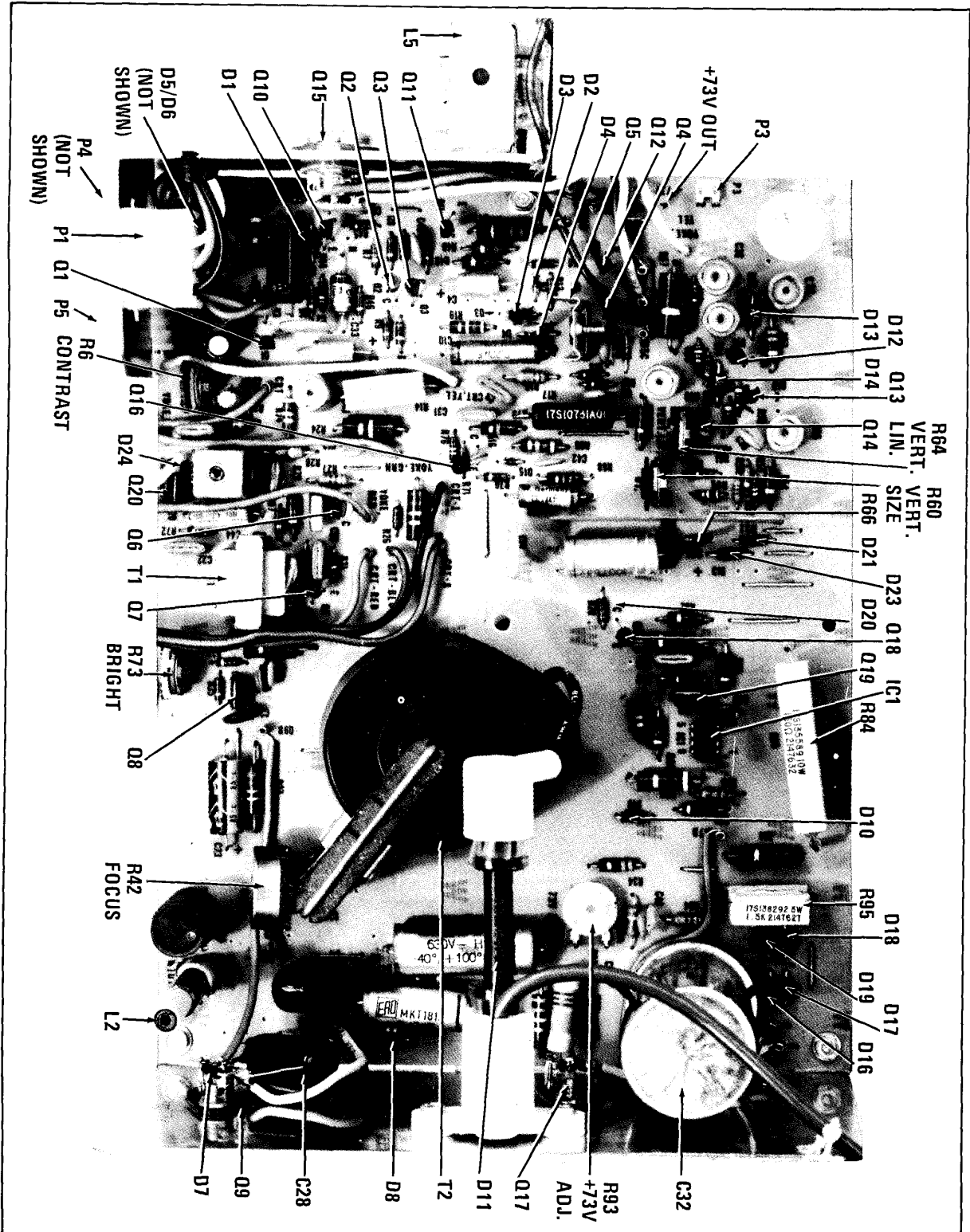

Figure 6-16 Motorola Monitor Circuit Board Detail—Component Location

Table 6-2 Motorola Replacement Part Numbers

REF. NO.	PART NUMBER	DESCRIPTION	REF. NO.	PART NUMBER	DESCRIPTION
Capacitors: All values are in Microfarads unless otherwise noted.			C31	8S10191B98	.01, 10%, 250V; Poly.
C1	23S10255A27	47, 50V; Lytic	C32	23S10255B73	20/200, 400/125, 600/100, 200/50; Lytic
C2	21S135660	.05, +80-20, Z5V, 50V; Cer. Disc.	C33	8S10191A51	.033, 10%, 160V; Poly.
C3, C4	23S187A26	22, 25V; Lytic	C34, C35	8S10191A32	.047, 10%, 250V; Poly.
C5	21S180E60	.01, +80-20; Z5V, 50V; Cer. Disc.	C36	21S180E60	.01, +80-20, Z5V, 50V; Cer. Disc.
C6	21S135660	.05, +80-20, Z5V, 50V; Cer. Disc.	C37, 38, 39	8S10191B67	0.22, 10%, 250V; Poly.
C7	21S131625	330pf, 10%, X5F, 500V; Cer. Disc.	C40	23S10255A60	100, 63V; Lytic
C8	21S180B87	220pf, 10%, X5F, 500V; Cer. Disc.	C41	8S10212B16	0.1, 20%, 400V; Mtlz. Poly.
C9	8S10191B99	.015, 10%, 250V; Poly.	C42	21S180C82	0.33, 10%, N150, 500V; Cer. Disc.
C10	8S10212B18	0.22, 10%, 400V; Mtlz. Poly.	C43	8S10191B67	0.22, 10%, 250V; Poly.
C11	21S131625	330pf, 10%, X5F, 500V; Cer. Disc.	C44	23S10255B28	4.7, 100V; Lytic
C12	21S180C41	.0027, 10%, Z5F, 500V; Cer. Disc.	C45	8S10191B90	.033, 10%, 250V; Poly.
C13	21S180C02	10pf, 10%, N150, 500V; Cer. Disc.	C46	21S132492	.01, +80-20, Z5V, 100V; Cer. Disc.
C14	21S180D34	.005, 20%, Z5F, 1KV; Cer. Disc.	C47	23S10255B63	100, 10V; Lytic
C15	23S10229A32	1.0, 16V; Lytic	C48	21S180D56	47pf, 10%, N750, 100V; Cer. Disc.
C17	8S10191B90	.033, 10%, 250V; Poly.	C49	21S180B51	.001, 10%, X5F, 500V; Cer. Disc.
C18	8S10299B28	.01, 10%, 100V; Polycarb.	Diodes:		
C19	8S10299B29	.0082, 10%, 100V; Polycarb.	D1	48S10813A03	Diode, Silicon, Zener; IN5242
C20	8S10191B98	.01, 10%, 250V; Poly.	D2	48D67120A13	Diode; A13
C21	21S180B51	.001, 10%, X5F, 500V; Cer. Disc.	D3	48S10813A01	Diode, Silicon, Zener; IN5234B
C22	8S10191B98	.01, 10%, 250V; Poly.	D4	48S191A02	Rectifier, Silicon; 91A02
C23	23S10255B50	150, 10V; Lytic	D5, D6	48D67120A11	Diode; A11
C24	21S180B51	.001, 10%, X5F, 500V; Cer. Disc.	D7	48S134921	Diode, Damper; D1D
C25	8S10299B27	0.82, 10%, 200V; Mtlz. Polycarb.	D8	48S134978	Diode, Pulse Lim; D1K
C26	21S131625	330pf, 10%, X5F, 500V; Cer. Disc.	D10	48S191A05	Rectifier, Silicon; 91A05
C27	8S10212A11	1.0, 10%, 630V; Mtlz. Poly.	D11	48S137114	Rectifier, H.V., D2Y
C28	8S10571A06	.01, 5%, 1200V; Polyprop. Foil	D12	48S137638	Vert. Osc.; MPU6027
C29	8S10212B53	0.47, 10%, 630V; Mtlz. Poly.	D13, D14	48S191A05	Rectifier, Silicon; 91A05
			D15	48D67120A11	Diode; A11
			D16, D17, D18, D19	48S191A05	Rectifier, Silicon; 91A05
			D20	48S10813A02	Diode, Silicon, Zener; 1N5231B
			D21	48S10813A03	Diode, Silicon, Zener; 1N5242
			D22	48D67120A11	Diode; A11
			D23, D24	48S191A05	Rectifier, Silicon; 91A05

Table 6-2 Motorola Replacement Part Numbers

Ref. No.	Part No.	Description	Ref. No.	Part No.	Description
Fuses:			R60	18D25245A29	Vert. Size; 250K
F1, F2	65S138269	Fuse, 0.8A-250V	R64	18D25245A31	Vert. Lin.; 100K
Integrated Circuits:			R66	6S10201A04	Varistor, 1 ma, 120V, 0.5W
IC1	51S10732A01	Ref. Ampl.; T3F	R73	18D25245A28	Control, Brightness; 200K
Coils/Chokes:			R84	17S135589	150, 10%, 10W
L1	24C25448A01	Coil, Horiz. Osc.	R93	18D25245A21	Control, +73V out Adj.; 2.5K
L2	24D25603A09	Coil, Horiz. Width	R95	10731A03	1.5K, 10%, 5W
L3	24D25248A14	Coil, Horiz. Lin.	Switches:		
L4	24D25261A09	Coil, Defl. (M5000-155, M5010-155)	SW1	40S10624A07	Switch, Slide; D.P. D.T.
L4	24D25261A10	Coil, Defl. (M7000-155, M7010-155)	Transformers:		
L5	25D25221C12	Choke, Vertical	T1	25D25221A05	Horiz. Driver
Transistors:			T2	24D25240B23	H.V. Transformer
Q1	48S137171	Emitter Follower; A6H	T3	25D25239B20	Transformer, Power (M5010-155, M7010-155)
Q2	48S137172	Video Pre-Ampl.; A6J	T3	25D25239B30	Transformer, Power (M5000-155, M7000-155)
Q3	48S137127	Video Pre-Ampl.; P2S	Misc. Electrical Parts:		
Q4	48S134952	Video Driver; A2J	V1	96S241A01	19"-CRT; Type 19VARP4 (M5000/M5010)
Q5	48S137476	Video Output; B1E	V1	96S10848A01	23"-CRT; Type M22VATP4 (M7000/M7010)
Q6	48S137172	Horiz. Osc.; A6J	Mechanical Parts:		
Q7	48S137127	Horiz. Pulse Shaper; P2S		9B25456A01	Block, Fuse (F1, 2)
Q8	48S137093	Horiz. Driver; A5F		42D25158C01	Clamp, Defl. Coil
Q9	48S137570	Horiz. Output; B2L		26S10251A08	Heat Sink (Q5)
Q10	48S137173	Sync Separator; P2W	P1	15S10183A69	Housing, Connector; Female (12-Contact, Less Contacts)
Q11	48S137172	Sync Ampl.; A6J		39S10184A67	Contact, Plug; 5 Req'd M5000/M7000, 9 Req'd; M5010/M7010
Q12	48S137172	Vert. Sync Integrator; A6J	P2	15S10183A82	Housing, Connector; Male (3-Contact, Less Contacts), M5000/M7000
Q13	48S137172	Vert. Sync Ampl.; A6J	P2	15S10183A81	Housing, Connector; Female (3-Contact, Less Contacts), M5010/M7010
Q14	48S137639	Vert. Driver; MPS A13		39S10184A67	Contact, Plug; 3 Req'd for P2
Q15	48S137596	Vert. Output; B2V	P3	28S10586A35	Header, Connector; 2-Contact
Q16	48S137172	Blanking Ampl.; A6J			
Q17	48S137368	Regulator; A8W			
Q18	48S134952	Reg. Driver; A2J			
Q19	48S137476	Reg. Buffer; B1E			
Q20	48S137476	Spot Kill; B1E			
Resistors/Controls:					
NOTE: Only power or special resistors are listed. Use the description when ordering standard values of fixed resistors up to 2 watts.					
R6	18D25245A27	Control, Contrast; 500			
R14	17S135204	100, 10%, 5W			
R17	17S10731A01	3.9K, 5%, 5W			
R36	17S10130B07	1.5K, 10%, 3W			
R42	18D25218A14	Control, Focus; 2M			

Table 6-2 Motorola Replacement Part Numbers

REF. NO.	PART NUMBER	DESCRIPTION	REF. NO.	PART NUMBER	DESCRIPTION
P4, P5	15S10183B12	Housing, Connector; Female (3-Contact, Less Contacts) M5010/M7010		14B25459A01	Insulator, Fuse Cover (F1, 2)
	39S10184A84	Contact, Plug; 3 ea. Req'd for P5, M5010/M7010		14A562353	Insulator, Mica (Q9, Q15, Q17)
S2	15S10183A81	Housing, Connector; Female (3-Contact, Less Contacts), M5000/M7000		14C25230A01	Insulator, Molded (On D11 Body)
S2	15S10183A82	Housing, Connector; Male (3-Contact, Less Contacts), M5010/M7010		14S10157A30	Insulator, Nylon (2-Req'd.); Mtg. P.C. Board
	39S10184A64	Contact, Receptacle; 3 Req'd. for S2		14S10550A02	Insulator, Transistor Cover (Q9, Q15, Q17)
S3	15S10183A94	Housing, Connector; Female (2-Contact, Less Contacts)		3S136050	Screw, Tpg; 6-20x½ CLU Pan (Mtg. Q9, Q15, Q17 and D11 Socket)
	39S10184A72	Contact, Receptacle; 3 Req'd. for S3		9D25470A01	Socket, CRT; Incl's. R77, R78, R79, R80
				9D25201A01	Socket, H.V. and CRT Anode
				9C63825A03	Socket, Power Transistor Q9, Q15, Q17)
				41D65987A01	Spring Special; CRT Aquadag Gnd.