

**COIN  
MECHANISMS INC.**

817 INDUSTRIAL DRIVE  
ELMHURST, IL 60126  
312-279-9150

## Operation and Service Manual

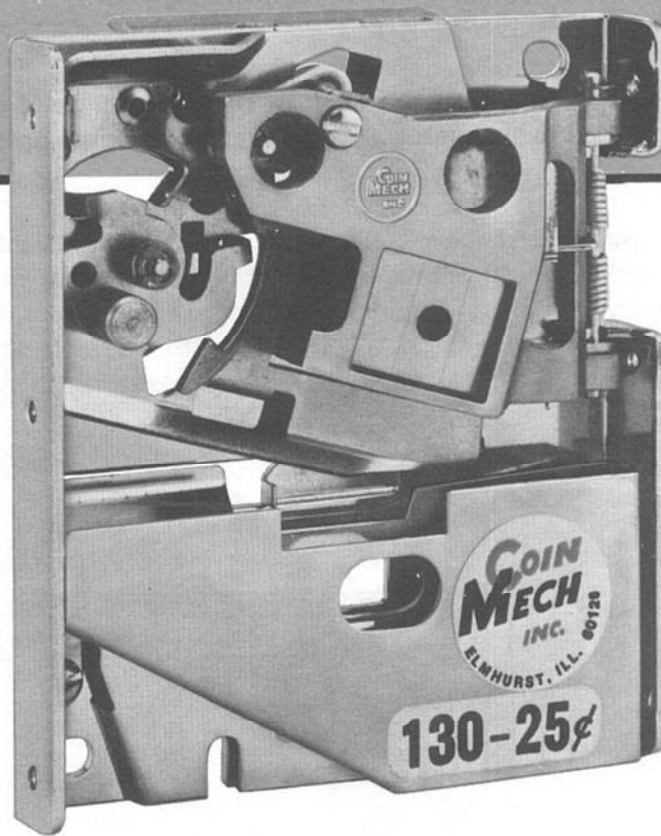

**100 SERIES COIN MECH.**  
DOMESTIC, FOREIGN & TOKEN MECHS.

## OPERATION

The “Series 100” Coin Mechanisms are designed to require a minimum of maintenance and field adjustment. Detection and rejection of undesired or counterfeit coins are determined by size (both thickness and diameter), weight, metallic content, and bounce.

Cradles are used to test the size of the coin. Undersize diameter coins will pass between the legs of the cradle and will be returned. Oversize diameter coins will fail to pass between the cradle and the diameter gauge and will be returned by actuating the wiper operating lever. In the case of the quarter acceptor, an undersize lever must first be pivoted to unlock the cradle. Undersize diameter “quarters” will fail to unlock the cradle and will be returned by actuating the wiper operating lever. Coins that are oversize in thickness will fail to pass between the magnet gate and the main channel and will have to be dislodged and returned by actuating the wiper operating lever.

Cradles are also used to test the weight of the coin. Underweight coins will fail to overcome the cradle counterweight and will be returned by actuating the wiper operating lever.

A magnet is used to test the metallic content of the coin. Highly magnetic coins, such as steel or iron, will be retained by the magnet and will be returned by actuating the wiper operating lever. Coins having comparatively high magnetic properties, such as copper, will be slowed down by the magnet and will drop off the end of the rail short of the “accept” entrance and be returned. Coins having little or no magnetic properties, such as brass or zinc, will pass through the magnetic field so fast that they will “overshoot” the “accept” entrance and be returned.

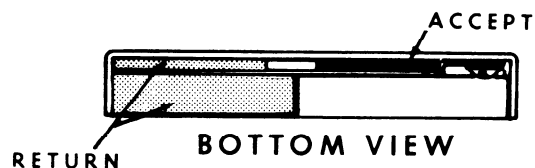

In the case of the Nickel Coin Mechanism, a bounce tester is used to test the bounceability of the coin. Due to its magnetic properties, a genuine nickel passes quickly through the magnetic field and drops off the end of the rail in an arc that causes it to hit the bounce tester which, because of the coin's elasticity, “bounces” it into the “accept” entrance. A counterfeit coin passing through the magnetic field at the same speed as a genuine nickel will not have the same elasticity and so will not have the same “bounce” as a genuine nickel and will miss the “accept” entrance and be returned.

### Serration Detector Ass'y (US – Canadian Mechs)

As coins pass the detector spring it senses the serration on the coin edge, therefore directing coin to accept side of mech.

# ADJUSTMENTS

All "Series 100" Coin Mechanisms leave the factory adjusted for maximum performance. If, however, more critical adjustments are desired, or if the unit has been completely disassembled for service, the following adjustment procedure is suggested:

## A. Separator Assembly (On Dime and Quarter Coin Mechanisms only)

Set the Coin Mechanism with the back of the unit facing you in the test position.

1. Loosen the screw holding the separator and move as far to the right as it will go. Tighten the screw.
2. Insert several coins (both old and new) and note that some are returned by striking the separator.
3. Loosen the separator screw and move the separator a slight amount to the left. Tighten the screw.
4. Insert the coins again and, if some of them are still returned, repeat Step 3 until all of the coins are accepted.

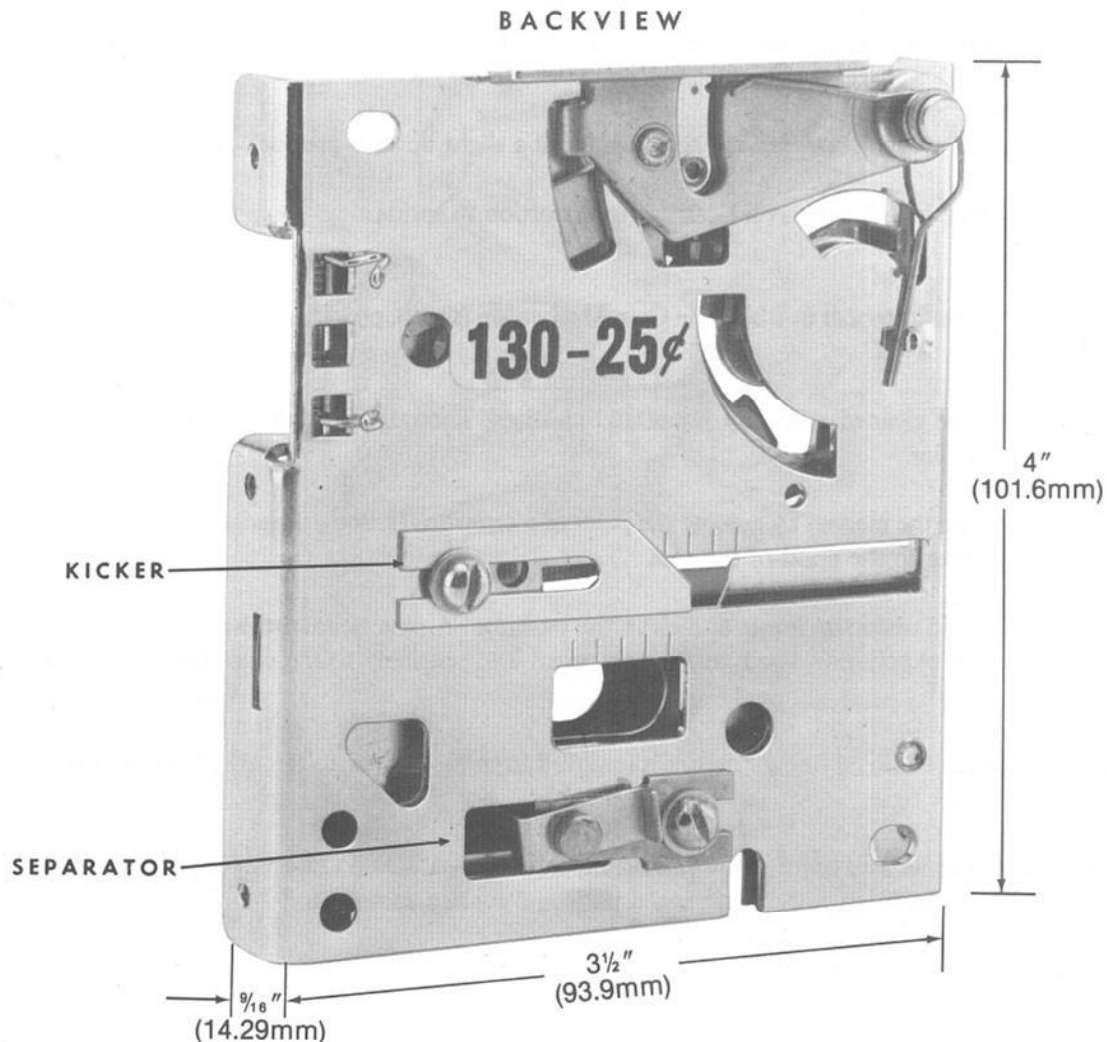

## ADJUSTMENTS — (Continued)

### B. Kicker

5. Loosen the kicker screw and move the kicker as far to the left as it will go. Tighten the Screw.
6. Insert several coins and note that some of them are returned.
7. Loosen the kicker screw and move the kicker a slight amount to the right. Tighten the screw.
8. Insert the coins again and, if some of them are still returned, repeat Step 7 until all of the coins are accepted.
9. Be sure the screws are tight after all adjustments are made.

### C. The diameter gauge adjustment

Loosen screw, move diameter gauge to left, insert new coin and move diameter gauge to right until the coin passes, then tighten screw.

### D. Magnet Gate Assembly

Turn thickness screw counter clockwise several turns or until coin hangs up (when dropped in) then turn screw clockwise until coin just passes, now turn 1/8 turn more.

### E. Serration Detector Ass'y (US — Canadian Mechs)

To Adjust: A slight pressure downward on serration spring will enable a greater variety including smooth edged coins to be accepted.

Should a coin become wedged between the spring and rail a slight upward pressure on spring is advised.

Caution and care must be taken to avoid damage or distortion to spring.

## MAINTENANCE

Depending upon the environment in which the Coin Mechanism is used, periodic preventive maintenance should be performed.

The mainplate may be cleaned with any household cleanser. Thorough rinsing and drying are necessary to remove deposits and/or film.

Remove all filings from the magnet by guiding the point of a screwdriver along the edges of the magnet. You will notice the filings will cling to the point of the tool.

Remove the cradles and undersize levers and clean the bushings. A pipe cleaner makes a good bushing cleaner. Also clean the pivot pin. Apply powdered graphite or pencil lead sparingly to the pivot pin and bushing and re-assemble.

On Nickel units make certain all foreign matter is removed from the bounce tester, also make certain the bounce tester fastening screws are tight.

In the event the recommended adjustment and maintenance procedures do not render your "Series 100" Coin Mechanism serviceable, check for worn or damaged parts and replace as necessary.

For service assistance or sales requirements, contact our office.

# 5¢ U.S.A. MECHANISM: N-110

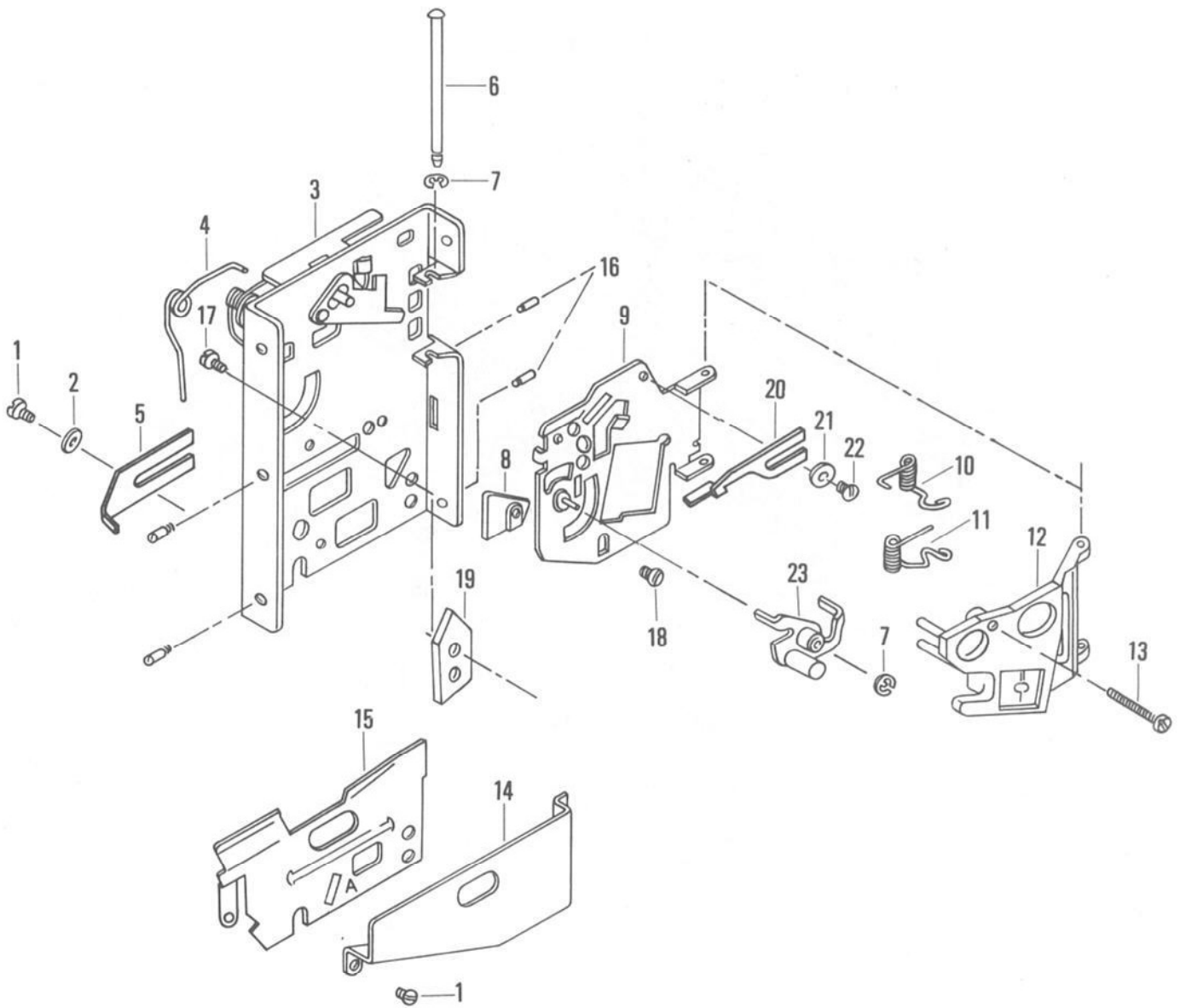

Part No.	Name of Part	Qty.
1.	188-6-2 6/32 x 1/8 R.H.M. Screw: Serr	2
2.	600-6 #6 Washer	1
3.	4042-1 5c Mainplate Ass'y	1
4.	1027 Oper. Lever Spring	1
5.	1009-1 Kicker	1
6.	1024 Gate Pivot Pin	1
7.	1046 "C" Washer	2
8.	1021 5c Rail	1
9.	4001 5c Gate Ass'y	1
10.	1028-1 Upper Gate Spring	1
11.	1029 Lower Gate Spring	1
12.	4015 White Magnet Gate Ass'y	1

Part No.	Name of Part	Qty.
13.	1032 Thickness Screw	1
14.	1004 Return Coverplate	1
15.	1005 "A" Coverplate	1
16.	1050 #6 Stud	4
17.	108-8-3 8-32 x 3/16 B.H.M. Screw	1
18.	108-6-5A 6-32 x 5/32 B.H.M. Screw	1
19.	1048 Anvil	1
20.	1013 Adj. Dia. Gauge	1
21.	600-4 #4 Washer	1
22.	100-4-2 4-36 x 1/8 R.H.M. Screw	1
23.	4017 5c Cradle Ass'y.	1

# D-120

10¢ U.S.A. MECHANISM:

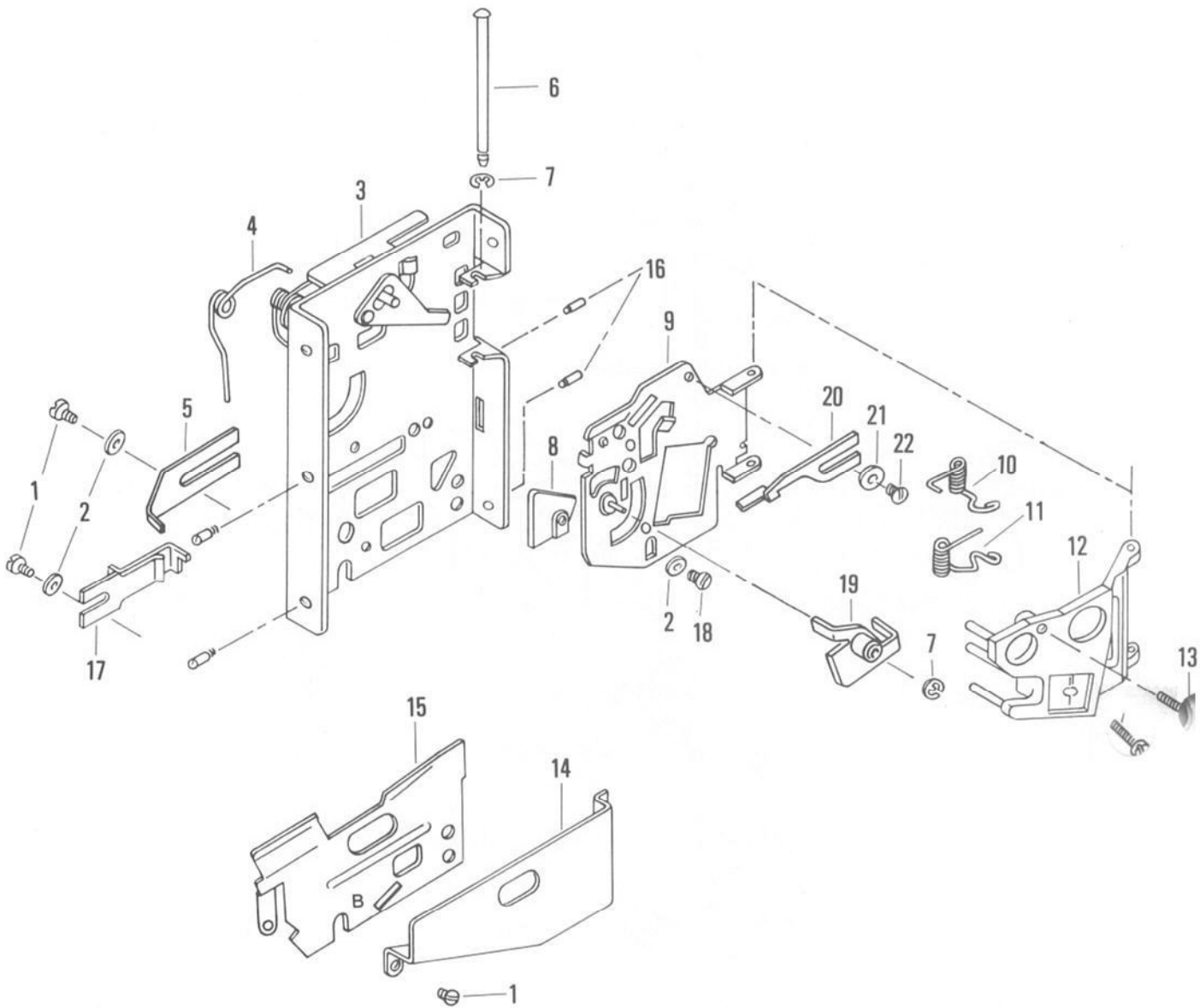

Part No.	Name of Part	Qty.
1.	188-6-2 6-32 x 1/8 R.H.M. Screw: Serr	3
2.	600-6 #6 Washer	3
3.	4010 10c Mainplate Ass'y	1
4.	1027 Oper. Lever Spring	1
5.	1009-1 Kicker	1
6.	1024 Gate Pivot Pin	1
7.	1046 "C" Washer	2
8.	1022 10c Rail	1
9.	4002 10c Gate Ass'y	1
10.	1028-1 Upper Gate Spring	1
11.	1029 Lower Gate Spring	1
12.	4014-1 Green Magnet Gate Ass'y	1
13.	1032 Thickness Screw	1

Part No.	Name of Part	Qty.
14.	1004 Return Coverplate	1
15.	1006 "B" Coverplate	1
16.	1050 #6 Stud	4
17.	4000 Separator Ass'y	1
18.	108-6-5A 6-32 x 5/32 B.H.M. Screw	1
19.	4009 10c Cradle Ass'y	1
20.	1013 Adj. Dia. Gauge	1
21.	600-4 #4 Washer	1
22.	100-4-2 4-36 x 1/8 R.H.M. Screw	1

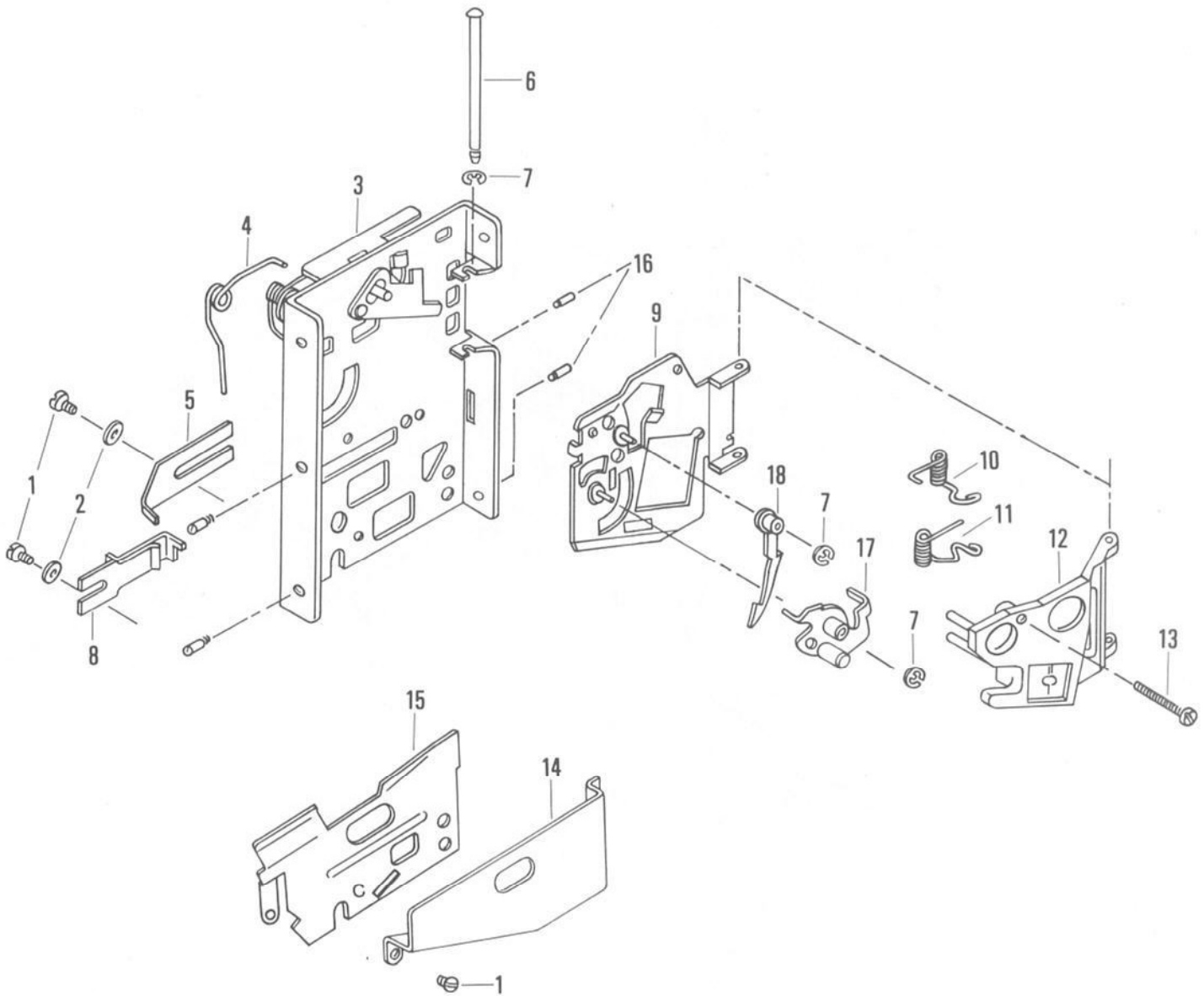

Part No.	Name of Part	Qty.
1.	188-6-2 6-32 x 1/8 R.H.M. Screw: Serr	3
2.	600-6 #6 Washer	2
3.	4042-1 25c Mainplate Ass'y	1
4.	1027 Oper. Lever Spring	1
5.	1009-1 Kicker	1
6.	1024 Gate Pivot Pin	1
7.	1046 "C" Washer	3
8.	4000 Separator Ass'y	1
9.	4008 25c Gate Ass'y	1
10.	1028-1 Upper Gate Spring	1
11.	1029 Lower Gate Spring	1
12.	4014 Green Magnet Gate Ass'y.	1
13.	1032 Thickness Screw	1

Part No.	Name of Part	Qty.
14.	1004 Return Coverplate	1
15.	1007 "C" Coverplate	1
16.	1050 #6 Stud	4
17.	4016-S 25c Cradle Ass'y.	1
18.	4004 Undersize Lever Ass'y	1

# 140-0 50¢ U.S.A. MECHANISM:

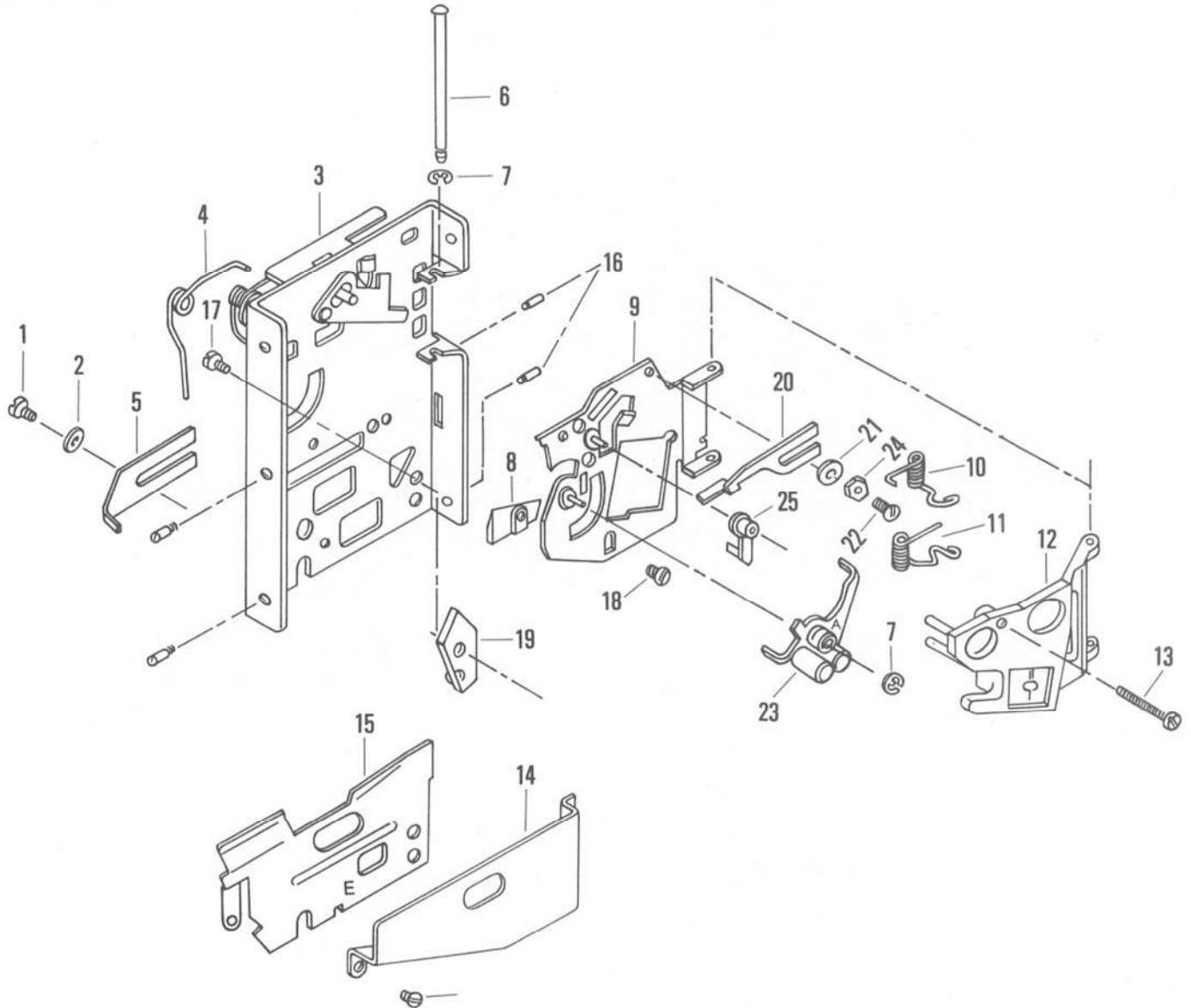

Part No.	Name of Part	Qty.	Part No.	Name of Part	Qty.
1.	188-6-2 6-32 x 1/8 R.H.M. : Serr. Screw	2	13.	1032 Thickness Screw	1
2.	600-6 #6 Washer	1	14.	1004 Return Cover Plate	1
3.	4042-1 25c Mainplate Ass'y. Long Pin	1	15.	1047 "E" Coverplate	1
4.	1027 Oper. Lever Spring	1	16.	1050 #6 Stud	4
5.	1009-1 Kicker	1	17.	108-8-3 8-32 x 3/16 B.H.M. Screw	1
6.	1024 Gate Pivot Pin	1	18.	108-6-5A 6-32 x 5/32 B.H.M. Screw	1
7.	1046 "C" Washer	3	19.	1059 Cut Anvil	1
8.	1021-1 5c Rail (Ground)	1	20.	1013 Adjustable Dia. Gauge	1
9.	4031 Gate Ass'y. (Cut)	1	21.	600-4 #4 Washer	1
10.	1028-1 Upper Gate Spring	1	22.	100-4-6 4-36 x 3/8 R.H.M. Screw	1
11.	1029 Lower Gate Spring	1	23.	4018-A 50c Cradle Ass'y.	1
12.	4014 Green Magnet Gate Ass'y.	1	24.	400-4 4-36 Hex Nut	1
			25.	4025 Cut Undersize Lever	1



# COIN MECHANISMS INC.

817 INDUSTRIAL DRIVE  
ELMHURST, IL 60126  
312-279-9150

150 S.B.A.\$

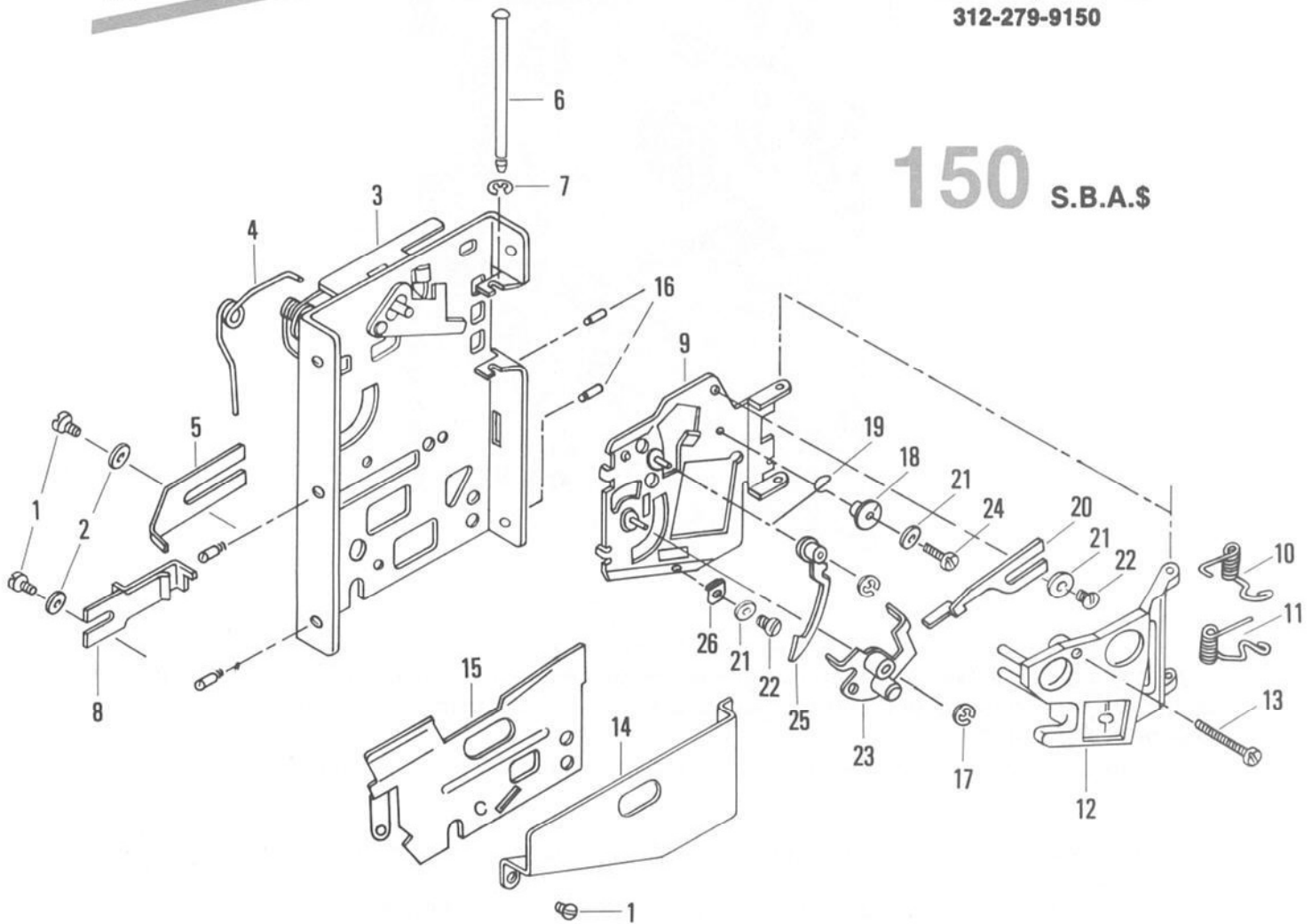

Part No.	Name Of Part	Qty.
1.	188-6-2 6-32 x 1/8 RHM Serr. Screw	3
2.	600-6 #6 5/16 x 1/32 Flat Washer	2
3.	4042-1 Long Pin 5/25¢/\$ Mainplate	1
4.	1027 Operating Lever Spring	1
5.	1009-1 Kicker	1
6.	1024 Gate Pivot Pin	1
7.	1046 "C" Washer	2
8.	4043 S.B.A.\$ Separator	1
9.	4044 S.B.A.\$ Gate-Staked	1
10.	1028-1 Upper Gate Spring	1
11.	1029 Lower Gate Spring	1
12.	4015 White Magnet Gate Ass'y	1
13.	1032 Thickness Screw	1
14.	1004 Return Coverplate	1
15.	1007 "C" Coverplate	1
16.	1050 #6 Stud	4
17.	1125 "C" Washer	1
18.	1120 Spring Retainer	1
19.	1121 U.S. Lever Spring	1
20.	1013 Adj. Dia. Gauge	1
21.	600-4 #4 Washer	3
22.	100-4-2 4-36 x 1/8 RHM Screw	2
23.	4045 S.B.A.\$ Cradle Ass'y	1
24.	100-4-5 4-36 x 5/16 RHM Screw	1
25.	4052 S.B.A.\$ Undersized Lever	1
26.	1108 S.B.A.\$ Rail	1

BACK VIEW

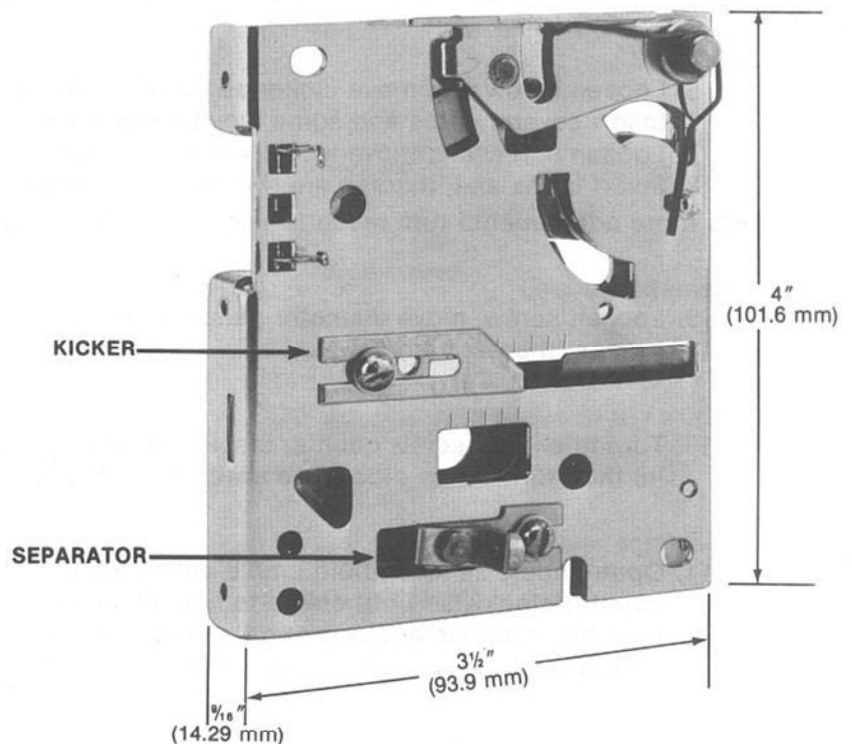

## FRONT VIEW

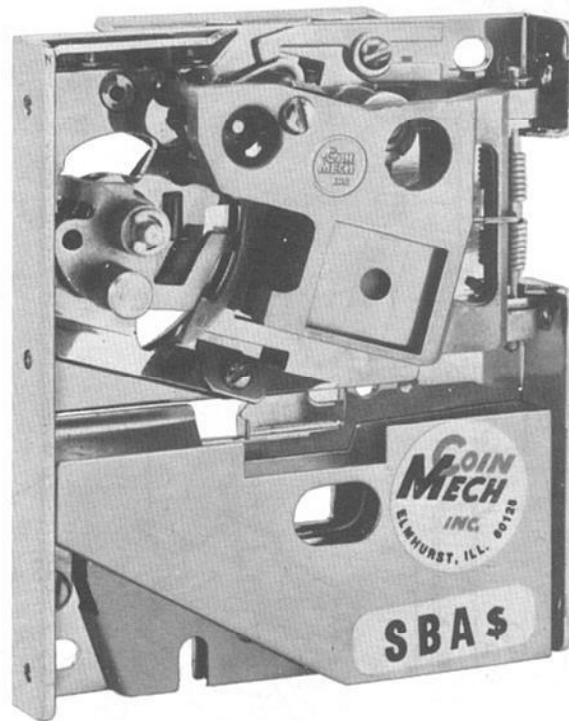

### S.B.A. \$ ADJUSTMENTS

All S.B.A.\$ mechs leave the factory adjusted for maximum performance. If, however, more critical adjustments are desired, or if unit has been disassembled for service, the following adjustment procedure is suggested.

Set the coin mech with the back of the unit facing you in the test position.

#### A. Separator Assembly

1. Loosen screw holding the separator ass'y and move as far to the right as it will go. Tighten screw.
2. Insert several coins, and note that some are returned by striking the separator.
3. Loosen screw and move separator a slight amount to the left. Tighten screw.
4. Insert coins again and, if some are still returned, repeat step #3 until all coins are accepted.

#### B. Kicker

5. Loosen screw and move kicker as far to the left as it will go. Tighten screw.
6. Insert several coins and some may be returned.
7. Loosen screw and move kicker a slight amount to the right. Tighten screw.
8. Insert coins and, if some are still returned, repeat step #7 to accept all coins.

For more adjustments turn mech to front view and proceed.

#### C. Diameter gauge

9. Loosen screw, move diameter gauge to left, insert coin and move gauge to right until coin passes, then tighten screw.

#### D. Magnet gate assembly

10. Turn thickness screw counter clockwise several turns or until coin hangs up (when dropped in) then turn screw clockwise until coin just passes, now turn 1/8 turn more.

#### E. Undersize lever spring

11. Open undersize lever, hold cradle with weight up. Loosen retainer screw and turn retainer counter clockwise until cradle is held by lever.
12. Now turn retainer clockwise until cradle is released to normal position and does not hang at bottom of undersize lever. Test several coins to avoid jamming.

## ANTI-CHEAT PENDULUM KIT NO. 5008

This security device has been developed and tested to achieve greater safety against "cheaters" as an optional part of the mech.

With proper setting between switch wire and pendulum, tests have proven virtually 100% effective.

Aside from "stringing" protection, the "pendulum" acts as a dampener and deflector for smaller coins, such as pennies to help by pass the switch wire.

### ANTI-CHEAT PENDULUM KIT NO. 5008

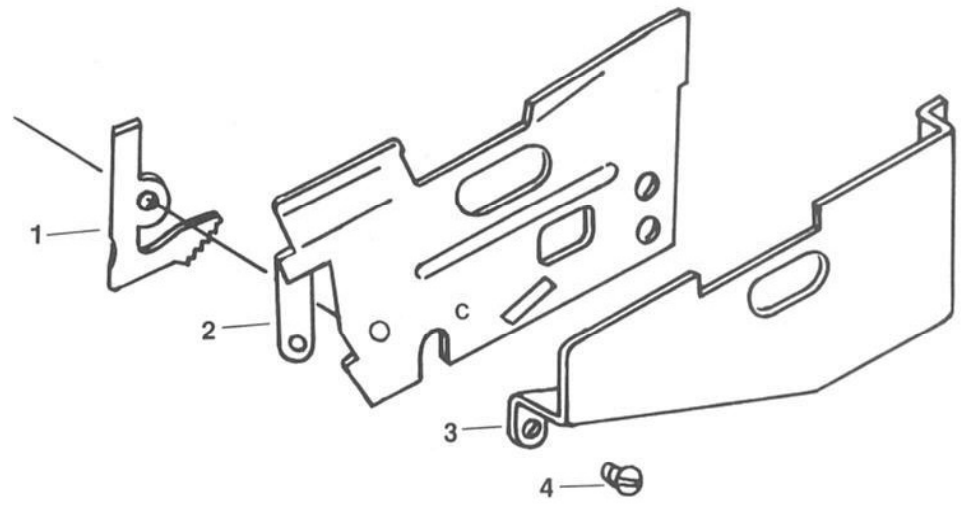

- 1. Part No. 1131 Pendulum
- 2. Part No. 4059-C Coverplate Ass'y.
- 3. Part No. 1004 Return Coverplate
- 4. Part No. 188-6-2 6-32 X 1/8 R.H.M.S.

- Step 1** Remove Return Coverplate (Upper) and (Lower) Coverplate.
- Step 2** Assemble Coverplate <sup>2</sup> and Pendulum 1. as shown above.
- Step 3** Check Pendulum action assuring free motion.
- Step 4** Check switch wire below Coin Mech for proper clearance, it should be approximately 3/4" minimum, below Pendulum before contacts are closed. Thus ensuring greater safety of mechanism.

## 50¢ ANTI-CHEAT PENDULUM KIT NO. 5010

This security device has been developed and tested to achieve greater safety against "cheaters" as an optional part of the mech.

With proper setting between switch wire and pendulum, tests have proven virtually 100% effective.

Aside from "stringing" protection, the "pendulum" acts as a dampener and deflector for smaller coins, such as pennies to help by pass the switch wire.

### 50¢ ANTI-CHEAT PENDULUM KIT NO. 5010

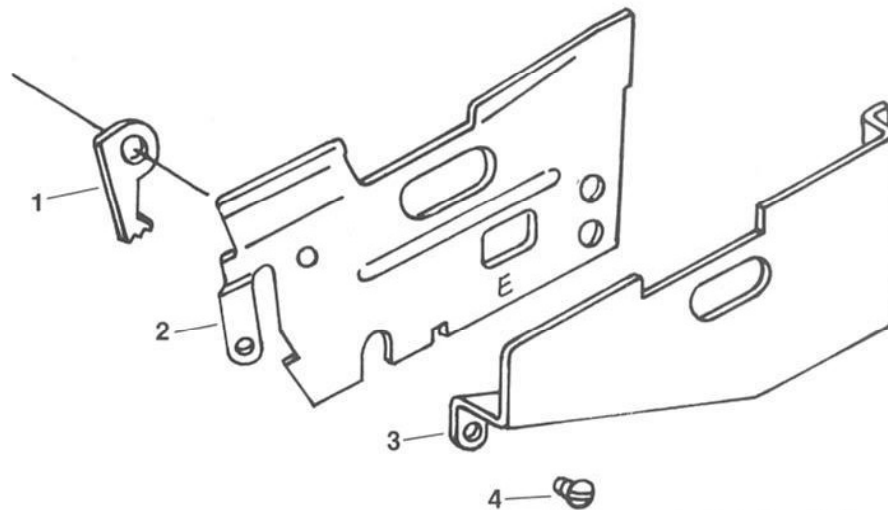

1. Part No. 1133 Pendulum
2. Part No. 4060-E Coverplate Ass'y.
3. Part No. 1004 Return Coverplate
4. Part No. 188-6-2 6-32 X 1/8 R.H.M.S.

**Step 1** Remove Return Coverplate (Upper) and (Lower) Coverplate.

**Step 2** Assemble Coverplate *f* and Pendulum 1. as shown above.

**Step 3** Check Pendulum action assuring free motion.

**Step 4** Check switch wire below Coin Mech for proper clearance, it should be approximately 3/4" minimum, below Pendulum before contacts are closed. Thus ensuring greater safety of mechanism.