

**SKEE-BALL, INC.**

121 Liberty Lane, Chalfont, PA 18914 • 215/997-8900

# INSTRUCTIONS FOR

## CIRCUS

## HI RISE

Skee-Ball • Skee Roll • Amusement Devices



TABLE OF CONTENTS

INSTALLATION INSTRUCTIONS..... 2  
    UNPACKING..... 2  
    ASSEMBLY..... 2  
    DESCRIPTION OF SWITCHES..... 2

FUNCTIONAL DESCRIPTION..... 3  
    GAME PLAY..... 3  
    TICKET DISPENSER..... 3  
        ELECTRICAL..... 3  
        MECHANICAL..... 4  
    LOADING OF TICKETS..... 4  
    TD PD BOARD..... 4  
    ROLLER TENSION SPRING..... 4  
    TICKET GUIDE SPRING..... 4  
    TICKET STOP ADJUSTMENT..... 5

TROUBLESHOOTING GUIDE..... 6  
    IMPROPER SCORING..... 6  
    NO SOUND..... 6  
    FAILS TO COIN UP..... 6  
    COUNTERS FAIL..... 6  
    LAMPS DO NOT LIGHT..... 6

WARRANTY..... 7

SCHEMATICS.....A-1  
    CPU, ROM, RAM, COUNTER.....A-2  
    I/O, SWITCH INPUTS.....A-3  
    SOUND, BALL RELEASE, FLASHER.....A-4  
    POWER SUPPLY.....A-5  
    DISPLAY.....A-6

## INSTALLATION INSTRUCTIONS

### A. UNPACKING CRATED GAME.

THE GAME COMES COMPLETELY ASSEMBLED. ALL YOU NEED TO DO IS INSTALL THE TICKETS(IF USED), PLUG GAME INTO A PROPERLY GROUNDED 3 CONDUCTOR OUTLET AND ITS READY FOR PLAY. IT IS SET UP TO PLAY ON 1 COIN AND DISPENSE 1 TICKET PER LEVEL. THESE SETTINGS CAN BE CHANGED VIA A DIP SWITCH, REFER TO YOUR MANUAL FOR OPTIONS.

### SETTING THE GAME OPTIONS VIA THE DIP SWITCH

NOTE! TURN OFF POWER BEFORE CHANGING SWITCH POSITION

1	2	# OF TICKETS PER LEVEL (GREEN THRU WINNER - 6)
OFF	OFF	0
OFF	ON	1
ON	OFF	2
ON	ON	3

3	4	# OF PLAYS PER COIN
OFF	ON	1 * SHOULD BE OFF FOR CHR 22 EPROM
ON	OFF	2 } NOT AVAILABL ~
ON	ON	3 } CHR 22

6	ATTRACT SOUND
OFF	NO SOUND IN ATTRACT MODE
ON	SOUND DURING ATTRACT MODE

7	8	# OF COINS
OFF	OFF	0
OFF	ON	1
ON	OFF	2
ON	ON	3

## GAME PLAY

AFTER THE PROPER NUMBER OF COINS ARE INSERTED THE PUCK WILL BE RELEASED AND READY TO STRIKE.

### GAME SEQUENCE:

- A. INSERT COIN
- B. SOLENOID ENERGIZES
- C. PUCK IS RELEASED
- D. ALL TARGET LIGHTS SHOULD BE OUT
- H. AFTER THE TARGET IS STRUCK AND THE PUCK MAKES IT BY THE BLUE SENSOR THE FOLLOWING EVENTS OCCUR:
  1. THE SOLENOID DEENERGIZES
  1. THE LAMPS BEGIN TO LIGHT AND REMAIN LIT
  2. THE AUDIO CHANGES PITCH ON THE WAY UP & DOWN
  3. TICKETS ARE DISPENSED AT THE END OF THE GAME

## TICKET DISPENSER

### 1. BASIC ELECTRONIC OPERATION OF TICKET DISPENSER

WHEN THE CONTROL UNIT CALLS FOR A TICKET TO BE ISSUED, THE MOTOR IN THE DISPENSER IS TURNED ON. WHEN A TICKET IS DISPENSED, THE OPTO BEAM BREAKER SENSES A NOTCH IN THE TICKET AND SENDS BACK A SIGNAL TO THE CONTROL UNIT. AT THIS TIME THE TICKET COUNTER IS INCREMENTED. IF NO MORE TICKETS ARE CALLED FOR THE MOTOR IS TURNED OFF.

### 2. BASIC MECHANICAL OPERATION OF THE TICKET DISPENSER

TICKETS ARE MOVED THROUGH THE TICKET CHUTE BY MEANS OF A POWER DRIVEN ROLLER WHICH IS SPRING LOADED AGAINST AN IDLER ROLLER. THE POWER DRIVEN ROLLER HAS TWO NEOPRENE O RINGS INSTALLED, AND UNDER NORMAL OPERATING CONDITIONS ARE THE ONLY CONTACT WITH THE TICKETS.

pa

THE POWER DRIVEN ROLLER IS MOUNTED ON THE OUTPUT SHAFT OF THE MOTOR GEAR TRAIN ASSEMBLY. THE MOTOR ASSEMBLY IS MOUNTED TO THE PIVOT BRACKET ASSEMBLY IN THE TWO OILITE BEARINGS. THE MOTOR ASSEMBLY HAS A LIMITED FREE SWING, LIMITED BY A SINGLE PIN ENGAGED IN THE BRAKE SPRAG. THE BRAKE SPRAG ENGAGES THE ROLLER AS AN ANTI THEFT DEVICE. WITH THE FREE SWING OF THE MOTOR ASSEMBLY, THE DIRECTION OF TORQUE, WHEN THE ELECTRIC POWER IS APPLIED, IS IN A DIRECTION SO AS TO RELEASE THE BRAKE SPRAG. WHEN AN ATTEMPT IS MADE TO PULL TICKETS FROM THE MACHINE WITH THE POWER OFF, THE TORQUE IS REVERSED AND THE BRAKE SPRAG IS ENGAGED. ALSO, THE PULLING OF TICKETS WILL CAUSE THE PIVOT BRACKET ASSEMBLY TO APPLY A PRESSURE TO THE POWER DRIVEN ROLLER AGAINST THE TICKET AND IDLER ROLLER GREATER THAN THE PRE-SET SPRING LOAD. THIS WILL CAUSE THE O RINGS TO DEPRESS AND THE COURSE KNURLED SURFACE OF THE ROLLER WILL THEN GRIP THE TICKETS. ONE OUNCE OF PULL WILL APPLY 20 LBS. OF PRESSURE ON THE ROLLERS.

### 3. LOADING OF TICKETS

TICKETS ARE ENTERED IN THE REAR OF TICKET CHUTE AND PUSHED FORWARD. THE POWER DRIVEN ROLLER WILL BE SPRING LOADED AGAINST THE IDLER ROLLER AND TICKETS WILL NOT PASS UNTIL THE ROLLERS ARE CLEAR OF EACH OTHER. THIS IS ACCOMPLISHED BY USE OF THUMB AND INDEX FINGER, ONE PLACED ON THE BLOCK TO WHICH THE SPRING IS ATTACHED, THE OTHER ON THE PIVOT BRACKET ASSEMBLY, THEN SQUEEZE. PUSH THE TICKETS THROUGH UNTIL YOU SEE THE EDGE OF THE TICKET. MACHINE IS NOW READY TO OPERATE.

### 4. TICKET DISPENSER CONTROLLER BOARD

ATTACHED TO THE TICKET MACHINE IS A TRANSISTOR MOTOR CONTROLLER WHICH PROVIDES DYNAMIC BRAKING TO ENSURE ACCURATE AND REPEATABLE TICKET STOPPING AFTER ISSUING ANY NUMBER OF TICKETS. INCLUDED AS PART OF THE CONTROLLER IS TICKET SENSING BY MEANS OF AN OPTO BEAM BREAKER SENSOR. ALSO INCLUDED IN SIGNAL CONDITIONING WHICH PROVIDES HIGH ELECTRICAL NOISE IMMUNITY. THE OUTPUT OF THE TICKET SENSING CIRCUITRY IS THE EQUIVALENT TO A SINGLE POLE DOUBLE THROW SWITCH.

### 5. ROLLER TENSION SPRING

THE ROLLER TENSION SPRING KEEPS CONSTANT TENSION ON THE TICKETS, WHICH INSURES PROPER DELIVERY AND PREVENTS TICKETS FROM BEING PULLED THROUGH WHEN THE DISPENSER IS IDLE. TO INCREASE TENSION, LOOSEN SCREW AND MOVE SPRING FORWARD. TENSION IS ADJUSTED CORRECTLY WHEN THE TICKETS CANNOT BE PULLED FROM THE DISPENSER.

### 6. TICKET GUIDE SPRING

THE TICKET GUIDE SPRING INSURES THAT THE NOTCHES IN THE TICKETS PASS THROUGH THE OPTO BEAM BREAKER SENSOR. TO INCREASE TENSION, LOOSEN SCREW AND MOVE OUTER SPRING UP. THIS CHANGES THE TENSION ON THE INNER SPRING. TICKETS SHOULD BE SNUG BETWEEN SPRING AND SIDE PLATE BUT NOT DEFORMED BY EXCESS TENSION. THIS SPRING IS ADJUSTED AT THE FACTORY FOR 1-3/16" WIDE TICKETS.

## 7. TICKET STOP ADJUSTMENT

THE TICKET STOP ADJUSTMENT ALLOWS POSITIONING OF TICKETS WHILE MACHINE IS OFF. THE TICKET SHOULD PROTRUDE THROUGH SLOT APPROXIMATELY 1/16". THE TICKET DISPENSER PC BOARD IS MOUNTED WITH TWO SCREWS AND TWO SLOTTED HOLES. LOOSENING THE SCREWS AND MOVING THE BOARD FORWARD WILL ALLOW THE TICKETS TO STOP FARTHER OUT BEYOND THE EDGE OF THE SLOT.

TICKETS ARE AVAILABLE THROUGH: NATIONAL TICKET CO IN SHAMOKIN, PA (717) 648-6803. WE HAVE FOUND THESE TICKETS TO BE OF THE BEST QUALITY FOR USE IN SKEE BALL REDEMPTIVE GAMES.

## TROUBLESHOOTING GUIDE

CAUTION: HIGH VOLTAGE IS PRESENT IN SOME AREAS OF THE GAME (POWER SUPPLY, FAN SOLENOID, ETC.) UNPLUG LINE CORD BEFORE PERFORMING ANY TROUBLE SHOOTING.

### A. IMPROPER SCORING

DEFECTIVE SENSOR OR POSSIBLY A BAD INPUT ON THE CONTROLLER.

### C. NO SOUND

IF NO MUSIC OCCURS DURING THE PLAY OF A GAME, FIRST CHECK THAT VOLUME CONTROL IS TURNED UP. THEN CHECK THAT THE CABLES ARE OK & MAKE SURE THAT THE SPEAKER IS NOT DAMAGED. REPLACE SPEAKER IF NECESSARY. THEN REPLACE THE SOUND BOARD. IF THIS IS NOT THE PROBLEM, THEN RETURN THE UNIT AS PER INSTRUCTIONS.

### D. COIN INSERTION DOES NOT RELEASE PUCK

AFTER INSERTING COIN THE SOLENOID SHOULD ENERGIZE. IF THIS DOES NOT OCCUR, CHECK THE COIN MECH SWITCH FOR PROPER ACTION. THE ACTUATING ARM MAY NEED ADJUSTING OR THE ENTIRE SWITCH MAY NEED REPLACING.

### E. COUNTERS DO NOT WORK

CHECK THE CABLE CONNECTION FROM THE COUNTERS TO THE LOGIC BOARD. REPLACE THE COUNTER WITH A GOOD COUNTER. IF IT STILL DOES NOT WORK, THEN REPLACE THE LOGIC BOARD. RETURN THE UNIT FOR REPAIR AS INSTRUCTED IN THIS TEXT.

### F. DISPLAY LAMP DOES NOT LIGHT

IF ANY LAMP DOES NOT LIGHT, FIRST CHECK TO INSURE THAT THE LAMP IS PROPERLY SEATED IN THE SOCKET. DO NOT REPLACE LAMPS WHILE POWER IS ON. USE ONLY THE PROPER REPLACEMENT BULBS. REMOVE BULB BY THE GLASS PORTION OF THE BULB ONLY. DO NOT PLACE ANY TOOL IN THE SOCKET WHILE THE POWER IS ON. THIS COULD DAMAGE EXPENSIVE CIRCUITRY.

IF THE LAMP STILL DOES NOT LIGHT, THEN TRY REPLACING THE UCN5833A. THIS IC CONTROLS ALL THE FUNCTIONS ON THE TRIAC BD. ALWAYS POWER DOWN TO REPLACE LAMPS AND IC'S. MAKE ABSOLUTELY SURE THAT THE NEW IC'S ARE INSTALLED PROPERLY. IDENTIFY THE DIRECTION IN WHICH THE NEW IC IS TO BE INSTALLED BEFORE THE SUSPECTED BAD IC IS REMOVED.

NOTE!! PLACE TICKETS IN THE DISPENSER SO THAT THE NOTCH IS IN LINE WITH PHOTO DETECTOR BEFORE DEPRESSING THE KNOCK OFF SWITCH.

## WARRANTY REPAIRS

THE WARRANTY ON THE ELECTRONIC UNITS IS FOR A PERIOD OF ONE YEAR, INCLUDING SHIPPING ONE WAY. THE WARRANTY WILL BE VOID IF THE UNIT IS NOT INSTALLED PROPERLY, OR IF IT HAS BEEN TAMPERED WITH. THE RECEPTICLES FOR 3 PRONG PLUGS MUST BE USED, AS THE ELECTRONIC UNITS CALL FOR A POLARIZED CIRCUIT. WHEN RETURNING A UNIT FOR REPAIR, UNDER WARRANTY OR NOT, YOU MUST FIRST CALL AND OBTAIN AN AUTHORIZATION NUMBER. THIS NUMBER MUST BE WRITTEN ON THE OUTSIDE OF THE BOX YOU RETURN YOUR UNIT IN. IF YOU FAIL TO DO THIS, YOUR UNIT WILL BE REFUSED AND SENT BACK TO YOU. AN EXCHANGE PROGRAM IS OFFERED FOR THE FIRST SIX MONTHS YOU HAVE YOUR ALLEY. THIS ALSO MUST BE AUTHORIZED, FOR WE WILL SEND YOU A NEW BOARD IN EXCHANGE FOR THE RETURN OF YOUR OLD BOARD. AFTER SIX MONTHS, YOU MUST SEND YOUR BOARD IN FOR REPAIR. BEFORE CALLING SKEE BALL (215-997-8900), FIRST TRY AND LOCATE THE FAULTY PART, BUT DO NOT ATTEMPT REPAIR. MAKE SURE THAT YOU INCLUDE A NOTE WITH YOUR UNIT DESCRIBING THE PROBLEM IN YOUR OWN WORDS, AND BE SURE TO INCLUDE YOUR NAME AND PHONE NUMBER WHERE YOU CAN BE REACHED.



NOTES #  
1. OPTIONAL SNUBBER CKT

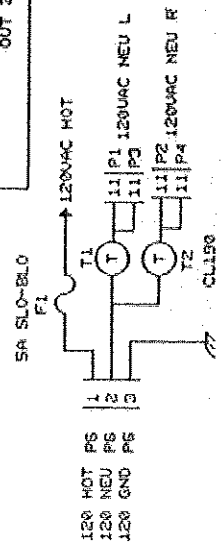
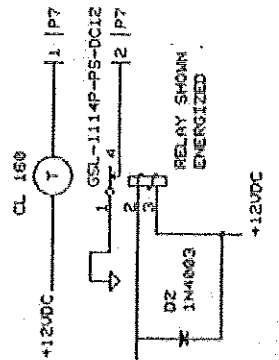
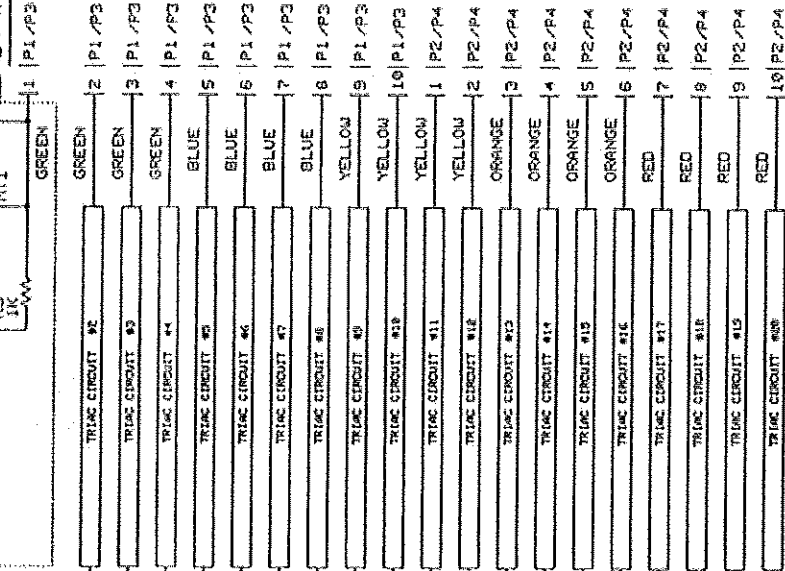
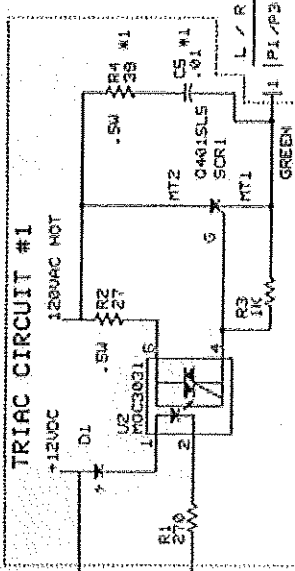

SKEE-BALL INC.		
CIRCUS HI-RISE		
D REV	SBI-1	TRIAC LAMP DRIVER BO.
DATE	7/24/93	OK CHR.P05 SHEET 1 OF 1

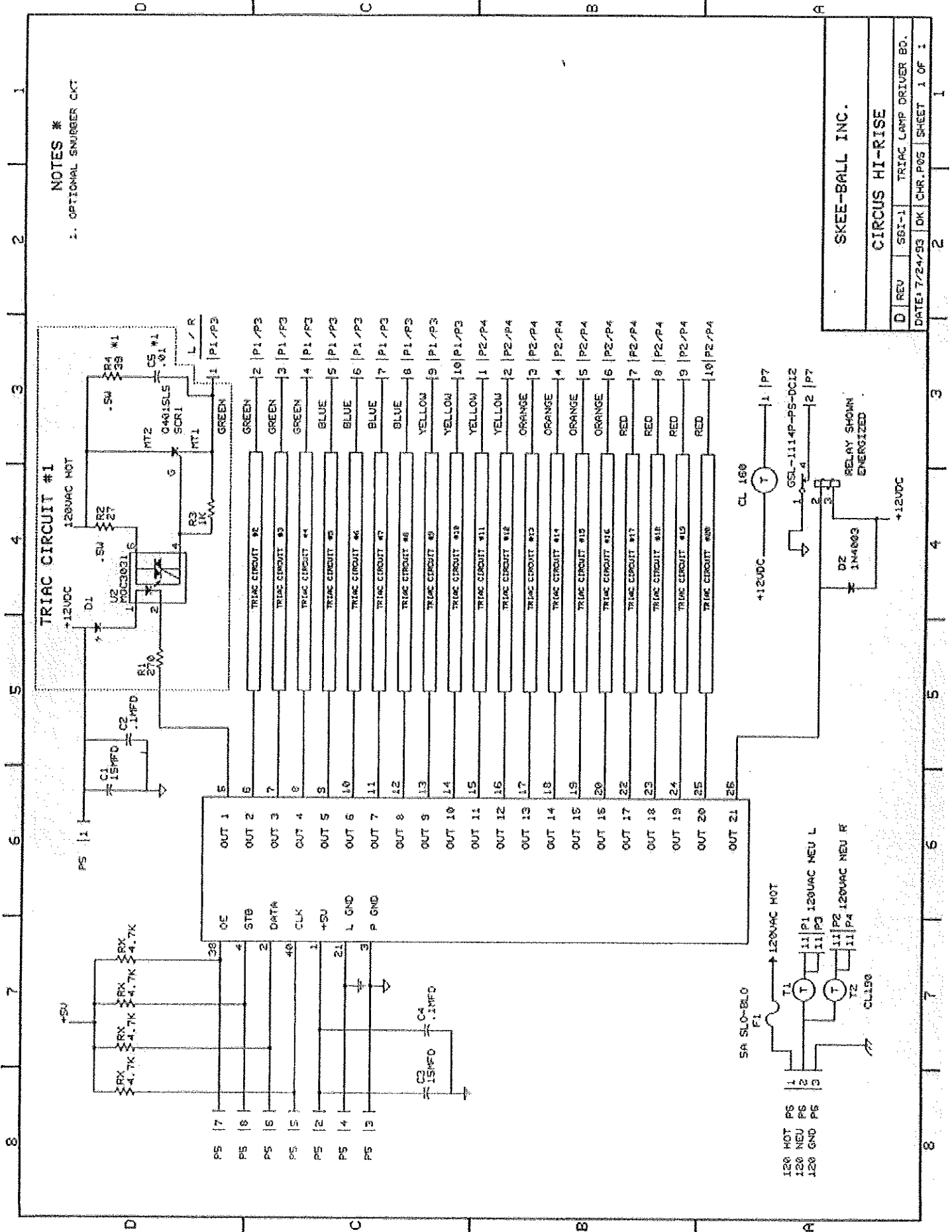

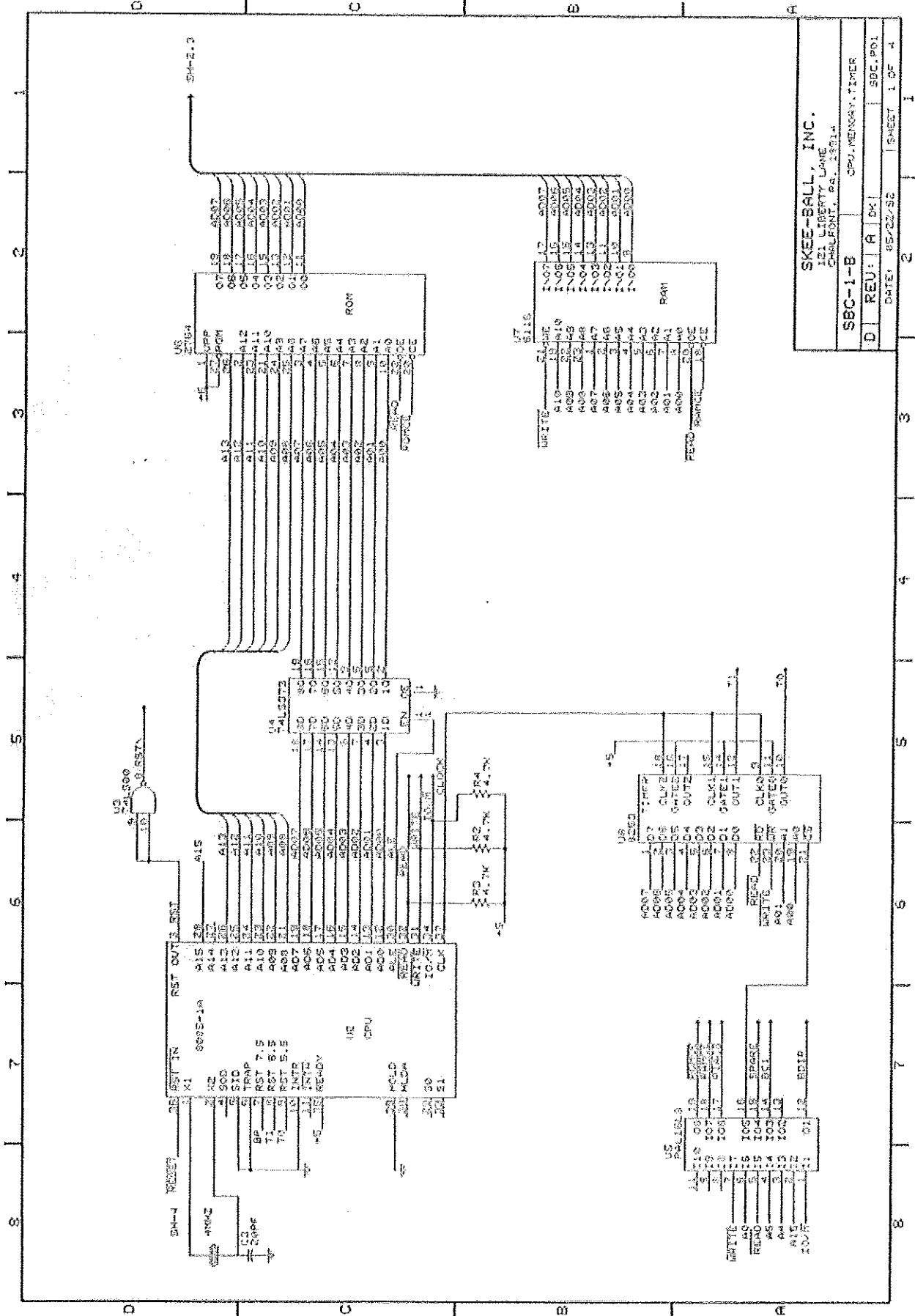

**SKEE-BALL, INC.**  
 121 LIBERTY LANE  
 CHARLTON, P.R. 03514

**SBC-1-B** CPU MEMORY TIMER

0 REV: A BK1 SBC.POL  
 DATE: 05/22/88 SHEET 1 OF 4

US 2784  
 15  
 07 19 A007  
 08 18 A008  
 09 17 A009  
 0A 16 A00A  
 0B 15 A00B  
 0C 14 A00C  
 0D 13 A00D  
 0E 12 A00E  
 0F 11 A00F

ROM

V7 5116  
 WRITE  
 A10 A19  
 A08 A07  
 A06 A05  
 A04 A03  
 A02 A01  
 A00

RAM

US 2784  
 15  
 07 19 A007  
 08 18 A008  
 09 17 A009  
 0A 16 A00A  
 0B 15 A00B  
 0C 14 A00C  
 0D 13 A00D  
 0E 12 A00E  
 0F 11 A00F

CPU

US 2784  
 15  
 07 19 A007  
 08 18 A008  
 09 17 A009  
 0A 16 A00A  
 0B 15 A00B  
 0C 14 A00C  
 0D 13 A00D  
 0E 12 A00E  
 0F 11 A00F

CPU

US 2784  
 15  
 07 19 A007  
 08 18 A008  
 09 17 A009  
 0A 16 A00A  
 0B 15 A00B  
 0C 14 A00C  
 0D 13 A00D  
 0E 12 A00E  
 0F 11 A00F

CPU

US 2784  
 15  
 07 19 A007  
 08 18 A008  
 09 17 A009  
 0A 16 A00A  
 0B 15 A00B  
 0C 14 A00C  
 0D 13 A00D  
 0E 12 A00E  
 0F 11 A00F

CPU

US 2784  
 15  
 07 19 A007  
 08 18 A008  
 09 17 A009  
 0A 16 A00A  
 0B 15 A00B  
 0C 14 A00C  
 0D 13 A00D  
 0E 12 A00E  
 0F 11 A00F

CPU

\*1. R9 THRU R13 HAVE BEEN CHANGED TO 2.2K

NOTES

SKEE-BALL, INC.  
121 LIBERTY LANE  
CHRLFONT, PA. 18914

SBC-1-D SWITCH INPUTS, I/O

REU-0 DK CHR CHR.P02

DATE: 09/27/93 SHEET 2 OF 4

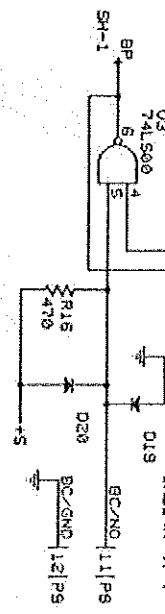
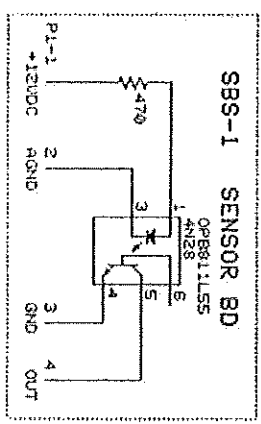
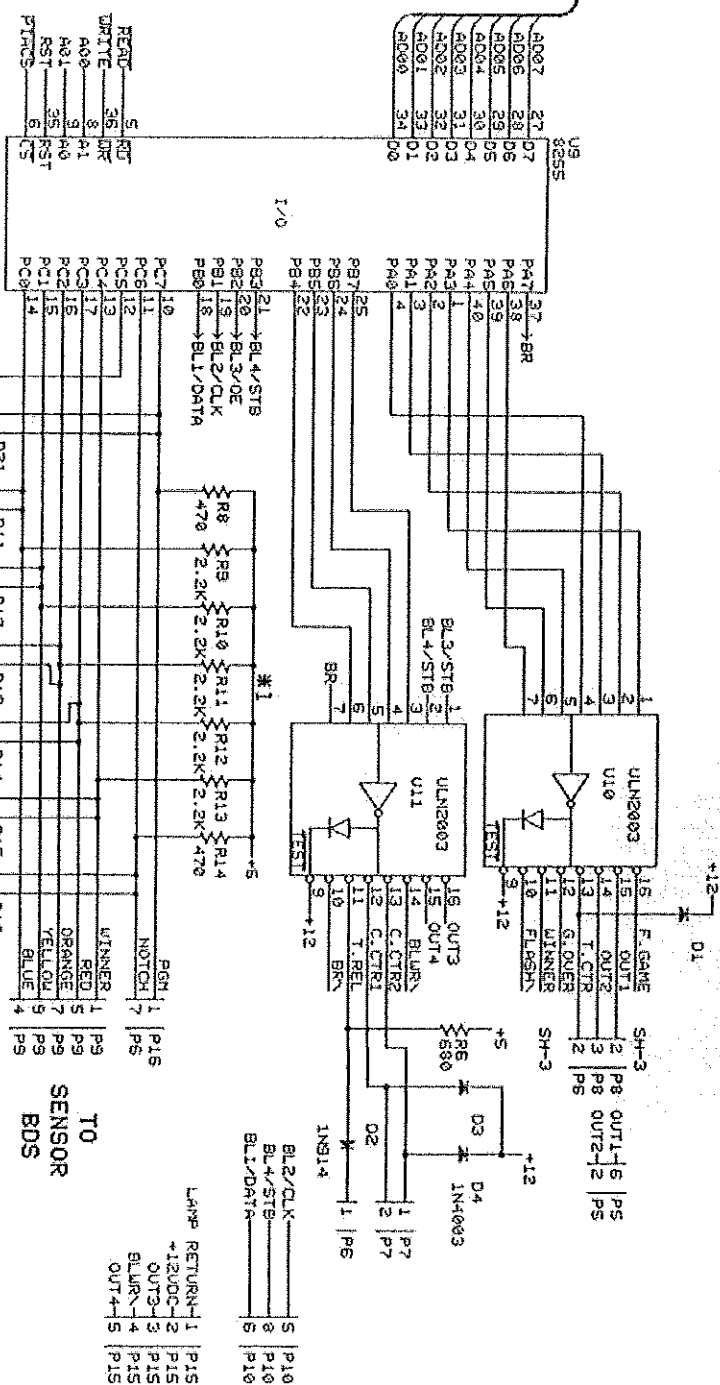

8 7 6 5 4 3 2 1

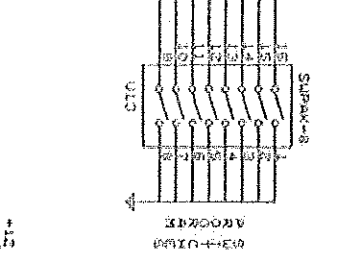
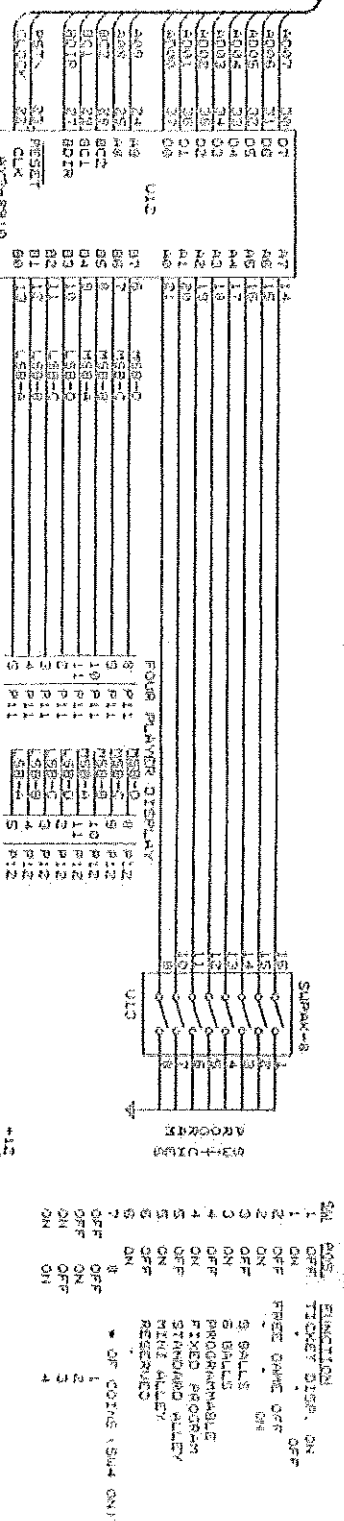

SW	POS	FUNCTION
1	OFF	TICKET DISP. ON
1	ON	FREE CHNG OFF
2	OFF	FREE CHNG OFF
2	ON	FREE CHNG ON
3	OFF	5 BALLS
3	ON	5 BALLS
4	OFF	PROGRAMMABLE
4	ON	FIXED PROGRAM
5	OFF	STANDARD RELAY
5	ON	WING ALLEY
6	OFF	RESERVED
6	ON	RESERVED
7	OFF	OF COINS (S4 ON)
7	ON	OF COINS (S4 ON)
8	OFF	OF COINS (S4 ON)
8	ON	OF COINS (S4 ON)
9	OFF	OF COINS (S4 ON)
9	ON	OF COINS (S4 ON)
10	OFF	OF COINS (S4 ON)
10	ON	OF COINS (S4 ON)

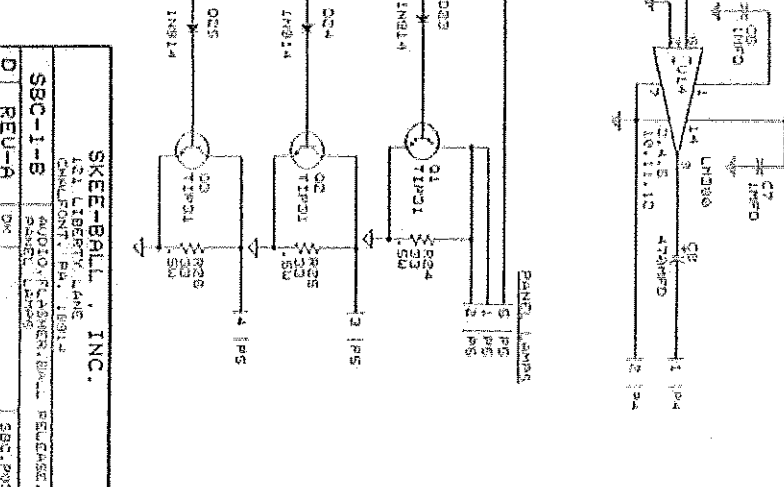
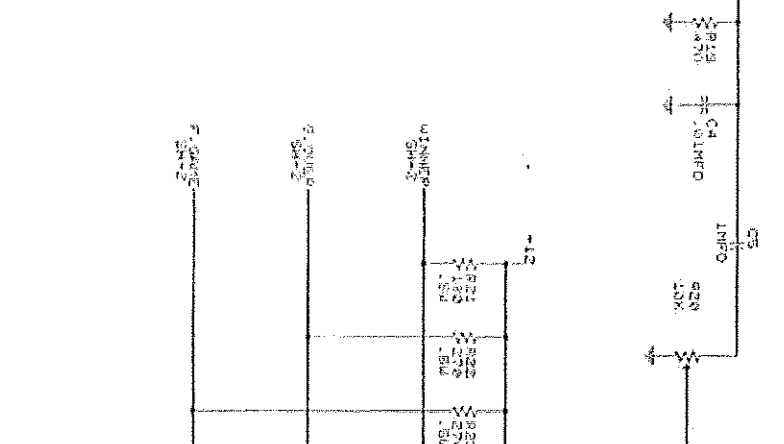
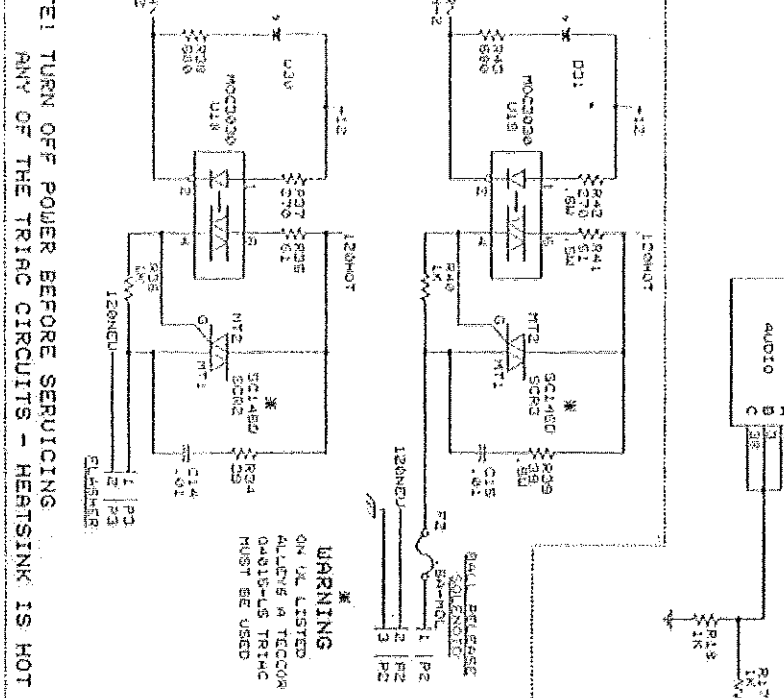

NOTE! TURN OFF POWER BEFORE SERVICING ANY OF THE TRIAC CIRCUITS - HEATSINK IS HOT

**WARNING**  
ON V.L. LISTED ALLEYS A TECORA 04015-US TRIAC MUST BE USED

**SKEE-BALL, INC.**  
122 LINDEN BLVD  
CONCORD, N.H. 03301  
SBC-1-B AUDIO FLASHER BALL RELEASE  
D1 REU-A Dk SBC-PAD  
DATE: 08/22/82 SHEET 3 OF 4

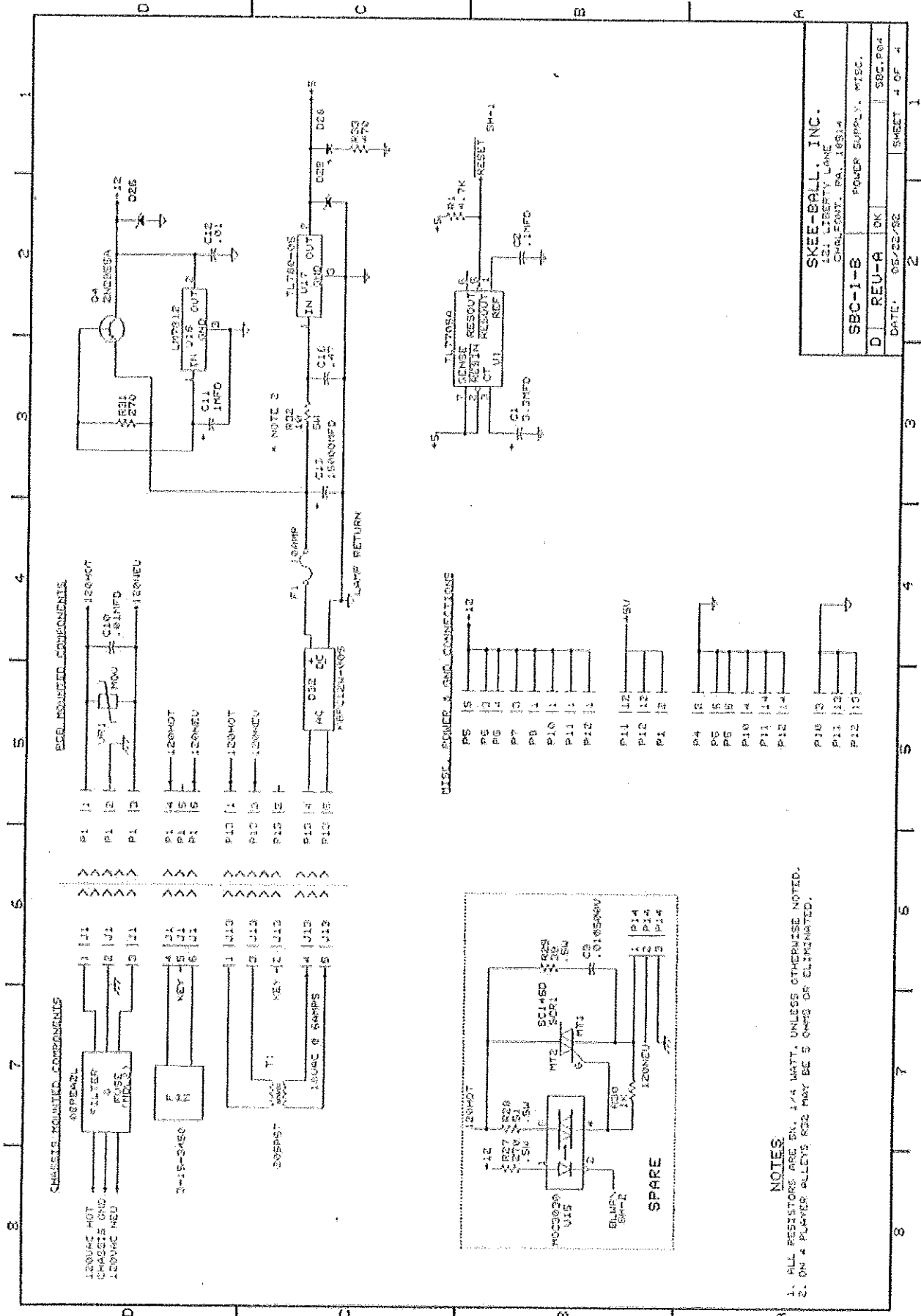

SKEE-BALL, INC.			
131 LIBERTY LANE			
CHALFOUNT, PA. 19314			
SBC-1-B	POWER SUPPLY - MISC.		
D	REU-A	DK	SBC.P04
DATE: 08-22-80		SHEET 4 OF 4	

WIRE POWER AND CONNECTIONS

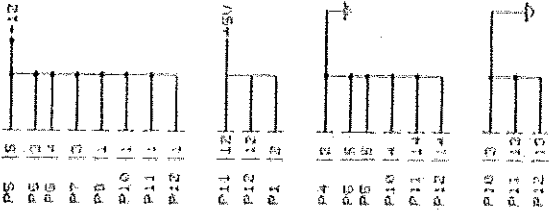

- NOTES:
1. ALL RESISTORS ARE EX. 1/4 WATT, UNLESS OTHERWISE NOTED.
  2. ON 4 PLAYER ALLEYS S22 MAY BE 5 OHMS OR ELIMINATED.

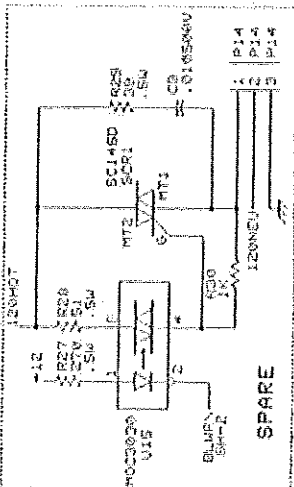

PCB MOUNTED COMPONENTS

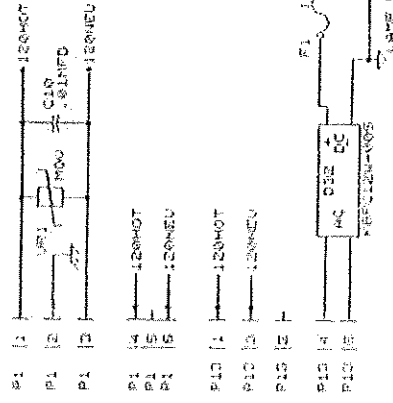

CHASSIS MOUNTED COMPONENTS

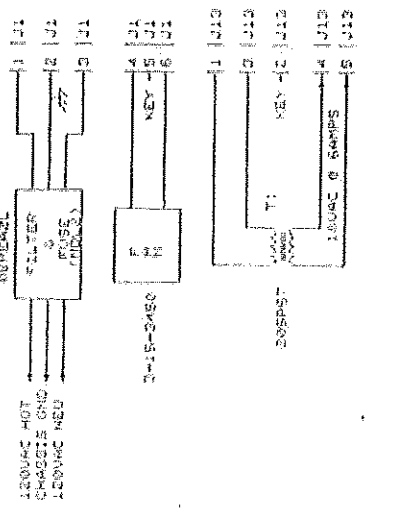

**SENSOR BDS.**

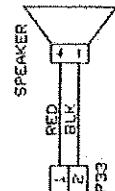
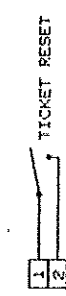
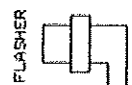
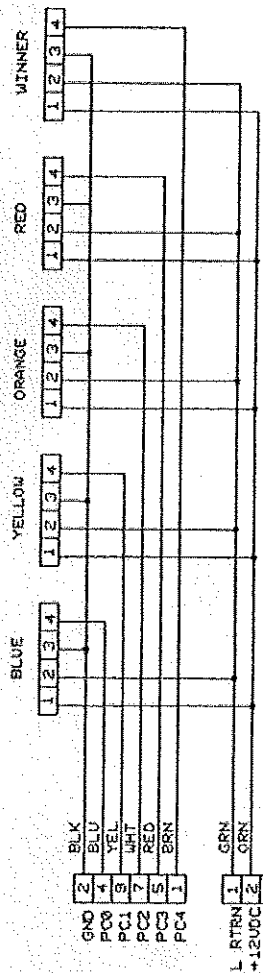

SBI-1	
20	20
19	19
18	18
17	17
16	16
15	15
14	14
13	13
12	12
11	11
10	10
9	9
8	8
7	7
6	6
5	5
4	4
3	3
2	2
1	1



**SKEE-BALL, INC.**  
 12 LIBERTY LANE  
 CHALFONT, PA. 19314

**CABLES**      **CHRCAB.P01**

**D REV-1**      **CIRCUS HI-RISE**

DATE: 9/28/93      SHEET 1 OF 1