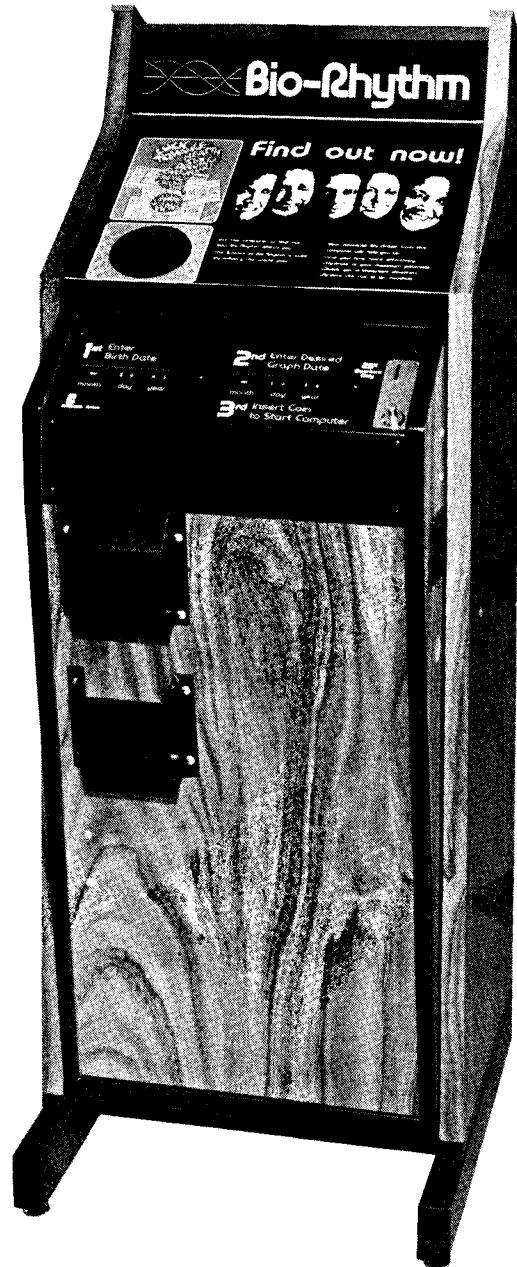


# Bio-Rhythm III

OWNERS MANUAL

MODEL F-8



Compunetic Devices

C O N T E N T S

EXPLANATION OF BIO-RHYTHM THEORY .....	1
EXPLANATION OF BIO-RHYTHM COMPUTER .....	2
INSTALLATION OF BIO-RHYTHM CARDS .....	3
BIO-RHYTHM III INK PEN INSTALLATION .....	4
BIO-RHYTHM III INK TAPE CARTRIDGE INSTALLATION .....	5
PREVENTIVE MAINTAINANCE .....	6
CUT-OFF BLADE ADJUSTMENT .....	7
PHOTOSENSOR REPLACEMENT .....	10
BIO-RHYTHM PHOTSENSOR CHECK .....	12
BIO-RHYTHM GENERAL TROUBLE SHOOTING GUIDE .....	13, 14
DATE ERROR EXAMPLES .....	16
PRINTED CIRCUIT PARTS LIST .....	19, 20, 21
CABINET PARTS LIST .....	21, 22
CHASSIS PARTS LIST .....	22, 23, 24
CABLE PARTS LIST .....	24
CIRCUIT BOARD REPLACEMENT .....	34

----- FIGURE LIST -----

FIGURE 1 - P.C. LAYOUT - COMPUTER BOARD .....	17, 18
FIGURE 2 - A/C CABINET WIRING .....	8
FIGURE 2 - POWER DISTRIBUTION BOARD LAYOUT .....	8
FIGURE 3 - LOGIC SCHEMATIC .....	35
FIGURE 4 - P.C. LAYOUT - DATE SWITCH BOARD .....	11
FIGURE 5 - CABINET PARTS .....	29
FIGURE 6 - HARNESS LAYOUT .....	9
FIGURE 7 - CHASSIS PARTS .....	32
FIGURE 8 - CHASSIS PARTS .....	28
FIGURE 9 - CHASSIS PARTS .....	25
FIGURE 10 - CHASSIS PARTS .....	33
FIGURE 11 - CHASSIS PARTS .....	27
FIGURE 12 - CHASSIS PARTS .....	26
FIGURE 13 - CABINET PARTS .....	30
FIGURE 14 - CABINET PARTS .....	31

FOR SPARE PARTS, SERVICE, TECHNICAL INFORMATION PLEASE CONTACT:

COMPUNETIC DEVICES INC.  
21121 Osborne St.  
Canoga Park, Ca. 90304  
(213) 341-2397

## EXPLANATION OF BIO-RHYTHM THEORY

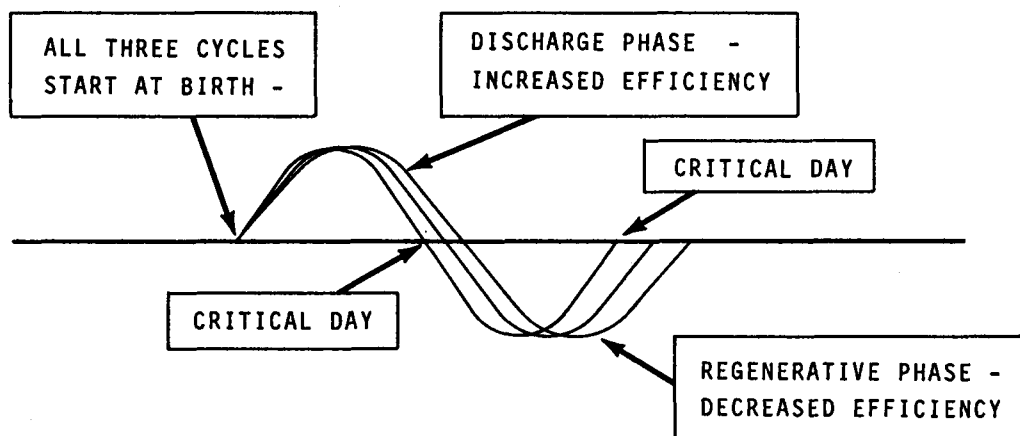
BIO-RHYTHM is a theory of apparent relationships between the emotional, physical, and intellectual aspects of the state of being. The relationships and duration were discovered empirically on a statistical basis.

PHYSICAL - 23 Day Period

EMOTIONAL - 28 Day Period

INTELLECTUAL - 33 Day Period

The highs and lows on the graph are not as significant as the day on which each cycle passes through zero. This day is called the "Critical Day". On a Critical Day, the Biological clocks are in a state of change. A person is most likely to make a mistake or have an accident on this day. Also, the three possible critical points are additive. A triple critical day is more dangerous than a single critical day.



## EXPLANATION OF THE BIO-COMPUTER

THE BIO-COMPUTER LOCATES THE TEN ATTRIBUTE PLOTS BY CALCULATING EXACTLY WHERE EACH OF THE THREE BIO-CYCLES ARE ENTERED FOR THE DAY, AND THEN MULTIPLIES THESE THREE NUMBERS BY THREE CONSTANTS FOR EACH ATTRIBUTE. THE ADDITIVE TOTAL NUMBER REPRESENTS THE ATTRIBUTE PLOT HEIGHT.

### - - - - - SEQUENCE OF EVENTS - - - - -

1. After power is applied the computer is waiting for a coin.
2. When a coin is recognized, the following sequence is started:
  - a. The dates are entered from the switches.
  - b. The plot heights are calculated and stored.
  - c. The photocell is adjusted.
  - d. The card starts moving.
3. As each timing mark on the card is recognized, a pen plot is started, and one or two numbers are printed.
4. After ten plots have been produced, the computer is waiting for the long black mark. At the end of the long black mark, the card is cut off and the computer waits for another coin.
5. When a card is started in the center, and less than ten plots are made, the computer will recognize the error and cut that card off, and then print a good card.

## INSTALLATION OF BIO-RHYTHM CARDS

1. Fold the axle shaft locks back and remove the axle, wood core and side plates.
2. Install the axle shaft, wood core and side plates into the roll of tickets.
3. Place the card reel assembly into the door and lock the shaft in place. Be sure the roll turns freely without any binding.
4. Straighten out the front edge of the card ( it may be helpful to cut it at a 45° angle ) and feed it through the card guides, and through the cut-off blade.
5. Apply power by pulling out the button on the interlock switch.
6. Drop a coin through the coin slot, and the machine will pull the cards through and cut-off. After a short pause it will print a card and stop.
7. Close the cabinet, being careful not to tear the cards on the coin chute.
8. Drop in another coin and check the card for correct dates and plot heights.
9. NOTE: there are 2000 cards in a roll.  
It is recommended that a new pen, and a new cartridge be installed each time a roll of cards is installed.

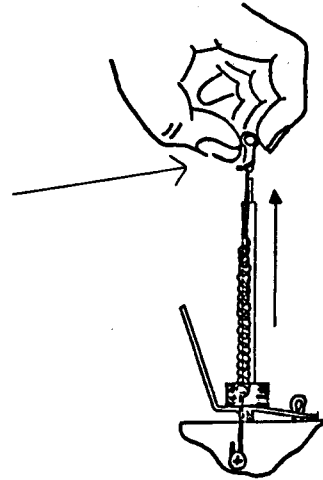
Cards are available in a balanced package consisting of the following:

5 rolls	-	CARDS
5 each	-	PENS ( modified )
5 each	-	CARTRIDGES ( modified )

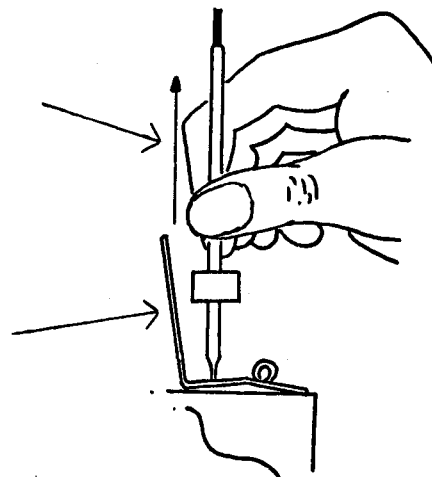
## BIO-RHYTHM III INK PEN INSTALLATION

---

1. The pen can be removed simply by lifting the spring retainer off the top of the pen.

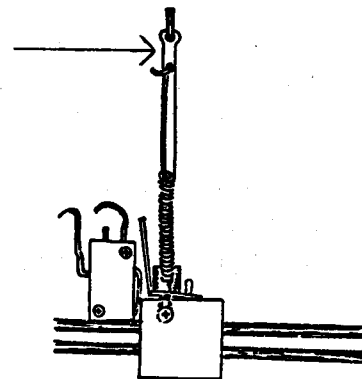


2. Lift pen out of pen block and "L" bracket.



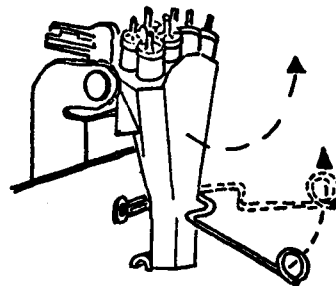
3. When installing a new pen be sure to place the pen through the pen lifting "L" bracket.

4. CAUTION: Eyelet must be used on end of pen. DO NOT insert the spring wire into the vent hole of the pen, this will prevent the flow of ink.

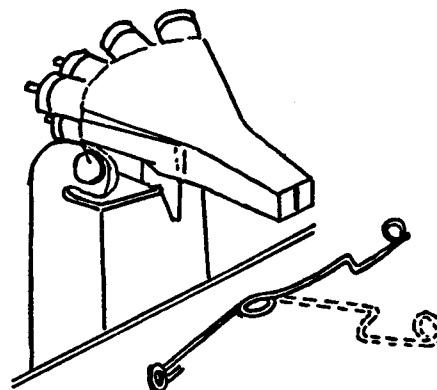


# BIO-RHYTHM III INK TAPE CARTRIDGE INSTALLATION

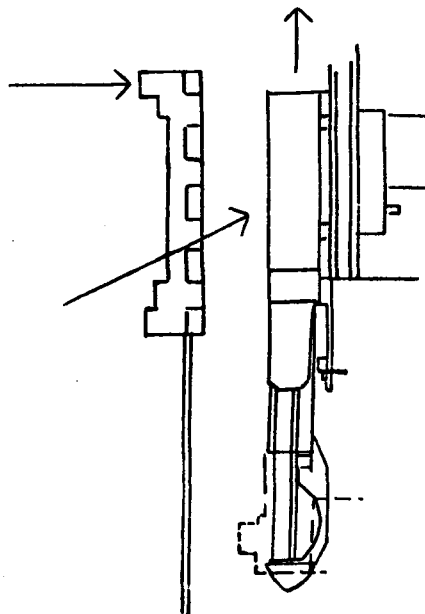
1. Release the printhead holding spring



2. Tilt the printhead out of the way.



3. Release tape cartridge by swinging hinged holder up.



4. Pull ink tape cartridge out of chassis towards the rear.

5. To install, reverse Steps 1 - 4.

6. When installing a new cartridge be sure gears are engaged and hinged holder is locked down in place.

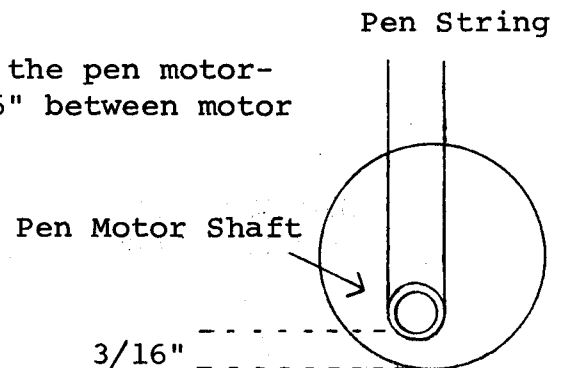
7. Be sure to lower printing head and lock into place with holding spring, after cartridge is installed.

## BIO-RHYTHM III PREVENTIVE MAINTAINANCE

---

AFTER EACH ROLL OF 2000 CARDS HAS BEEN DISPENSED, THE FOLLOWING ITEMS SHOULD BE CHECKED BY THE SERVICEMAN, TO MAINTAIN RELIABLE OPERATION OF THE BIO-RHYTHM III.

1. Insert at least ten (10) different quarters into the coin slot to insure that the coin mechanism works properly, and that foreign objects are not present in the coin chutes.
2. Check the operation of the coin switch trip wire. Coins should pass freely through the chute and the trip wire should return easily.
3. Inspect the condition of the pen string (see Figure 11, Item #86). The string should be running over all three pulleys. Enter a coin and check to see that all three pulleys turn smoothly.
4. Check the running clearance of the pen motor - it should not be less than  $3/16$ " between motor shaft and chassis hole.
5. The chart motor mounting screws (see Figure 7, Item #160) should be  $1/4$  turn loose, so that alignment with the feed roller will be maintained. Also see that the coupling is tight on the shaft.
6. Inspect the pen stop switch (see Figure 9, Item #62), it should operate freely and should be firmly mounted.
7. Check the cut-off blade adjustment. (See the following page for details)
8. Be sure that the roll of cards does NOT bind.
9. Check the condition of the pinch assembly bail roll, it should turn freely.





## BIO-RHYTHM III

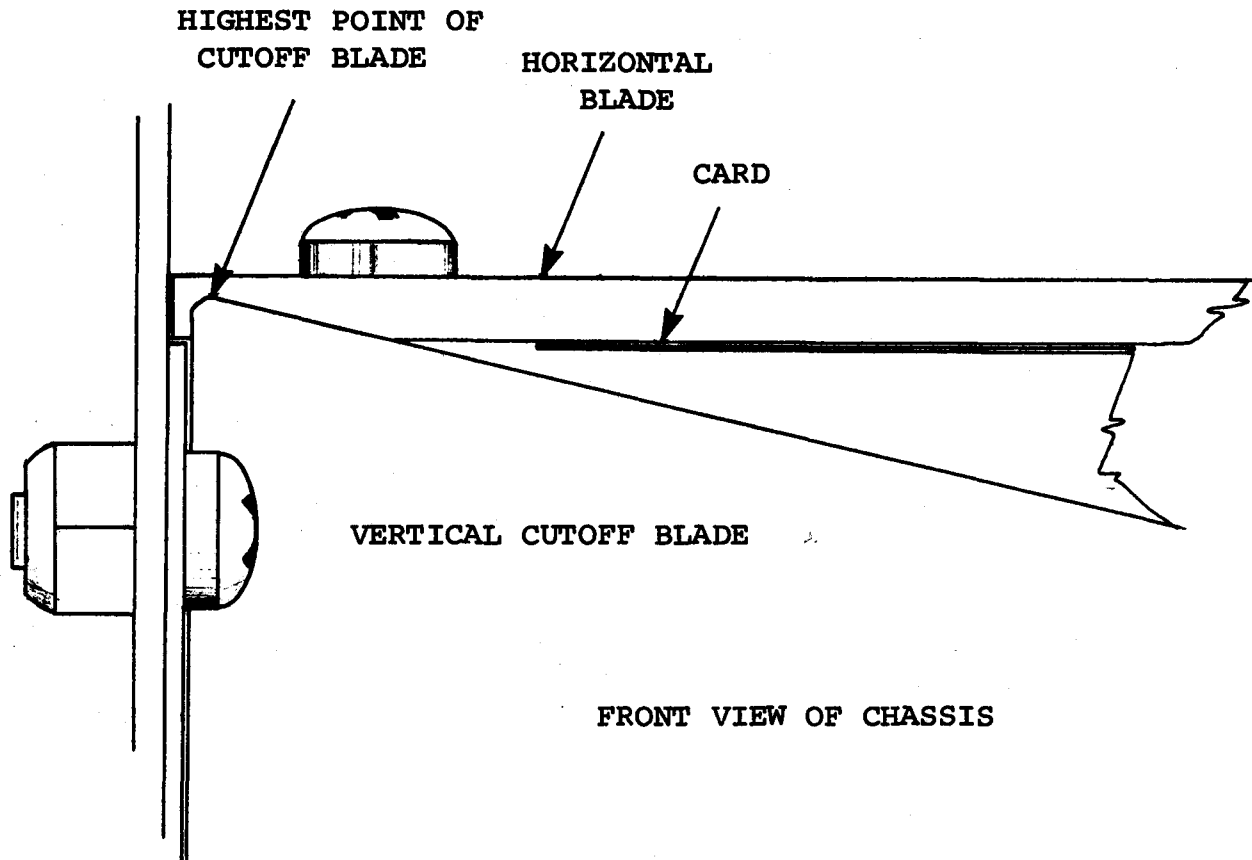
### Cut-off Blade Adjustment (see Figure 12)

Adjustment of the cut-off blade stop may be necessary after approximately 5000 vends.

The adjustment can be done without removing the chassis mechanism.

Locate the Allenhead adjuster screw at the under side of the mechanism.

This screw should be tightened until the highest point of the blade is in the position shown in the sketch below.



BIO-RHYTHM III

AC CABINET WIRING - 117 VAC

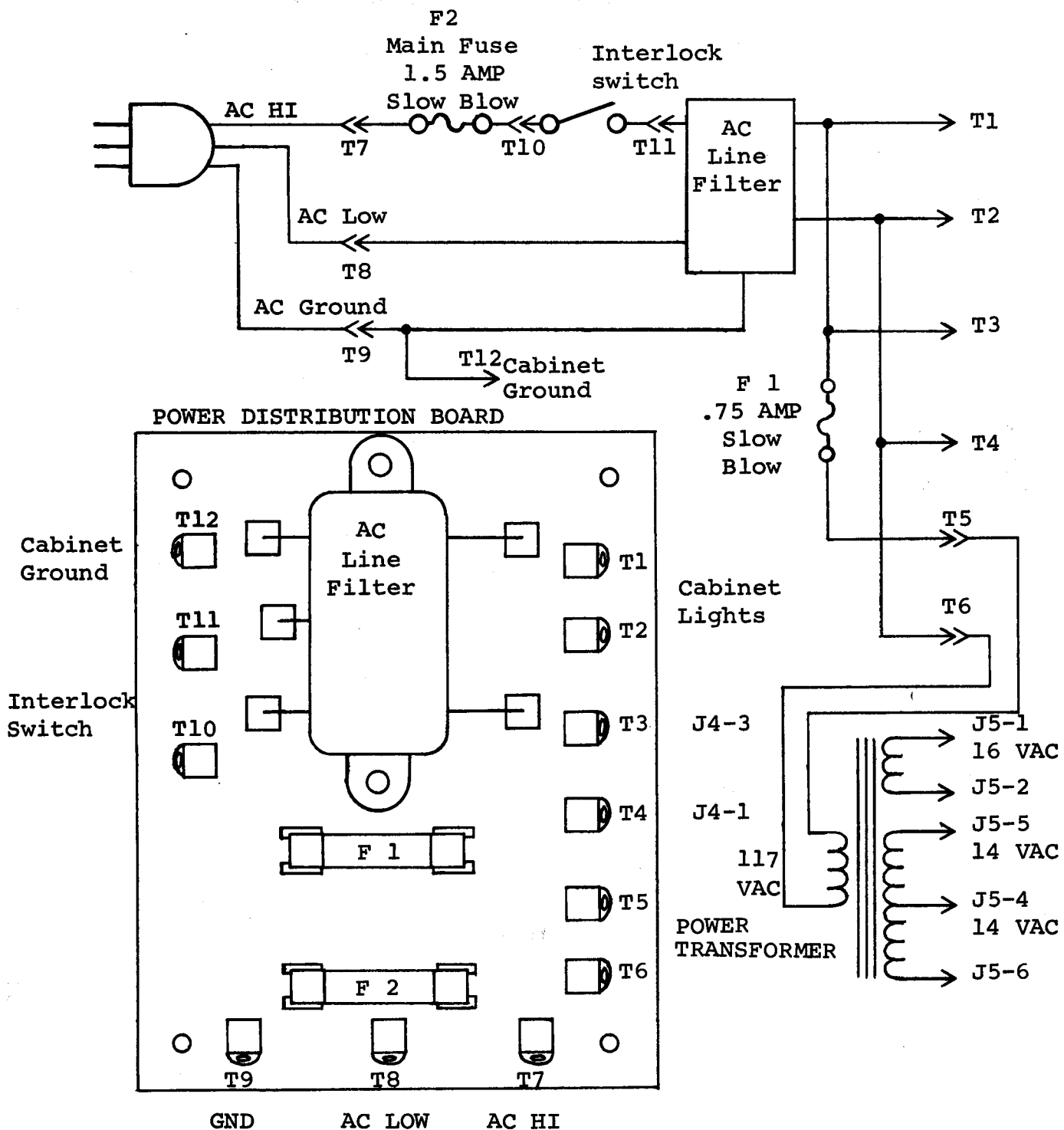


FIGURE 2  
(also see Figure 6)

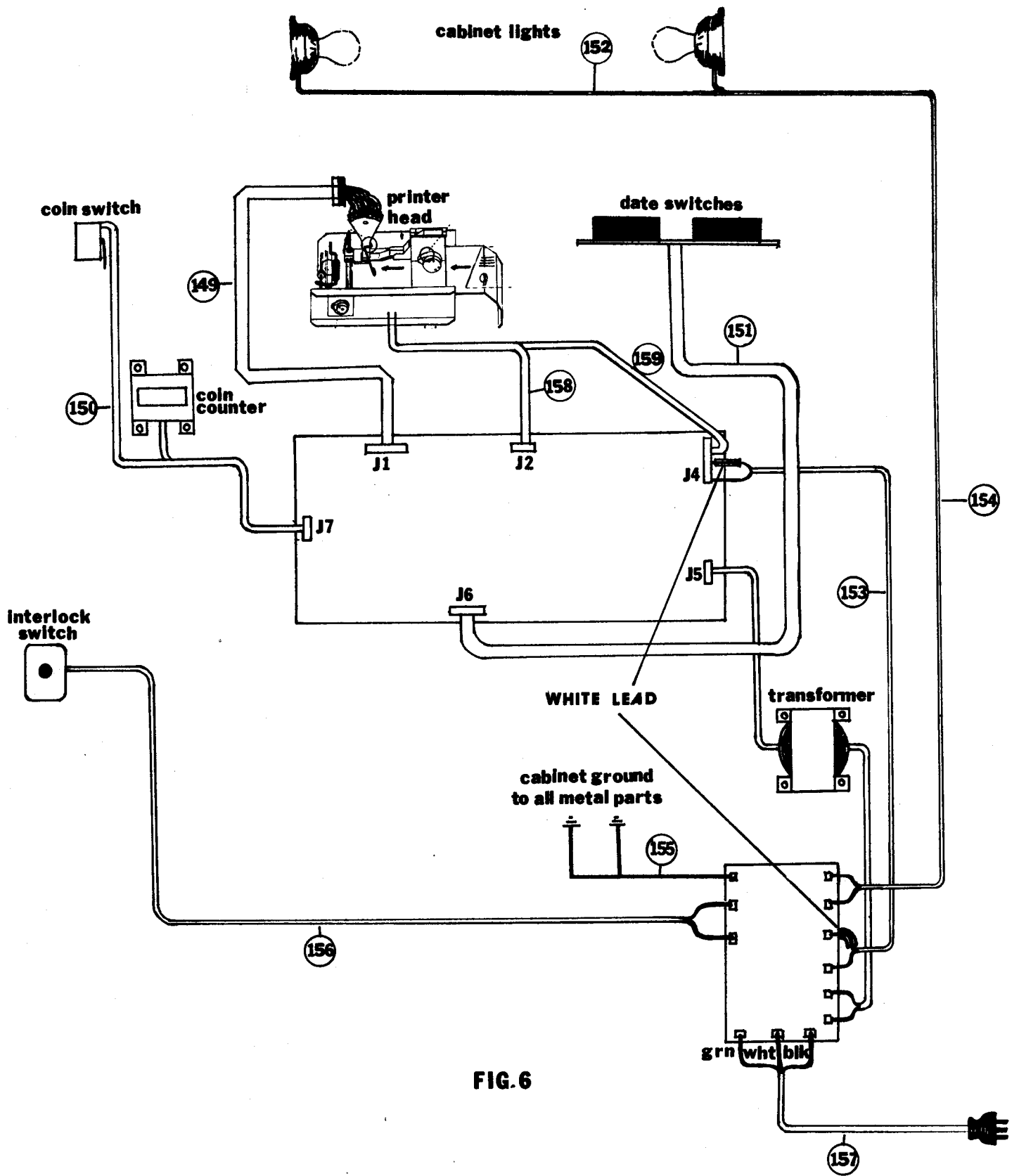
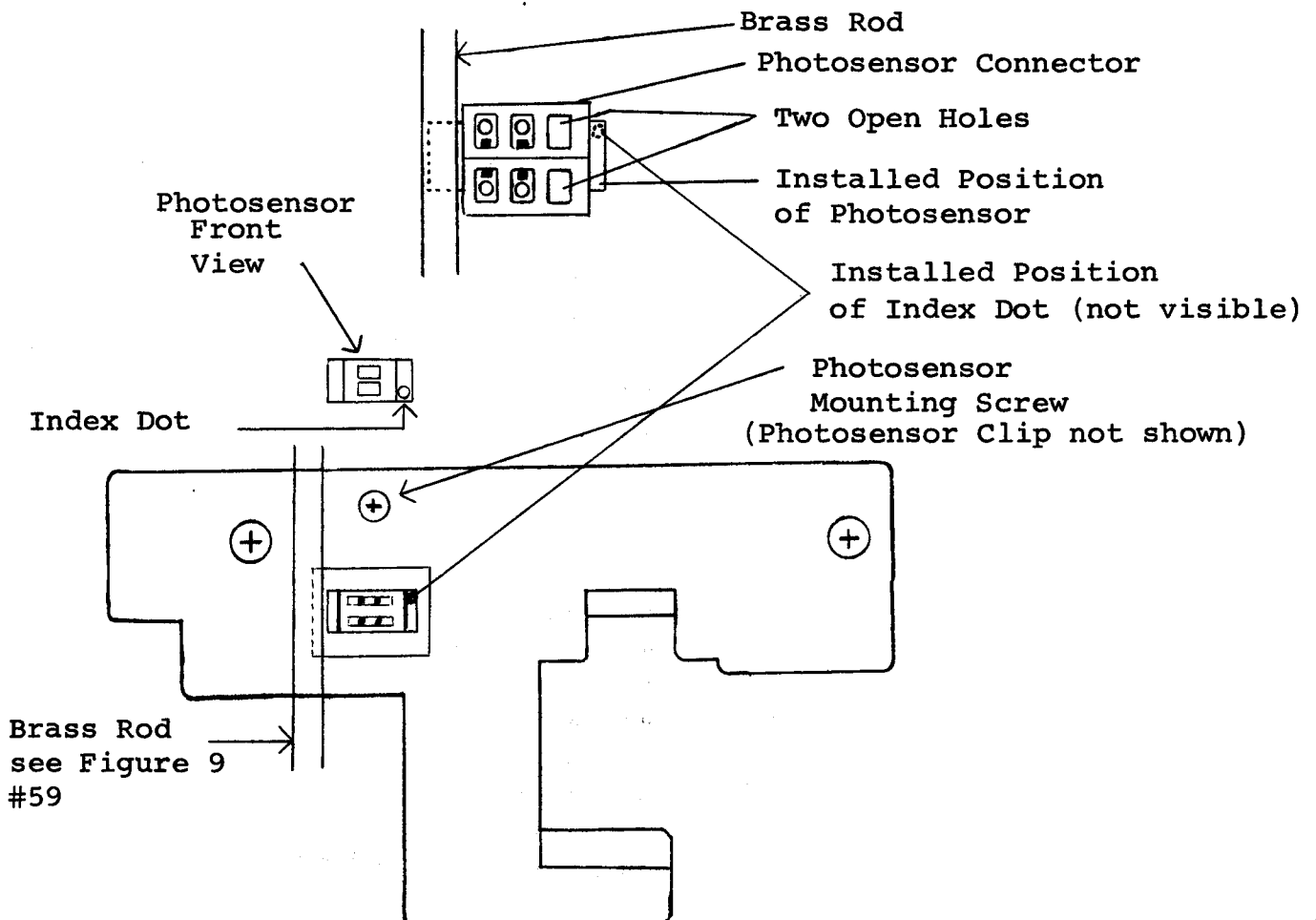


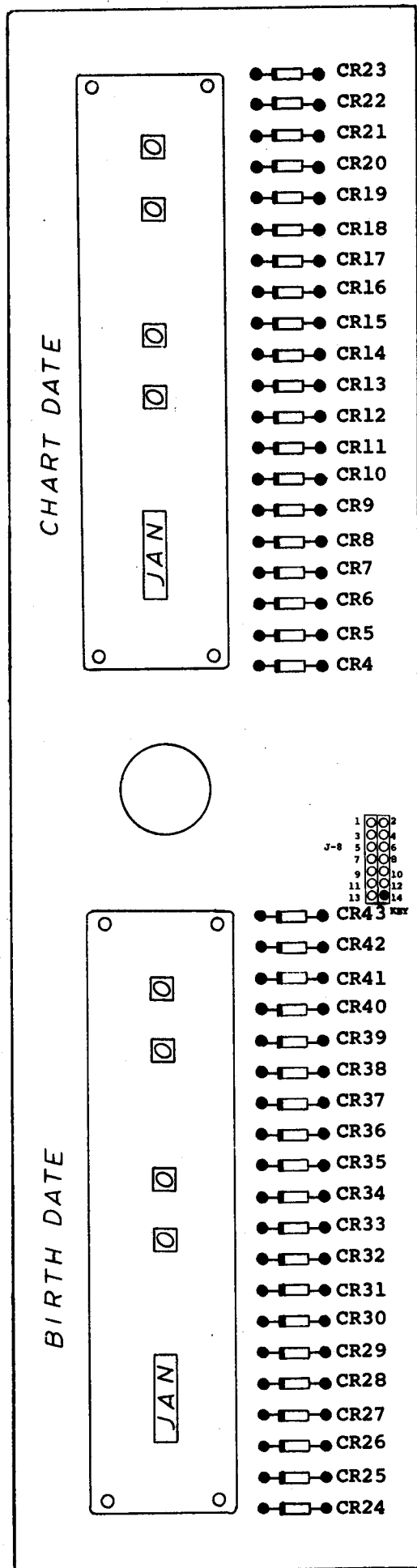
FIG. 6

## BIO-RHYTHM III PHOTSENSOR REPLACEMENT

---

1. Unplug machine
2. Lift Printhead out of the way
3. Move pen block back
4. Loosen photosensor mounting screw.
5. Tilt photosensor and connector towards pen block
6. Carefully withdraw photosensor connector with photosensor attached. Observe the position of the index dot, and replace photosensor - see below  
NOTE: Do not remove or disturb the coating on the face of the photosensor.
7. Reverse the previous steps to install a new photosensor - be sure that the connector is installed with the two open holes towards the ink tape cartridge. See Figure 9

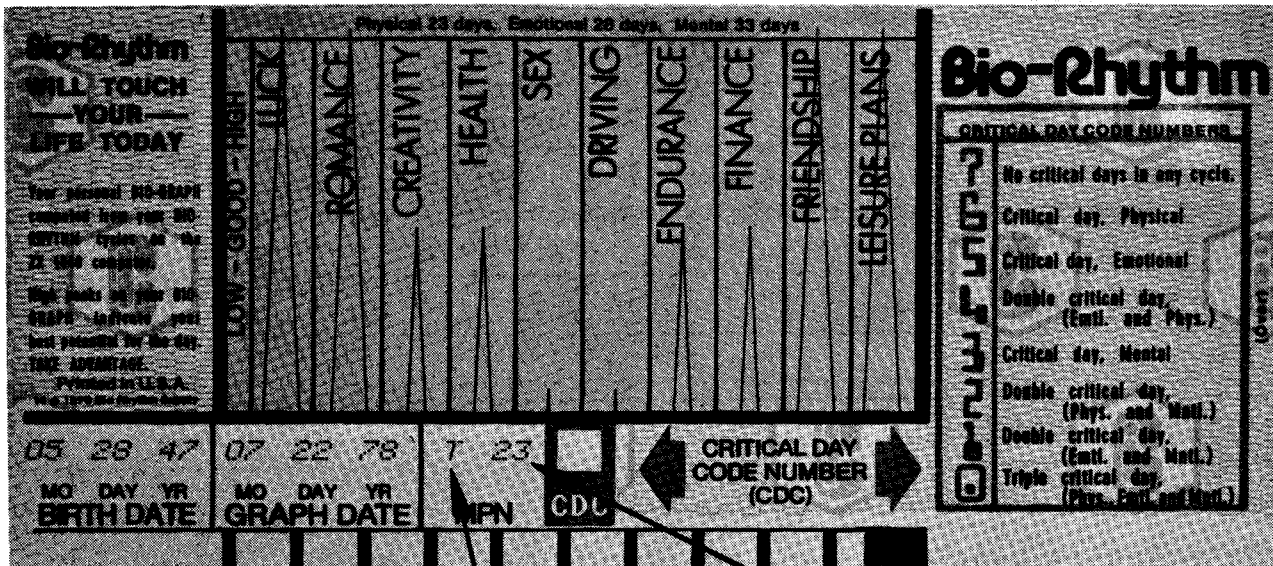




**FIG. 4**

BIO-RHYTHM III PHOTOSENSOR CHECK

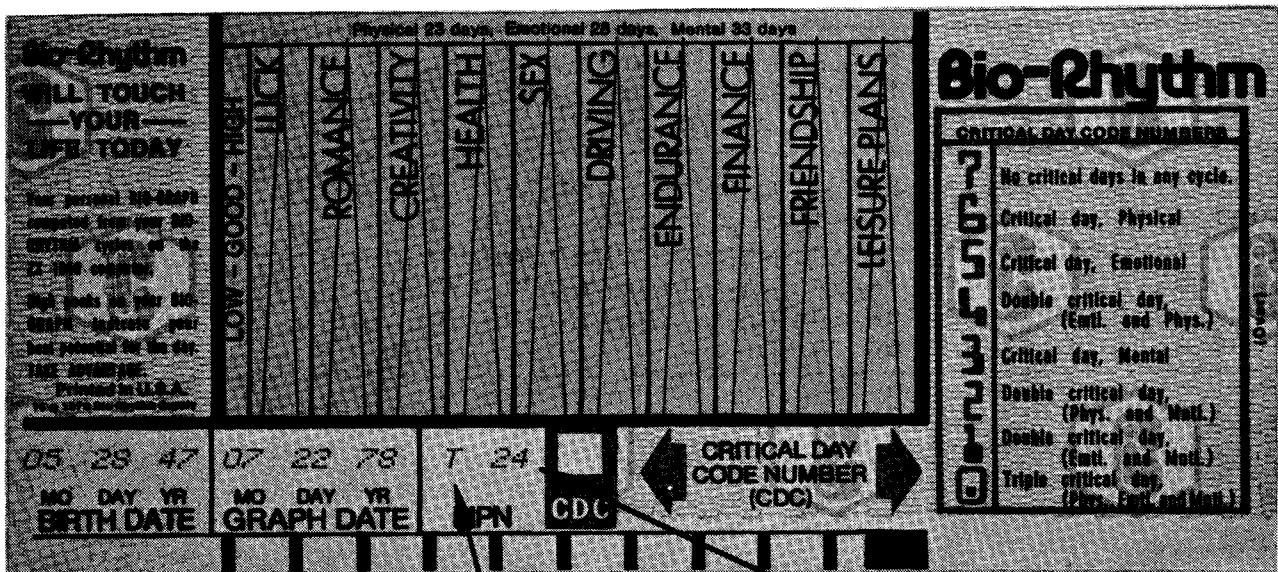
The photosensor is adjusted by the computer before running each card. A six-bit binary coded number is used to set the current for the photosensor. See examples below. In test mode, number is printed in after letter "T".



"1-COIN" TEST MODE

"TEST"

PHOTO CELL RANGE  
11 - 54



"2-COIN" TEST MODE

"TEST"

PHOTO CELL RANGE  
11 - 54

BIO RHYTHM - GENERAL TROUBLE-SHOOTING GUIDE

<u>SYMPTOMS OF PROBLEMS</u>	<u>CORRECTIONS</u>
1. Cards do not move.	R, C, E, W, Y
2. Cards do not cut-off.	D, N, V
3. Cards cut-off, do not fall down chute.	O
4. Pen does not move.	D, Q, R, U, Y
5. Pen does not write.	H
6. Pen does not return to rest position.	G, R, D, U
7. Pen skips.	H
8. Pen chatters while at rest position.	G, D
9. Ink tape does not move.	E, F, D, U
10. Ink tape has red dots 1/4" dia. on print surface.	S
11. Printing too light.	F, J, S, L
12. Printer missing dots or segments.	E, D, L
13. Printing wrong dates.	T, D, K
14. Printing is bunched up or spread out.	B, C, I
15. One of the motors stays on or will not turn on.	D
16. Sound does not come on, or stays on.	X, D, M
17. Lamp lit on Computer Board.	E, D
18. 115/230 VAC fuse blows.	P, V
19. Cards start moving but plots in wrong places, cards do not cut-off on the correct spot. After several tries, everything turns off.	B, C, E, N, Y
20. Cards start moving and stop after one-half inch, and will not restart with a coin.	B, C, D, Y
21. An unfinished card is in the chassis and has not been cut off, another coin will start the machine and will print a good card.	P, C, D, E, I

## BIO-RHYTHM - PROBLEM CORRECTIONS

- A. Out of Bio-Rhythm Cards.
- B. Paper stuck or jammed.
- C. Chart drive roller not pulling cards through chassis.
- D. Logic Board problem.
- E. Printer coil burned out - hammer stops cards & ink tape.
- F. Gear on tape cartridge not engaged properly.
- G. Pen Stop Switch stuck - bend metal tab towards nylon block.
- H. Out of ink - pen not touching card.
- I. Power failed while printing a card.
- J. Hammers not touching card - move hammer assembly down, be sure the printhead has clearance for the card and the ink tape.
- K. Check power supply voltages, +5V  $\pm$ 5%.
- L. +20 volt supply for hammer drivers too low.
- M. Turn blue pot on logic board to adjust sound.
- N. Stuck blade.
- O. Check card chute for any obstruction or rough spots.
- P. Short in motors, cabinet wires or transformer.
- Q. Pen Block stuck.
- R. Pen String loose or broken.
- S. Ink cartridge out of ink tape.
- T. Faulty date switch, or mis-wire.
- U. Cable unplugged or loose.
- V. Cut-off blade needs adjusting - jammed or stuck down.
- W. Cut-off blade has moved up and is jamming cards.
- X. Faulty speaker in chassis.
- Y. Photocell in chassis faulty or dirty, clean with clean soft dry brush, DO NOT use solvents or any type of liquid cleaner. If the computer stops, and will not restart with a coin, power must be turned off momentarily to clear the computer.
- Z. Power has been interrupted during play.



This  
page  
is  
Blank  
in this  
manual

BIO-RHYTHM III DATE ERROR EXAMPLES

Physical 23 days, Emotional 28 days, Mental 33 days

**Bio-Rhythm**  
WILL TOUCH YOUR LIFE TODAY

The personal BIRTHDAY computer from your 80 BIRTHDAY cycles in the 21 year computer.  
High peaks in your 80 BIRTHDAY cycles you are powerful for the day. TAKE ADVANTAGE. Printed in U.S.A. We give you the highest quality.

LOW - GOOD - HIGH  
LUCK  
ROMANCE  
CREATIVITY  
HEALTH  
SEX  
DRIVING  
ENDURANCE  
FINANCE  
FRIENDSHIP  
LEISURE PLANS

05 28 47 07 32 78 DATE? ?  
MO DAY YR MO DAY YR  
BIRTH DATE GRAPH DATE MPN CDC

CRITICAL DAY CODE NUMBER (CDC)

**Bio-Rhythm**  
CRITICAL DAY CODE NUMBERS

- No critical days in any cycle.
- Critical day, Physical
- Critical day, Emotional
- Double critical day, (Emtl. and Phys.)
- Critical day, Mental
- Double critical day, (Phys. and Mntl.)
- Double critical day, (Emtl. and Mntl.)
- Triple critical day, (Phys., Emtl. and Mntl.)

(10 year)

INVALID DATE

Physical 23 days, Emotional 28 days, Mental 33 days

**Bio-Rhythm**  
WILL TOUCH YOUR LIFE TODAY

The personal BIRTHDAY computer from your 80 BIRTHDAY cycles in the 21 year computer.  
High peaks in your 80 BIRTHDAY cycles you are powerful for the day. TAKE ADVANTAGE. Printed in U.S.A. We give you the highest quality.

LOW - GOOD - HIGH  
LUCK  
ROMANCE  
CREATIVITY  
HEALTH  
SEX  
DRIVING  
ENDURANCE  
FINANCE  
FRIENDSHIP  
LEISURE PLANS

05 28 47 02 29 49 DATE? ?  
MO DAY YR MO DAY YR  
BIRTH DATE GRAPH DATE MPN CDC

CRITICAL DAY CODE NUMBER (CDC)

**Bio-Rhythm**  
CRITICAL DAY CODE NUMBERS

- No critical days in any cycle.
- Critical day, Physical
- Critical day, Emotional
- Double critical day, (Emtl. and Phys.)
- Critical day, Mental
- Double critical day, (Phys. and Mntl.)
- Double critical day, (Emtl. and Mntl.)
- Triple critical day, (Phys., Emtl. and Mntl.)

(10 year)

FEBRUARY HAS ONLY 28 DAYS IN 1949.

Physical 23 days, Emotional 28 days, Mental 33 days

**Bio-Rhythm**  
WILL TOUCH YOUR LIFE TODAY

The personal BIRTHDAY computer from your 80 BIRTHDAY cycles in the 21 year computer.  
High peaks in your 80 BIRTHDAY cycles you are powerful for the day. TAKE ADVANTAGE. Printed in U.S.A. We give you the highest quality.

LOW - GOOD - HIGH  
LUCK  
ROMANCE  
CREATIVITY  
HEALTH  
SEX  
DRIVING  
ENDURANCE  
FINANCE  
FRIENDSHIP  
LEISURE PLANS

05 28 47 05 27 47 DATE? ?  
MO DAY YR MO DAY YR  
BIRTH DATE GRAPH DATE MPN CDC

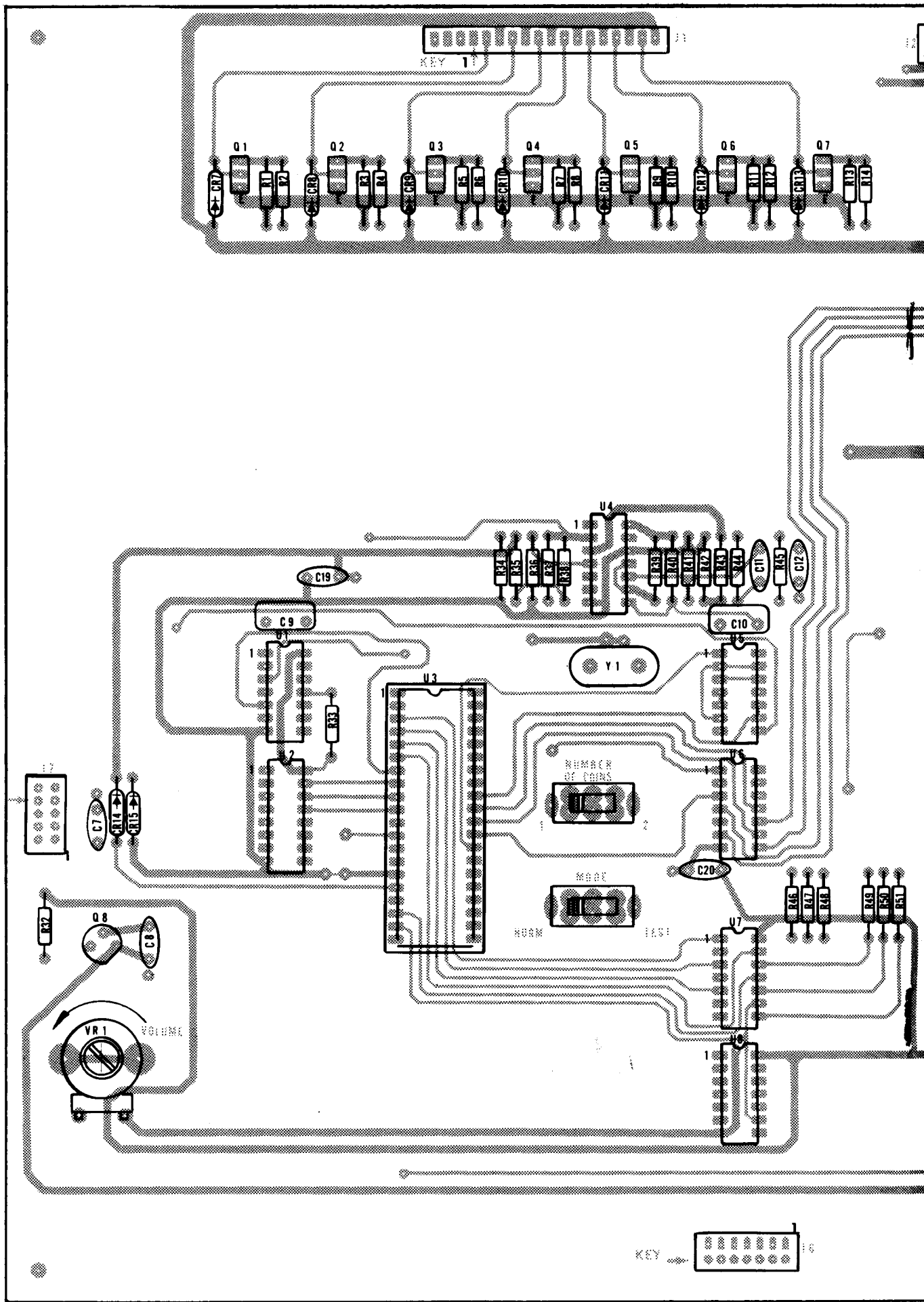
CRITICAL DAY CODE NUMBER (CDC)

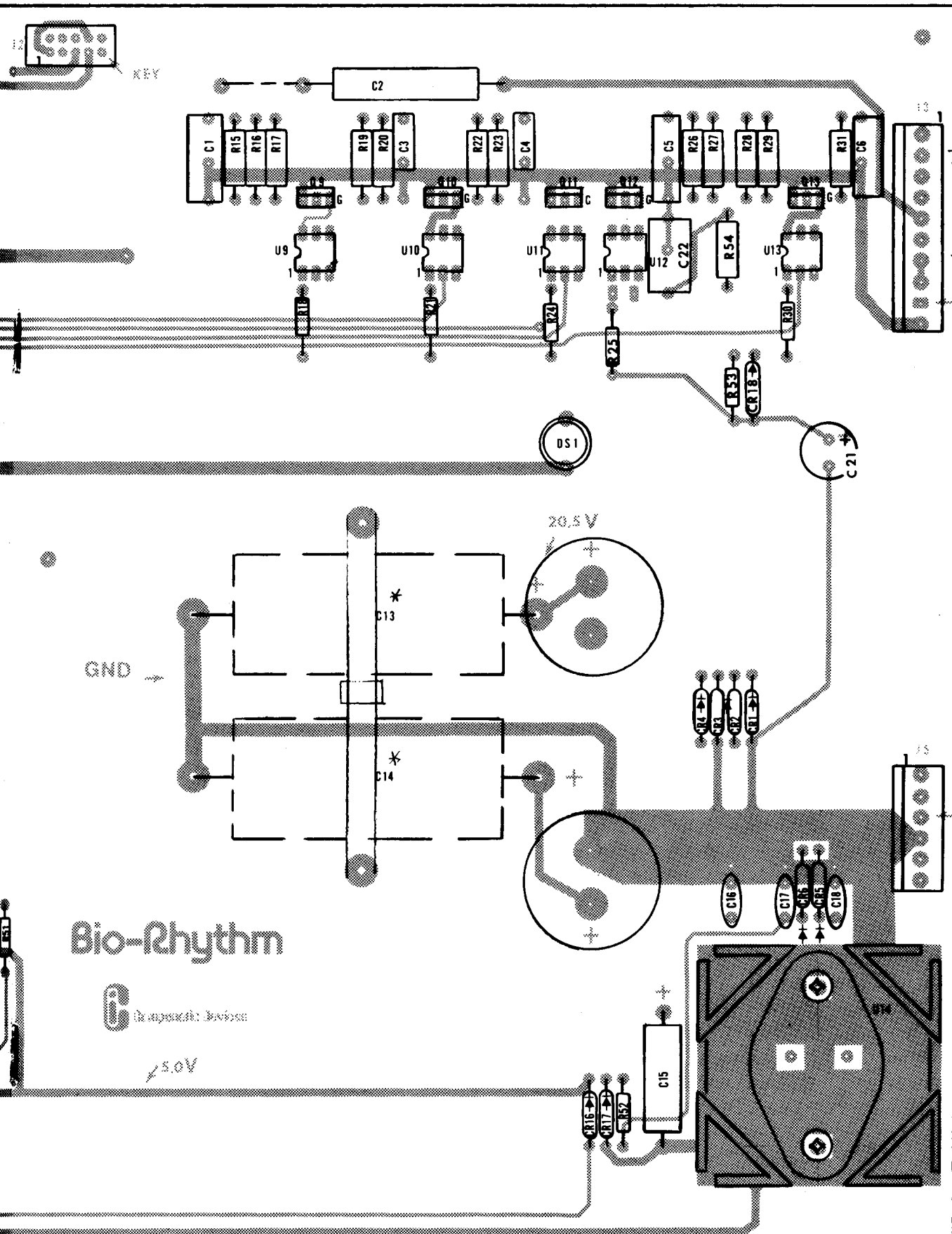
**Bio-Rhythm**  
CRITICAL DAY CODE NUMBERS

- No critical days in any cycle.
- Critical day, Physical
- Critical day, Emotional
- Double critical day, (Emtl. and Phys.)
- Critical day, Mental
- Double critical day, (Phys. and Mntl.)
- Double critical day, (Emtl. and Mntl.)
- Triple critical day, (Phys., Emtl. and Mntl.)

(10 year)

GRAPH DATE PRIOR TO BIRTH.





**F8 CIRCUIT DIAGRAM**

BIO-RHYTHM III

COMPUTER BOARD PARTS LIST (see Figure 3)

-----

ITEM	PART NO.	DESCRIPTION	MFGR.	QUAN.	REFERENCE
1	F3870 (CPU)	Integrated Circuit	FSC	1	U3
2	DM74121N	Integrated Circuit	NSC	1	U1
3	DM7445N	Integrated Circuit	NSC	1	U2
4	DM7407N	Integrated Circuit	NSC	1	U6
5	DM74LS05N	Integrated Circuit	NSC	2	U7,U8
6	DM74LS00N	Integrated Circuit	NSC	1	U5
7	LM309K	Integrated Circuit	NSC	1	U14
8	LM339N	Integrated Circuit	NSC	1	U4
9	2N6034	Transistor, PNP Darlington	MOT	7	Q1-Q7
10	2N3643	Transistor, NPN MPWR	NSC	1	Q8
11	1N4002	Diode, 1 Amp, 100 PIV	MOT	20	CR1-CR20
12	1816	Lamp, Incandescent	GE	1	DS1
13	4719-001	Lamp Holder (CAL 024-531)	Drake	1	
14	MOC3010	Opto-Isolator	MOT	5	U9-U13
15	T2800D	Triac, 400V	RCA	5	Q9-Q13
16	10SP002	Switch, DPDT	MOU	2	S1,S2
17	3.58 MHz	Crystal, Color Burst	BRK	1	Y1
18	10K Ohm	Resistor, 1/4W, 5%		7	R1,3,5,7,9,11,13
19	5.1K Ohm	Resistor, 1/4W, 5%		9	R2,4,6,8,10,12, 14,36,44
20	20K Ohm	Resistor, 1/4W, 5%		5	R34,35,39,41,42
21	470 Ohm	Resistor, 1/4W, 5%		1	R32
22	15K Ohm	Resistor, 1/4W, 5%		1	R43
23	2.2 Megohm	Resistor, 1/4W, 5%		1	R40
24	300 Ohm	Resistor, 1/4W, 5%		5	R18,21,24,25,30
25	100 Ohm	Resistor, 1/4W, 5%		1	R53
26	51K Ohm	Resistor, 1/4W, 5%		1	R38
27	30K Ohm	Resistor, 1/4W, 5%		1	R33
28	4.7K Ohm	Resistor, 1/4W, 5%		3	R37,45,52
29	22 Ohm	Resistor, 1/2W, 5%		2	R17,28
30	180 Ohm	Resistor, 1/2W, 5%		6	R15,19,22,26,31,54
31	330 Ohm	Resistor, 1/2W, 5%		5	R16,20,23,27,29
32	10K Ohm	Potentiometer	CTS	1	VR1
33	249 Ohm	Resistor, 1/8W, 1%		1	R50
34	499 Ohm	Resistor, 1/8W, 1%		1	R51
35	1K Ohm	Resistor, 1/8W, 1%		1	R49
36	2K Ohm	Resistor, 1/8W, 1%		1	R46
37	4.02K Ohm	Resistor, 1/8W, 1%		1	R47
38	8.06K Ohm	Resistor, 1/8W, 1%		1	R48

BIO-RHYTHM III

COMPUTER BOARD PARTS LIST (Cont'd)

ITEM	PART NO.	DESCRIPTION	MFGR.	QUAN.	REFERENCE
39	23MP410	Capacitor, Non Ind. .1MFD, 250V	MOU	4	C1,5,6,22
40	23MP310	Capacitor, Non Ind. .01MFD, 250V	MOU	2	C3,4
41	21KF010	Capacitor, Ceramic .01MFD, 50V	MOU	1	C11
42	21ET100	Capacitor, Ceramic .10MFD, 50V	MOU	7	C8,12,16-20
42A		Capacitor, Tantalum 22MFD, 16V		1	C7
43	23AK410	Capacitor, Mylar .10MFD, 25V	MOU	2	C9,10
44	20NM905	Capacitor, Alum. Elec. 2000 MFD/ 40VDC; 2200MFD, 350V	MOU	2	C13,14
45	23MA510	Capacitor, Mylar 1.0MFD, 250VDC	MOU	1	C2
46	20RH022	Capacitor, Alum. Elec. 22MFD, 25V	MOU	1	C15
47	20XK100	Capacitor, Alum. Elec. 100MFD, 25V	MOU	1	C21
48	22-03-2181	Connector, 18 Pins	Molex	1	J1
49	22-03-2051	Connector, 5 Pins	Molex	2	J2
50	09-65-1101	Connector, 10 Pins	Molex	1	J3
51	09-60-1061	Connector, 6 Pins	Molex	1	J5
52	22-03-2071	Connector, 7 Pins	Molex	2	J6,
53	22-03-2051	Connector, 5 Pins	Molex	2	J7
54	C854000	Socket, IC, DIP, 40 Pin	TI	1	
55	6016B	Heatsink	Thermalloy	1	
56	6-32	Mounting Hardware, Screws and Nuts		2	
57		P.C. Board			

POWER DISTRIBUTION BOARD PARTS LIST (see Figure 2)

-----

<u>REF. NO.</u>	<u>PART NO.</u>	<u>DESCRIPTION</u>
---	29-7436	Clip, Fuse - P/C Mount
---	29-7453	Connector, Blade .187 Male
---	14-869	Filter, Line - 1B1 Corcom
---	25-387	Fuse, 3AG, 1.5 Amp, Slow-Blow, 125V
---	25-386	Fuse, 3AG, .75 Amp, Slow-Blow, 125V
---	7-264	P.C. Board - Assembled

BIO-RHYTHM III

DATE SWITCH BOARD PARTS LIST (see Figure 3)  
-----

<u>REF. NO.</u>	<u>PART NO.</u>	<u>DESCRIPTION</u>
---	13-1132	Switch, Date
---	29-7433	Connector, 7 Pin, Wafer, J8
---	17-460	Diode, 1N 4148
---	7-259	P.C. Board - Assembled

CABINET PARTS LIST (see Figures 5, 13 & 14)  
-----

<u>REF. NO.</u>	<u>PART NO.</u>	<u>DESCRIPTION</u>
1	7-272	Chassis Mechanism
2	22-1416	Assy., Reel Frame - Complete
3	22-1429	Retainer Card Reel - Complete
4	27-381	Cord, AC, SJT 18-3 12'
5	618-159	Transformer, Auto, Export
6	29-7253	Clip, Fuse, Export
7	25-377	Assy., Case Foot
8	25-384	Glide, Leg
9	3-416	Cap, Leg
10	22-1492	Reel, Card (End Plate)
11	26-1145	Dowel, Wood
12	22-1498	Assy., Card Reel
13	25-311	Clamp, Cable, 3/8 Nylon
14	18-467	Transformer, Power - Wired
15	3-446	Cover, Power Board
16	7-264	P.C. Board, Power, Assembled
17	1-1113	Standoff - 1/4"
18	7-257	P.C. Board, Main, Assembled
19	25-381	Standoff, Circuit Board, 3/4"
20	25-382	Standoff, Circuit Board, 1-3/8"
21	22-1430	Shelf, Printer
22	3-419	Strain Relief - Black
23	3-436	Cup, Coin
24	25-400	Counter, Coin
25	22-1425	Stop, Dress Panel
26	25-378	Hinge Top, Complete
27	3-440	Trim, Rubber U Channel
28	3-433	Panel, Glass Bottom
29	3-439	Trim, Plastic Extrusion
30	3-438	Trim, Plastic Extrusion
31	3-440	Trim, Rubber U Channel
32	3-437	Trim, Plastic Ext. Upper Glass
33	3-432	Panel, Glass Upper
34	3-438	Trim, Plastic Ext.

BIO-RHYTHM III

CABINET PARTS LIST (Cont'd)

<u>REF. NO.</u>	<u>PART NO.</u>	<u>DESCRIPTION</u>
35	22-1440	Retainer, Glass Top
36	22-1439	Shield, Viewing
37	29-7451	Receptacle, Lamp
38	24-539	Flasher, 120V, 60 Watts
39	24-540	Bulb, Incan. 25W
40	22-1496	Bulkhead, Rear - Cabinet
41	3-434	Trim, Cap - Chrome
42	22-1441	Assy., Retainer Glass Center
43	22-1442	Assy., Retainer Glass Bottom
44	22-1422	Assy., Coin Chute - Complete
45	22-1448	Brkt., Lock Striker - Complete
46	22-1467	Box, Coin Top Rail
47	22-1495	Box, Coin - Complete
48	22-1468	Box, Coin - Bottom Bracket
49	13-1134	Switch, Interlock
200	25-401	Assy., Coin Mechanism
201	22-1465	Coin Chute - Front Mtg.
201	22-1466	Coin Chute - Rear Mtg.
202	3-392	Chute, Switch
203	22-1435	Barrier, Trip Switch
204	22-1494	Retainer, Lock
205	25-402	Lock
206	22-1444	Hook Lock - Complete
207	13-1116	Switch, Coin Mechanism
208	25-403	Key, Door
220	1-1111	Rod, Reject
221	1-1110	Case, Reject Rod
222	16-176	Lockwasher, 5/8 Int.
223	28-9094	Nut, Shear 5/8-11
224	25-383	O-Ring, 1/4 ID x 3/8 OD x 1/16
225	19-712	Spring, Reject
226	16-179	Washer, Flat, 1/4 x 1/2
227	50-127	Ring, Retainer, .250 Dia. Shaft
228	22-1432	Bezel, Coin Slot
229	22-1427	Receiver, Card
230	22-1426	Guide, Card
231	7-259	P.C. Board - Date Switch, Assembled
232	13-1132	Switch, Date
233	22-1431	Panel, Dress

CHASSIS PARTS LIST

-----

<u>REF. NO.</u>	<u>PART NO.</u>	<u>DESCRIPTION</u>
52	10-59	Lug, Pen Spring Attach
53	25-375	Pen Cartridge
55	22-1493	Lever, Pen Lifter



BIO-RHYTHM IIICHASSIS PARTS LIST (Cont'd)

<u>REF. NO.</u>	<u>PART NO.</u>	<u>DESCRIPTION</u>
56	19-713	Spring, Pen
57	29-7450	Cotter Pin, 3/32 x 1"
58	1-1112	Block Pen
59	1-1106	Shaft, Pen/Roller
60	19-710	Spring, Blade
61	28-9091	Nut, Speed Push-On .187 Tinn.
62	13-1133	Switch, Pen
62-A	3-447	"O" Ring, Pen Switch
63	22-1475	Brkt., Mounting Switch
64	1-1079	Spacer, Photosensor Clip
65	22-1477	Clip, Photosensor
66	17-525	Photosensor
67	25-390	Assy., Pinch Roller
68	3-449	Brkt., Reader Pen Switch
69	25-391	Clip, Retainer
69-A	25-392	E Ring, .125 Shaft
70	19-709	Spring, Blade Return
71	3-443	Guide, Card - Right
72	3-444	Guide, Card - Left
73	22-1491	Blade, Vertical
74	1-1107	Roller, Blade
75	22-1472	Spacer, Blade, Horizontal
76	22-1489	Wearstrip Blade
77	19-711	Spring, Pinch Roller Assy.
78	1-1106	Shaft, Blade/Roller
79	22-1473	Blade, Horizontal
80	1-1082	Bushing, Chart Roller
81	1-1078	Roller, Chart
81-A	28-9092	Nut Plate 10-32
82	16-180	Washer, .141 ID x 1/2 OD x .040
83	16-182	Washer, Flat, #6 x 1/4 OD
85	2-421	Screw, 5-40 x 1/2
86	25-398	Assy., Belt, Pen Drive
87	25-393	Assy., Pulley
88	25-396	Clamp, Cable, Nylon 1/8"
89	1-1098	Spacer, Pen Driver, Center
90	1-1097	Spacer, Pen Drive
91	1-1105	Spacer, .25 OD x .190 ID x .151
92	30-128	Assy., Motor, Pen Drive
93	19-714	Spring, Pen Motor
103	29-7437	Cotter Pin, 1/16 Dia x 3/4L
104	1-1077	Pin, Clevis Printhead
105	22-1487	Bracket, Printer
106	25-389	Printhead
107	18-468	Solenoid, Printhead
108	22-1488	Latch, Printer
117	22-1490	Latch, Ribbon
118	1-1081	Spacer, Ribbon Motor
119	22-1478	Brkt., Top Ribbon Motor
120	22-1479	Brkt., Bottom Ribbon Motor

BIO-RHYTHM III

CHASSIS PARTS LIST (Cont'd)

<u>REF. NO.</u>	<u>PART NO.</u>	<u>DESCRIPTION</u>
121	22-1471	Support Ribbon
122	30-124	Assy., Motor, Ribbon Drive
123	25-372	Assy., Cartridge Typewriter Ribbon
124	1-1080	Gear, Boston
133	20-63	Speaker
134	22-1483	Blade, Lifter
136	18-464	Solenoid, Cut-off
137	16-181	Washer, .188 ID x 5/8 OD x .063
138	1-1107	Roller, Blade
139	1-1095	Spacer, Solenoid
140	1-1108	Pin, Solenoid
141	28-9091	Nut, Speed Push-On .187 Tinn.
142	28-9090	Nut, Lockplate, 3/8-24
143	22-1482	Angle, Blade Stop Adj.
144	2-416	Screw, 3/8-24 x 1
145	19-715	Spring, Blade Lifter
160	30-126	Assy., Motor, Chart Drive
161	22-1484	Brkt., Chart Mounting
162	1-1083	Assy., Coupler

CABLE PARTS LIST (see Figure 6)  
-----

<u>REF. NO.</u>	<u>PART NO.</u>	<u>DESCRIPTION</u>
150	27-380	Assy., Coin Counter & Switch Harness
151	27-373	Assy., Date Switch Harness
152	27-377	Assy., Light Jumper Harness
153	27-391	Assy., Power to Main Board Harness & Chassis
154	27-378	Assy., Main Light Harness
156	27-379	Assy., Interlock Cable
157	27-381	Cord, AC, SJT 18-3 12'
158	27-376	Assy., Chassis Photosensor Harness

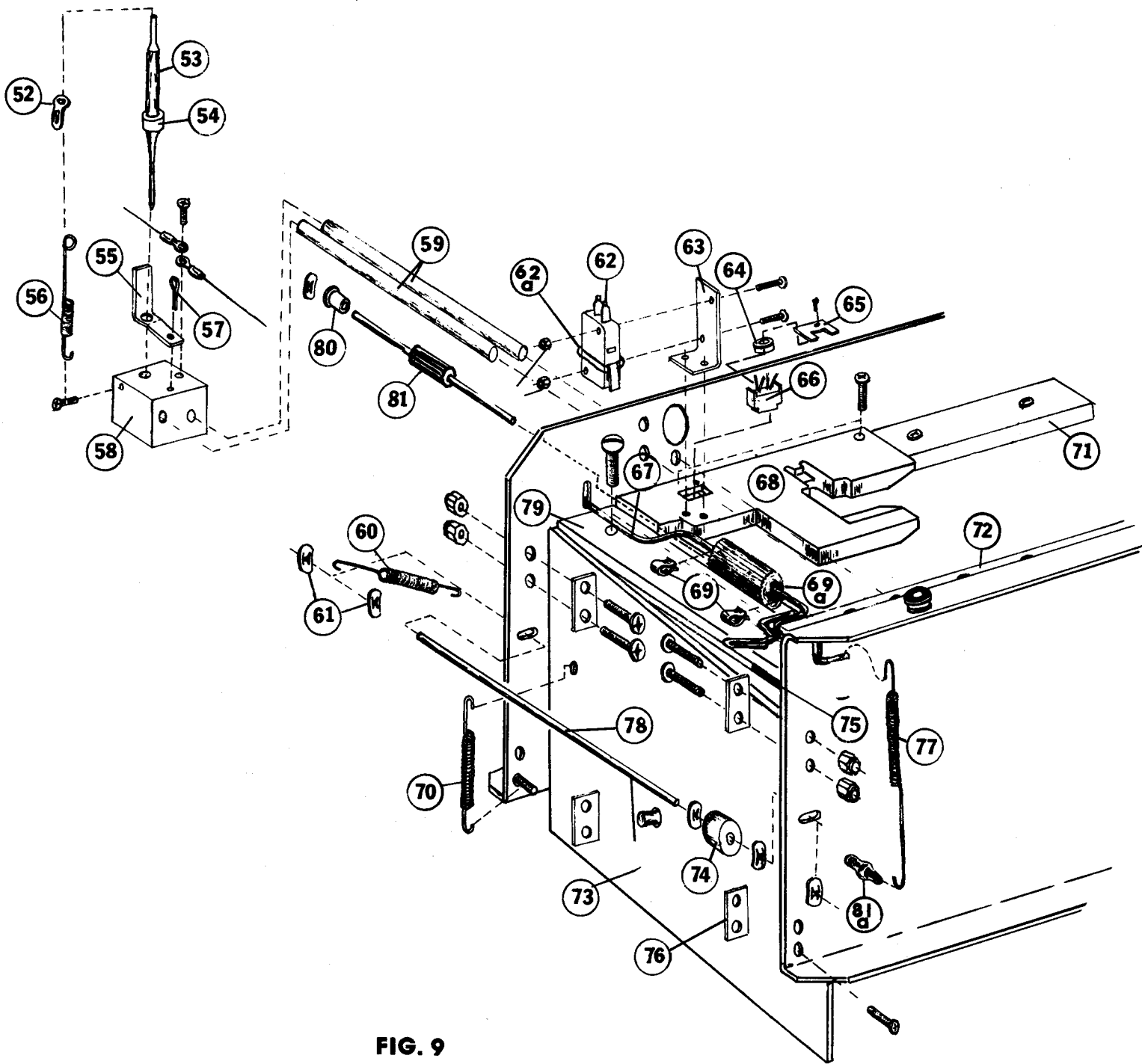
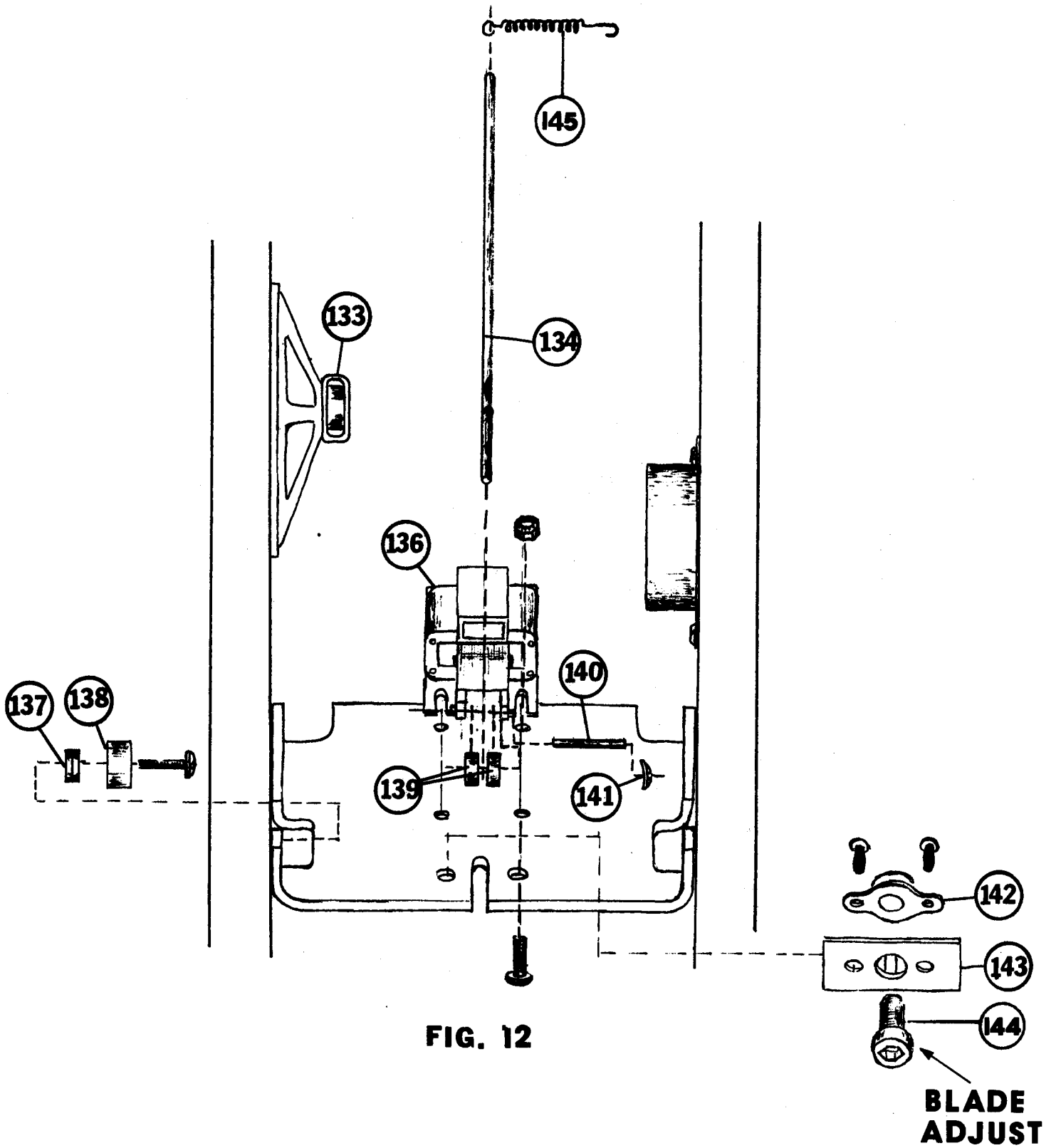
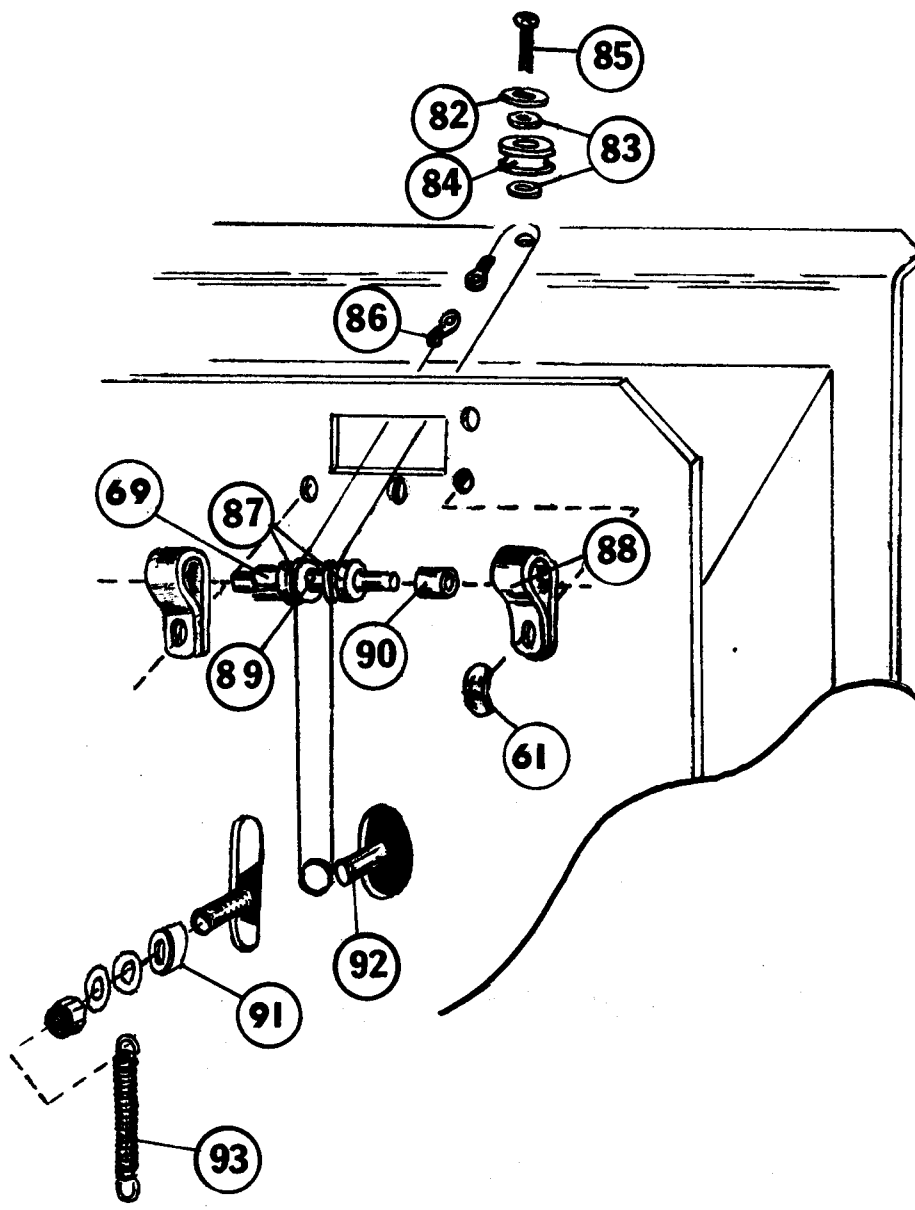


FIG. 9





**FIG. 11**

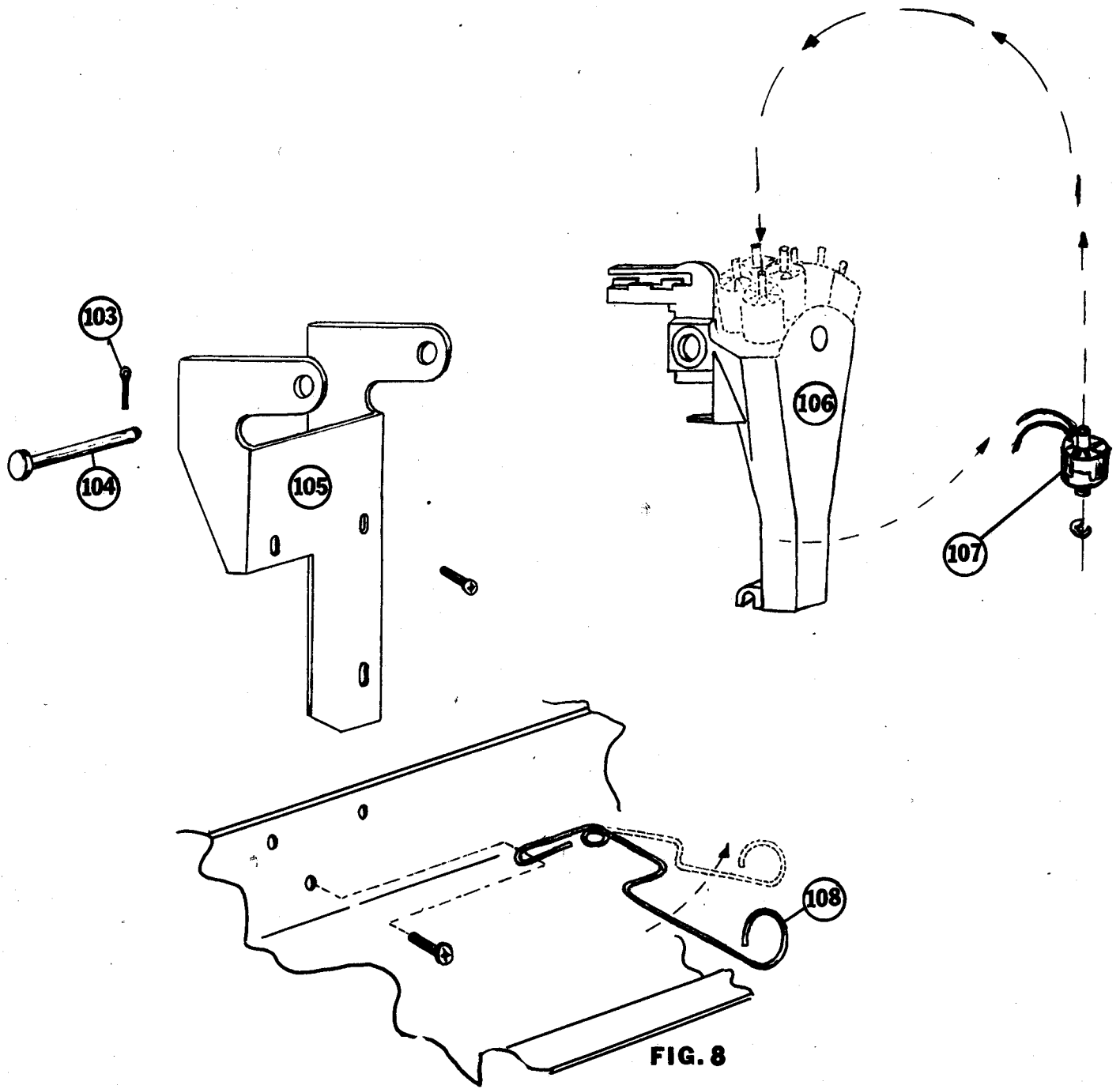


FIG. 8

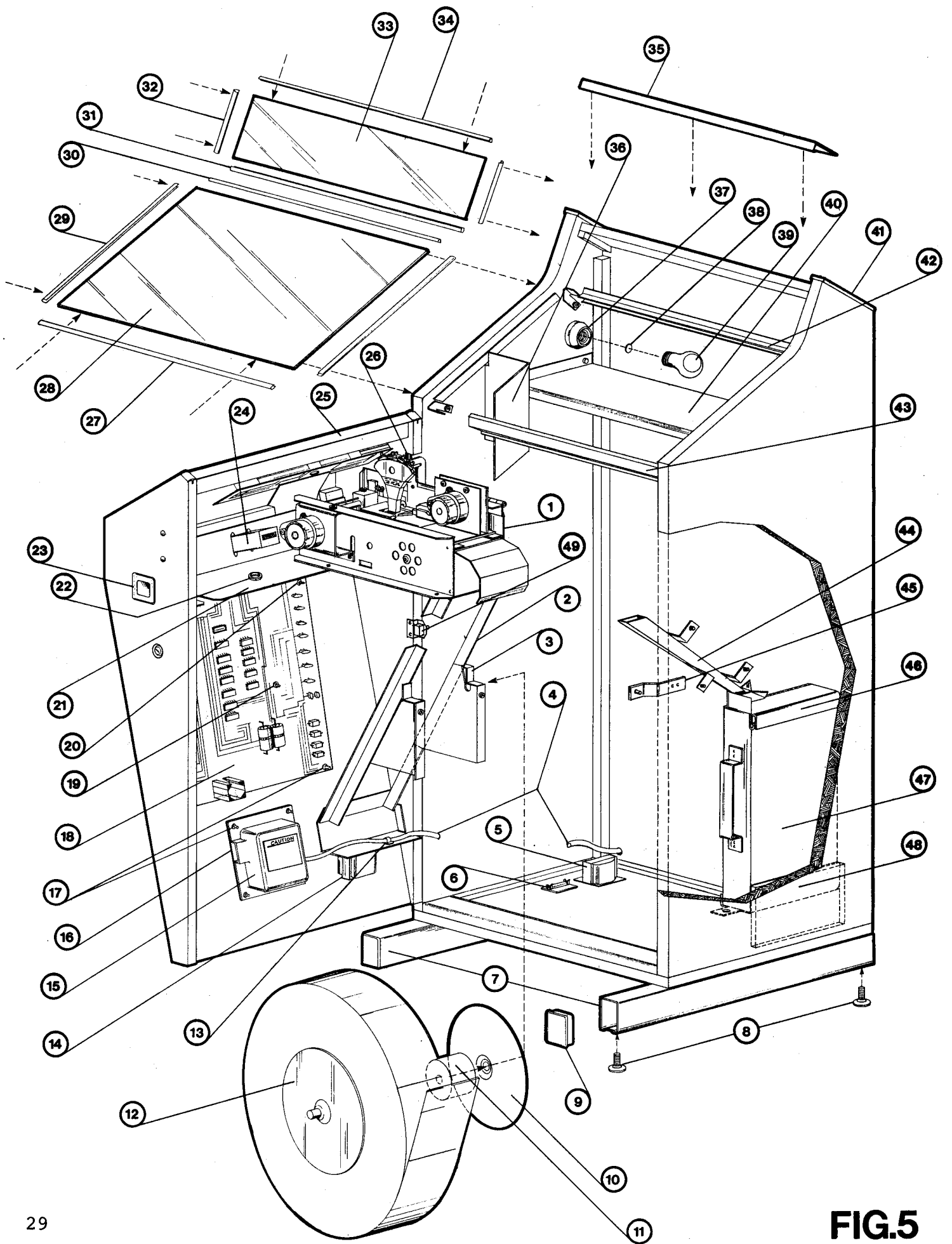
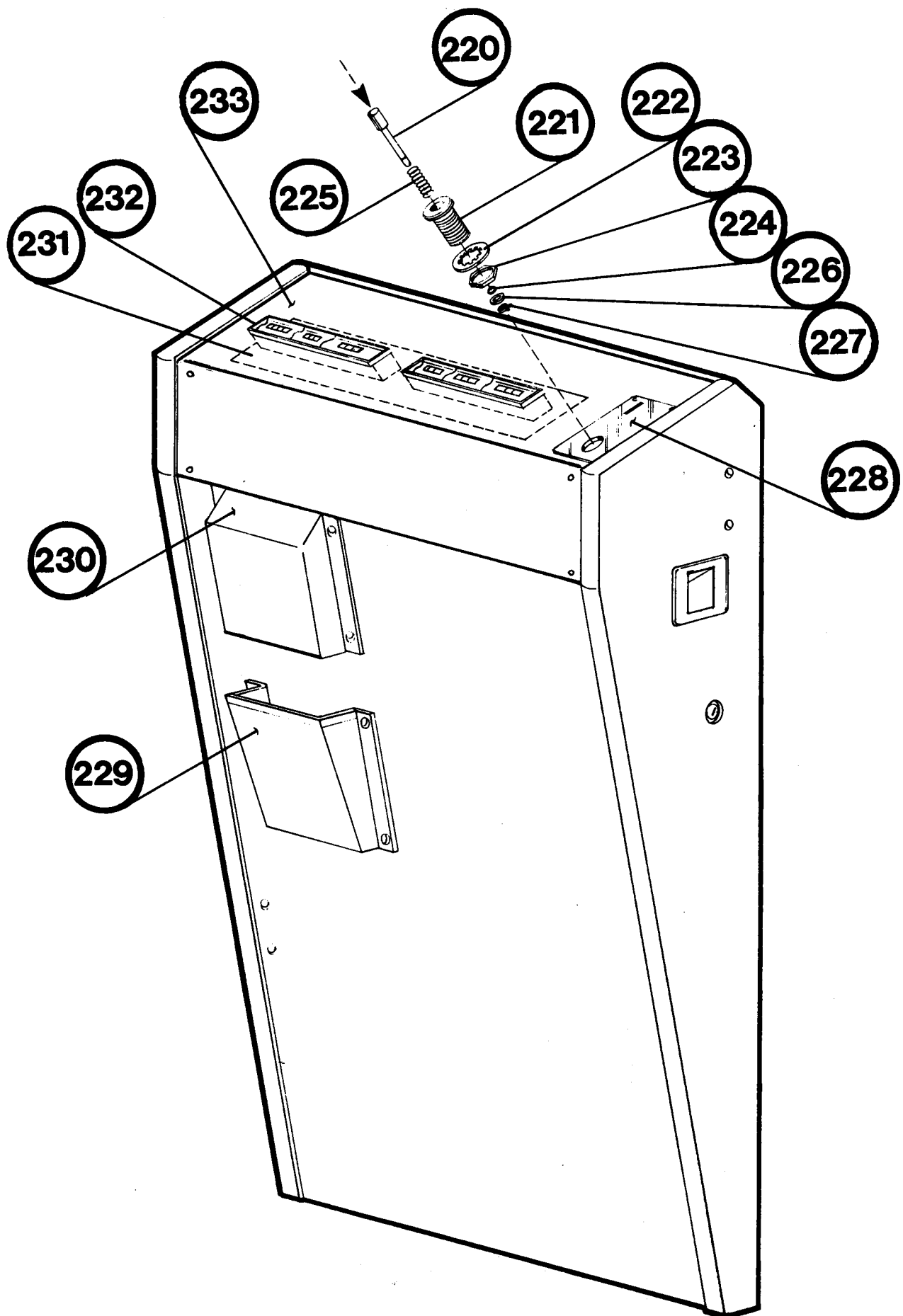
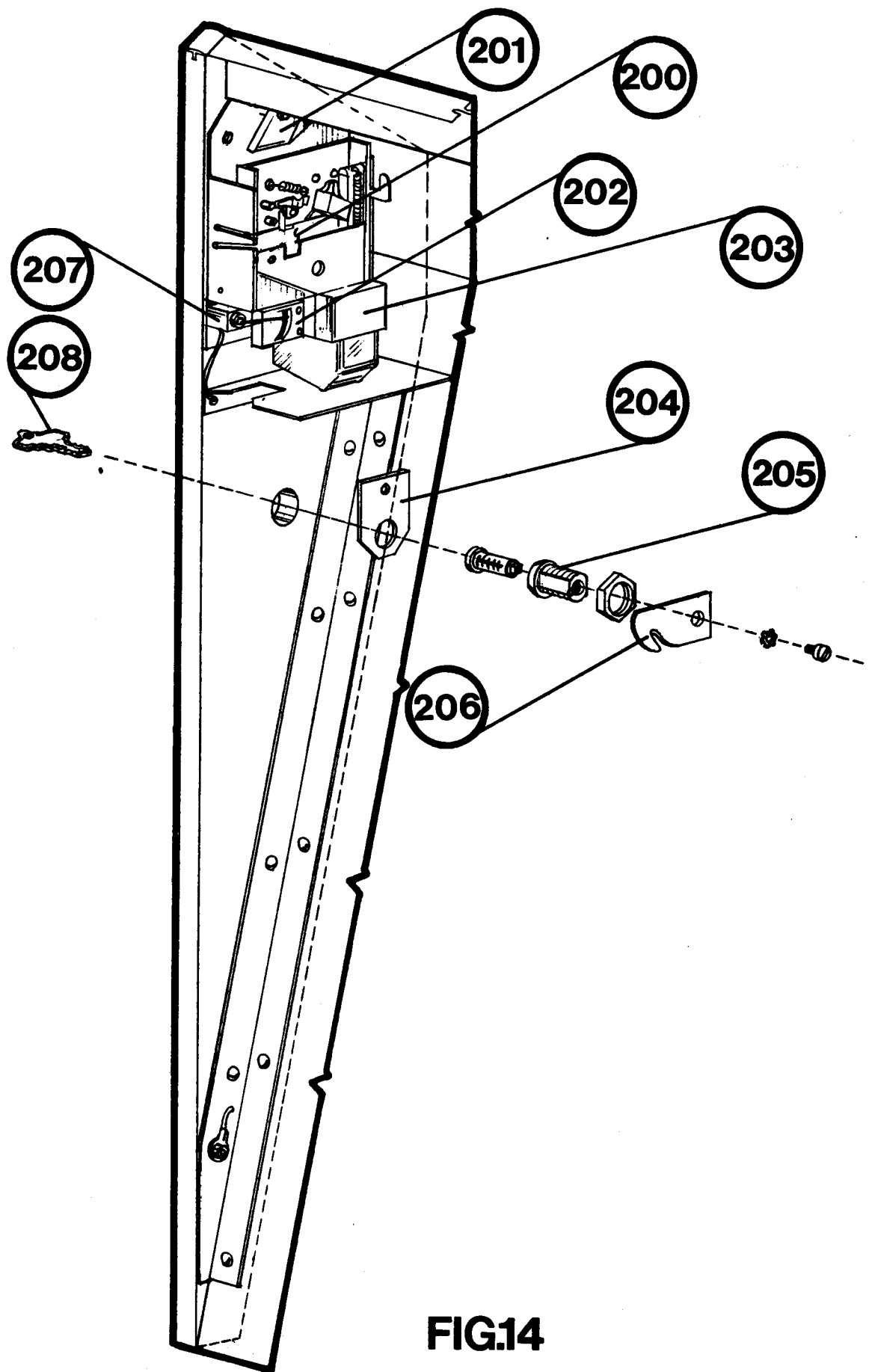


FIG.5

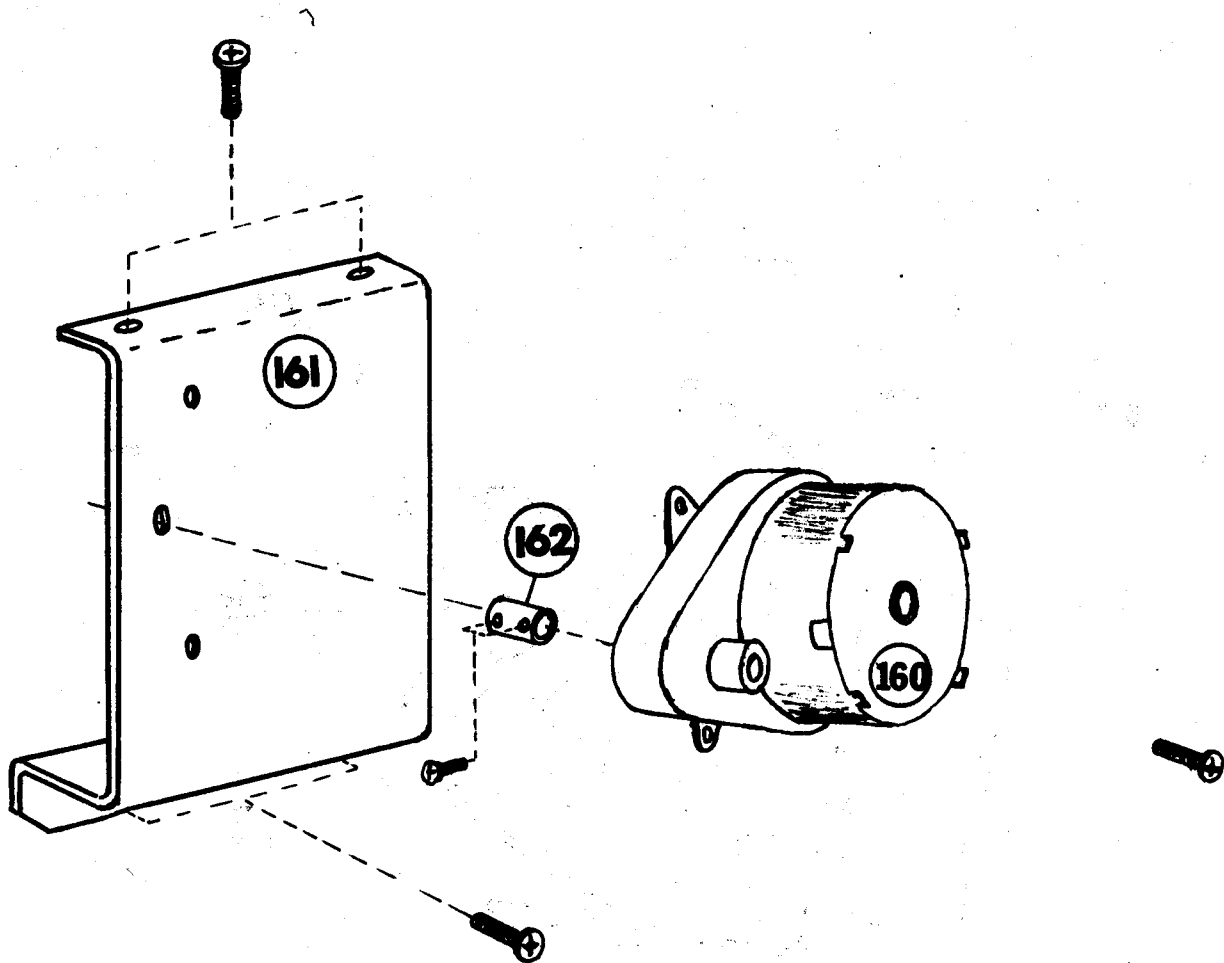


**FIG.13**





**FIG.14**



**FIG. 7**

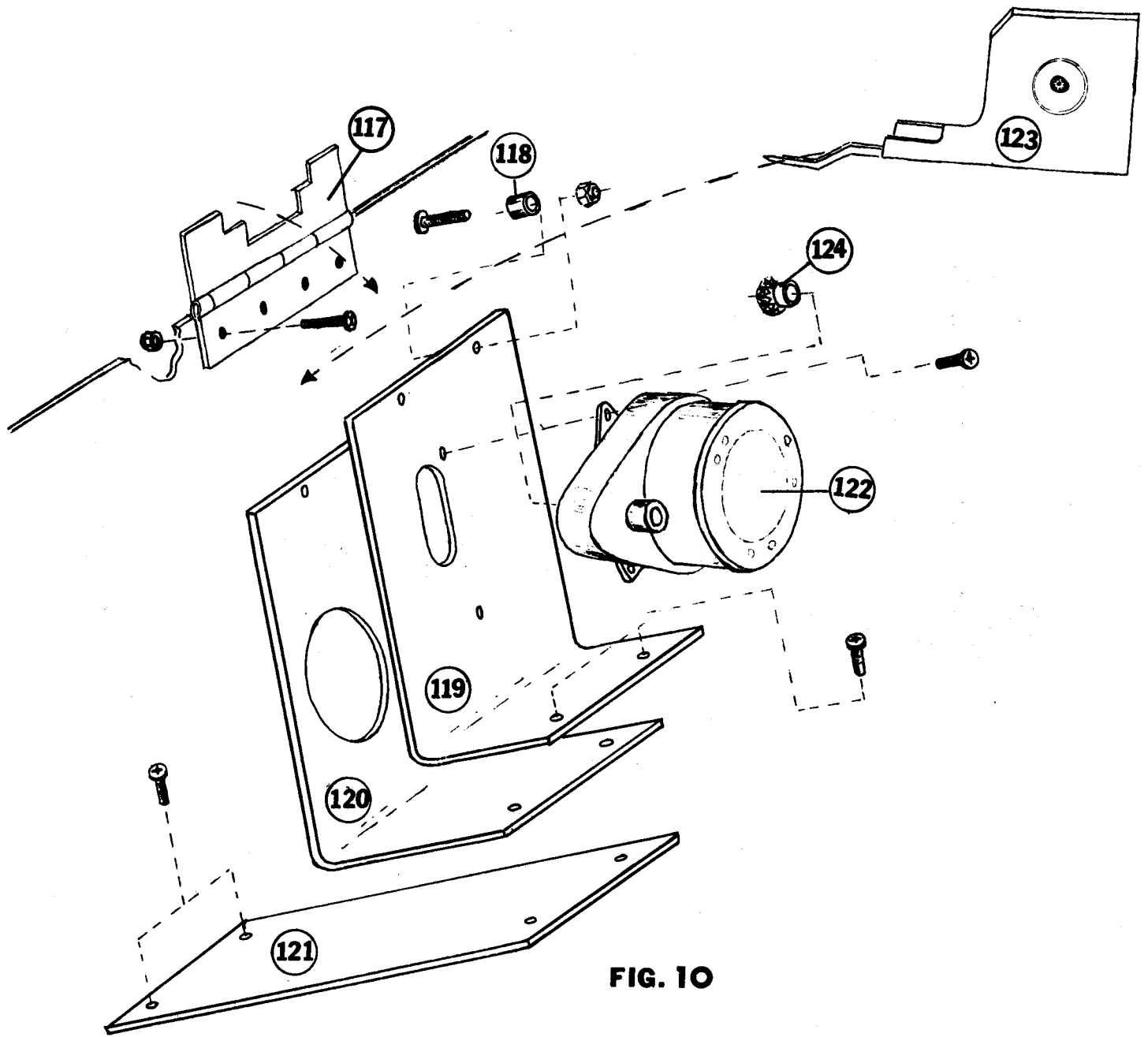


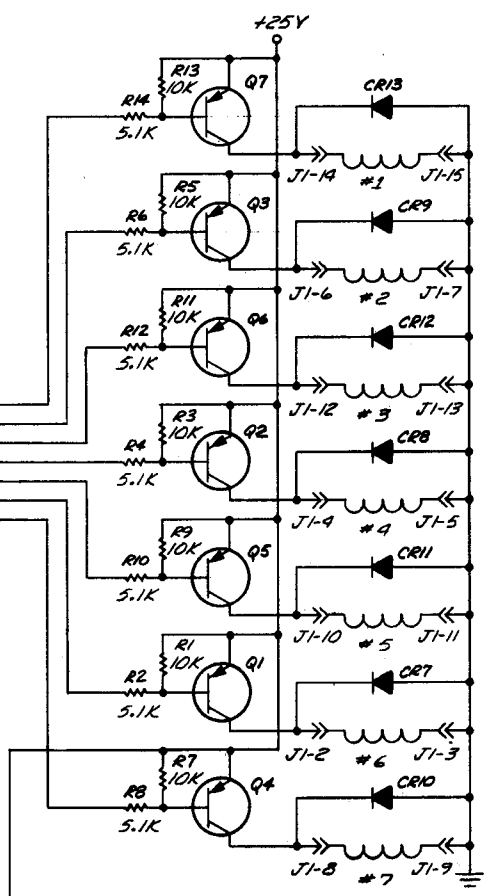
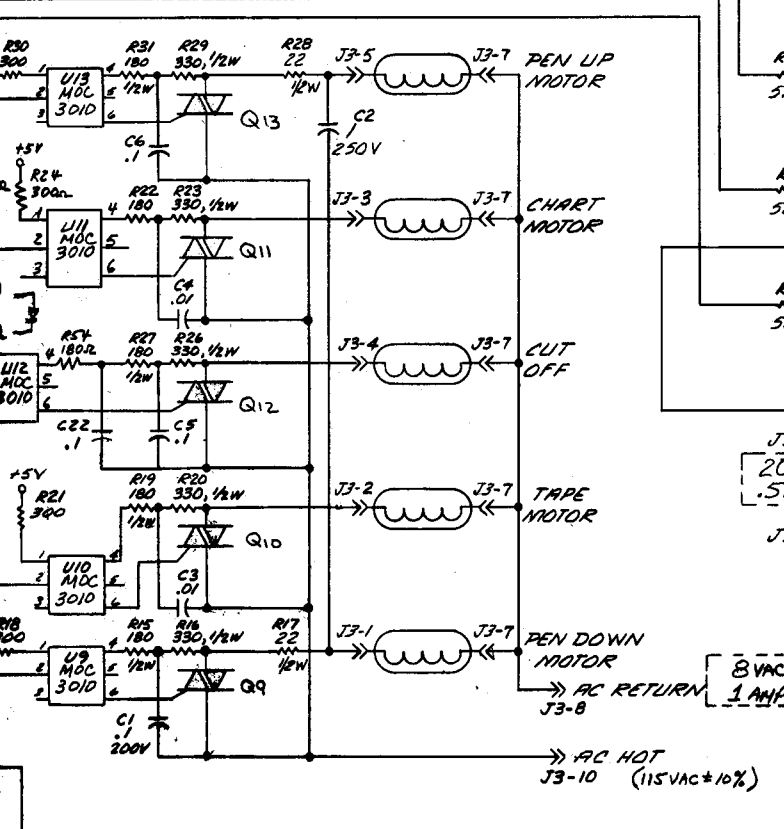
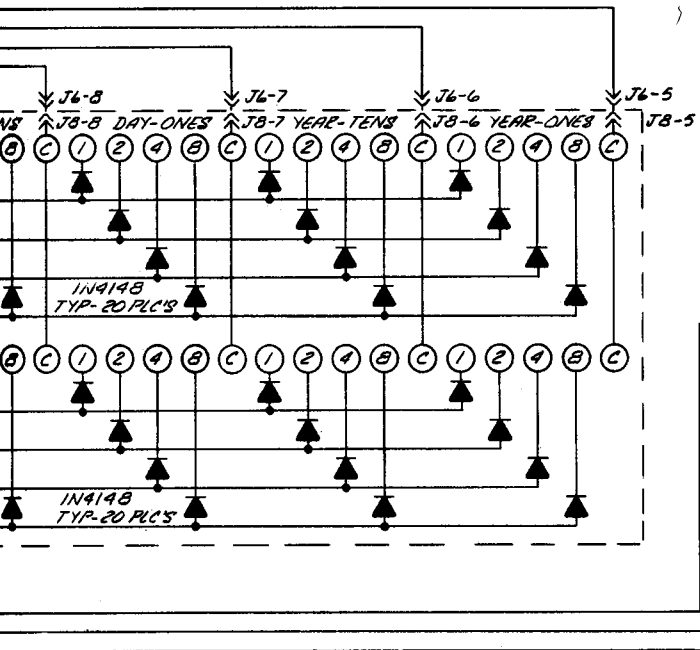
FIG. 10

## BIO-RHYTHM III CIRCUIT BOARD REPLACEMENT

---

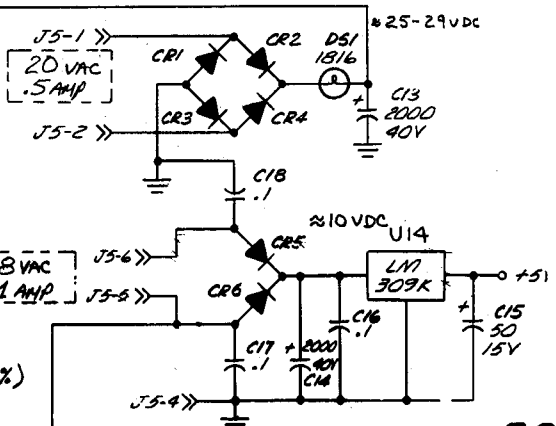
1. Unplug the machine
2. Carefully unplug each connector - DO NOT pull on the wires. Each connector is provided with a key to insure that it cannot be connected improperly. Take care not to damage the connectors, or plug them into the wrong location. Refer to Figure 6 for Harness lay-out.
3. Release the stand-off posts by squeezing the plastic lock inward.
4. Place the Circuit Board into a protective box.
5. Install the replacement board onto the stand-offs, and press into place. Each standoff should click to indicate proper installation.
6. Carefully install all connectors.
7. Double check the connectors using Figure 6 as a guide.
8. Apply power and test for proper operation.

(NOT ON BOARD)

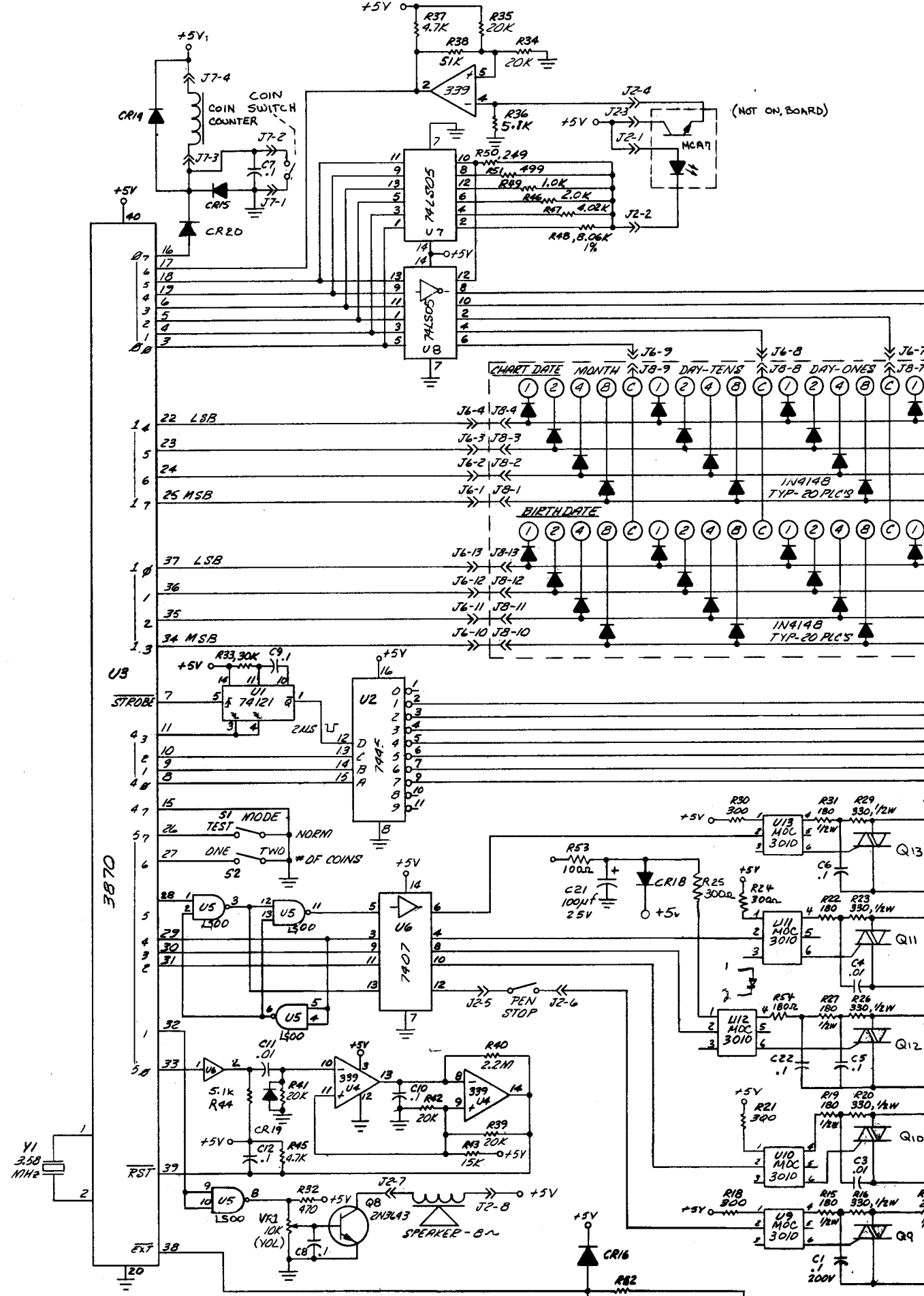


# 1 THRU #7  
PRINT HAMMERS

- LAST USED
- CR 18
  - C 22
  - R 54
  - U 14
  - Q 13
  - DS 1
  - VR 1
  - S 2



F8 SCHEMATIC



- 4. ALL TRANSISTORES ARE 2N6034.
- 3. ALL DIODES ARE 1N4002.
- 2. ALL CAPACITOR VALUES ARE IN MICROFARADS.
- 1. ALL RESISTOR VALUES ARE IN OHMS, 1/4W ±5%.

NOTE'S : UNLESS OTHERWISE SPECIFIED